

**GUARDRAIL TESTING PROGRAM IV  
VOLUME II: APPENDICES**

**U.S. Department of Transportation  
Federal Highway Administration**

**September 2004**

## **FOREWORD**

Please add foreword here. To be supplied by FHWA.

Michael F. Trentacoste  
Director, Office of Safety  
Research and Development

## **NOTICE**

This document is disseminated under the sponsorship of the U.S. Department of Transportation in the interest of information exchange. The U.S. Government assumes no liability for its contents or use thereof. This report does not constitute a standard, specification, or regulation.

The U.S. Government does not endorse products or manufacturers. Trade and manufacturer's names appear in this report only because they are considered essential to the object of the document.

1. Report No. FHWA-HRT-04-087		2. Government Accession No.		3. Recipient's Catalog No.	
4. Title and Subtitle Guardrail Testing Program IV Volume II: Appendices				5. Report Date September 2004	
				6. Performing Organization Code	
7. Author(s) D. Lance Bullard, Jr., Wanda L. Menges, C. Eugene Buth, and Rebecca R. Haug				8. Performing Organization Report No. 405181-F	
9. Performing Organization Name and Address Texas Transportation Institute The Texas A&M University System College Station, TX 77843-3135				10. Work Unit No. (TRAIS)	
				11. Contract or Grant No. DTFH71-99-C-00035	
12. Sponsoring Agency Name and Address Office of Safety and Traffic Operations Research and Development Federal Highway Administration 6300 Georgetown Pike McLean, VA 22101-2296				13. Type of Report and Period Covered Test Report September 1999-October 2003	
				14. Sponsoring Agency Code	
15. Supplementary Notes Research Study Title: Guardrail Testing Program IV Name of Contacting Officer's Technical Representative (COTR): Mr. Charles F. McDevitt (HRDS-4)					
16. Abstract <p>The Federal Highway Administration's (FHWA) objective for this contract was to crash test and evaluate several longitudinal barriers, bridge rails, and transitions used on Federal Lands Highways in accordance with National Cooperative Highway Research Program (NCHRP) <i>NCHRP Report 350</i> requirements. FHWA chose six longitudinal barriers, three bridge rails, and three transitions for evaluation under this contract. With regard to longitudinal barriers, the Rough Stone Masonry Guardwall and the Type A Steel-Backed Timber Guardrail were tested and evaluated according the <i>NCHRP Report 350</i> test level three (TL-3), the Steel-Backed Timber Round Log Rail and the Type B Steel-Backed Timber Guardrail were tested and evaluated according to test level two (TL-2), and the Glacier Removable Rail and the Glacier Round Log Removable Rail were tested and evaluated according to test level one (TL-1). The three bridge rails (the George Washington Memorial Parkway Bridge Rail, the Natchez Trace Bridge Rail, and the Tubular Steel-Backed Timber Bridge Rail) were evaluated according to TL-3. The transition from Type A Steel-Backed Timber Rail to Straight Stone Masonry Guardwall Parapet was tested and evaluated according to <i>NCHRP Report 350</i> test 2-21; the transition from Type A Steel-Backed Timber Rail to Straight Stone Masonry Guardwall Parapet with Tapered End and the Tubular Steel-Backed Timber Bridge Rail Transition were tested and evaluated according to <i>NCHRP Report 350</i> test 3-21.</p> <p>This report presents construction details of each device tested, results of <i>NCHRP Report 350</i> crash tests performed, and the evaluation each of the device's performance according to the guidelines of <i>NCHRP Report 350</i>.</p>					
17. Key Words Bridge rail, transition, guardrail, guardwall, longitudinal barrier, stone, masonry, timber rail, aesthetic, crash testing, roadside safety			18. Distribution Statement No restrictions. This document is available to the public through the National Technical Information Service, 5285 Port Royal Road, Springfield, VA 22161		
19. Security Classif. (of this report) Unclassified		20. Security Classif. (of this page) Unclassified		21. No. of Pages 636	22. Price

# SI\* (MODERN METRIC) CONVERSION FACTORS

## APPROXIMATE CONVERSIONS TO SI UNITS

Symbol	When You Know	Multiply By	To Find	Symbol
<b>LENGTH</b>				
in	inches	25.4	millimeters	mm
ft	feet	0.305	meters	m
yd	yards	0.914	meters	m
mi	miles	1.61	kilometers	km
<b>AREA</b>				
in <sup>2</sup>	square inches	645.2	square millimeters	mm <sup>2</sup>
ft <sup>2</sup>	square feet	0.093	square meters	m <sup>2</sup>
yd <sup>2</sup>	square yard	0.836	square meters	m <sup>2</sup>
ac	acres	0.405	hectares	ha
mi <sup>2</sup>	square miles	2.59	square kilometers	km <sup>2</sup>
<b>VOLUME</b>				
fl oz	fluid ounces	29.57	milliliters	mL
gal	gallons	3.785	liters	L
ft <sup>3</sup>	cubic feet	0.028	cubic meters	m <sup>3</sup>
yd <sup>3</sup>	cubic yards	0.765	cubic meters	m <sup>3</sup>
NOTE: volumes greater than 1000 L shall be shown in m <sup>3</sup>				
<b>MASS</b>				
oz	ounces	28.35	grams	g
lb	pounds	0.454	kilograms	kg
T	short tons (2000 lb)	0.907	megagrams (or "metric ton")	Mg (or "t")
<b>TEMPERATURE (exact degrees)</b>				
°F	Fahrenheit	5 (F-32)/9 or (F-32)/1.8	Celsius	°C
<b>ILLUMINATION</b>				
fc	foot-candles	10.76	lux	lx
fl	foot-Lamberts	3.426	candela/m <sup>2</sup>	cd/m <sup>2</sup>
<b>FORCE and PRESSURE or STRESS</b>				
lbf	poundforce	4.45	newtons	N
lbf/in <sup>2</sup>	poundforce per square inch	6.89	kilopascals	kPa

## APPROXIMATE CONVERSIONS FROM SI UNITS

Symbol	When You Know	Multiply By	To Find	Symbol
<b>LENGTH</b>				
mm	millimeters	0.039	inches	in
m	meters	3.28	feet	ft
m	meters	1.09	yards	yd
km	kilometers	0.621	miles	mi
<b>AREA</b>				
mm <sup>2</sup>	square millimeters	0.0016	square inches	in <sup>2</sup>
m <sup>2</sup>	square meters	10.764	square feet	ft <sup>2</sup>
m <sup>2</sup>	square meters	1.195	square yards	yd <sup>2</sup>
ha	hectares	2.47	acres	ac
km <sup>2</sup>	square kilometers	0.386	square miles	mi <sup>2</sup>
<b>VOLUME</b>				
mL	milliliters	0.034	fluid ounces	fl oz
L	liters	0.264	gallons	gal
m <sup>3</sup>	cubic meters	35.314	cubic feet	ft <sup>3</sup>
m <sup>3</sup>	cubic meters	1.307	cubic yards	yd <sup>3</sup>
<b>MASS</b>				
g	grams	0.035	ounces	oz
kg	kilograms	2.202	pounds	lb
Mg (or "t")	megagrams (or "metric ton")	1.103	short tons (2000 lb)	T
<b>TEMPERATURE (exact degrees)</b>				
°C	Celsius	1.8C+32	Fahrenheit	°F
<b>ILLUMINATION</b>				
lx	lux	0.0929	foot-candles	fc
cd/m <sup>2</sup>	candela/m <sup>2</sup>	0.2919	foot-Lamberts	fl
<b>FORCE and PRESSURE or STRESS</b>				
N	newtons	0.225	poundforce	lbf
kPa	kilopascals	0.145	poundforce per square inch	lbf/in <sup>2</sup>

\*SI is the symbol for the International System of Units. Appropriate rounding should be made to comply with Section 4 of ASTM E380.  
(Revised March 2003)

# TABLE OF CONTENTS

<b>INTRODUCTION</b> .....	1
<b>PROBLEM</b> .....	1
<b>BACKGROUND</b> .....	1
<b>OBJECTIVE</b> .....	1
<b>TEST PARAMETERS</b> .....	3
<b>TEST FACILITY</b> .....	3
<b>TEST ARTICLES</b> .....	3
<b>TEST CONDITIONS</b> .....	3
<b>EVALUATION CRITERIA</b> .....	3
<b>LONGITUDINAL BARRIERS</b> .....	5
<b>ROUGH STONE MASONRY GUARDWALL</b>	
<b>CRASH TEST 405181-1 (NCHRP REPORT 350 TEST NUMBER 3-11)</b> .....	5
<b>Target Test Conditions</b> .....	5
<b>Test Article—Design and Construction</b> .....	5
<b>Test Vehicle</b> .....	6
<b>Soil and Weather Conditions</b> .....	20
<b>Impact Description</b> .....	20
<b>Damage to Test Article</b> .....	21
<b>Vehicle Damage</b> .....	21
<b>Occupant Risk Factors</b> .....	21
<b>Assessment of Test Results</b> .....	26
<b>TYPE A STEEL-BACKED TIMBER GUARDRAIL</b>	
<b>CRASH TEST 405181-2 (NCHRP REPORT 350 TEST NUMBER 3-11)</b> .....	29
<b>Target Test Conditions</b> .....	29
<b>Test Article—Design and Construction</b> .....	29
<b>Test Vehicle</b> .....	30
<b>Soil and Weather Conditions</b> .....	30
<b>Impact Description</b> .....	37
<b>Damage to Test Article</b> .....	37
<b>Vehicle Damage</b> .....	37
<b>Occupant Risk Factors</b> .....	42
<b>Assessment of Test Results</b> .....	42
<b>STEEL-BACKED TIMBER ROUND LOG RAIL</b>	
<b>CRASH TEST 405181-4 (NCHRP REPORT 350 TEST NUMBER 2-10)</b> .....	45
<b>Target Test Conditions</b> .....	45
<b>Test Article—Design and Construction</b> .....	45
<b>Test Vehicle</b> .....	55
<b>Soil and Weather Conditions</b> .....	55

## TABLE OF CONTENTS (continued)

Impact Description .....	55
Damage to Test Article .....	58
Vehicle Damage .....	58
Occupant Risk Factors .....	58
Assessment of Test Results .....	58
<b>STEEL-BACKED TIMBER ROUND LOG RAIL</b>	
<b>CRASH TEST 405181-3 (NCHRP REPORT 350 TEST NUMBER 2-11) .....</b>	<b>67</b>
Target Test Conditions .....	67
Test Article—Design and Construction .....	67
Test Vehicle .....	67
Soil and Weather Conditions .....	67
Impact Description .....	71
Damage to Test Article .....	71
Vehicle Damage .....	71
Occupant Risk Factors .....	76
Assessment of Test Results .....	76
<b>TYPE B STEEL-BACKED TIMBER GUARDRAIL</b>	
<b>CRASH TEST 405181-13 (NCHRP REPORT 350 TEST NUMBER 2-11) .....</b>	<b>79</b>
Target Test Conditions .....	79
Test Article—Design and Construction .....	79
Test Vehicle .....	80
Soil and Weather Conditions .....	80
Impact Description .....	87
Damage to Test Article .....	87
Vehicle Damage .....	87
Occupant Risk Factors .....	92
Assessment of Test Results .....	92
<b>GLACIER REMOVABLE RAIL</b>	
<b>CRASH TEST 405181-14 (NCHRP REPORT 350 TEST NUMBER 1-10) .....</b>	<b>95</b>
Target Test Conditions .....	95
Test Article—Design and Construction .....	95
Test Vehicle .....	96
Soil and Weather Conditions .....	96
Impact Description .....	113
Damage to Test Article .....	113
Vehicle Damage .....	113
Occupant Risk Factors .....	118
Assessment of Test Results .....	118

## TABLE OF CONTENTS (continued)

<b>GLACIER REMOVABLE RAIL</b>	
<b>CRASH TEST 405181-15 (NCHRP REPORT 350 TEST NUMBER 1-11)</b> .....	121
<b>Target Test Conditions</b> .....	121
<b>Test Article—Design and Construction</b> .....	121
<b>Test Vehicle</b> .....	121
<b>Soil and Weather Conditions</b> .....	121
<b>Impact Description</b> .....	125
<b>Damage to Test Article</b> .....	125
<b>Vehicle Damage</b> .....	125
<b>Occupant Risk Factors</b> .....	130
<b>Assessment of Test Results</b> .....	130
<b>GLACIER ROUND LOG REMOVABLE RAIL</b>	
<b>CRASH TEST 405181-19 (NCHRP REPORT 350 TEST NUMBER 1-10)</b> .....	133
<b>Target Test Conditions</b> .....	133
<b>Test Article—Design and Construction</b> .....	133
<b>Test Vehicle</b> .....	134
<b>Soil and Weather Conditions</b> .....	134
<b>Impact Description</b> .....	151
<b>Damage to Test Article</b> .....	151
<b>Vehicle Damage</b> .....	151
<b>Occupant Risk Factors</b> .....	151
<b>Assessment of Test Results</b> .....	156
<b>GLACIER ROUND LOG REMOVABLE RAIL</b>	
<b>CRASH TEST 405181-20 (NCHRP REPORT 350 TEST NUMBER 1-11)</b> .....	159
<b>Target Test Conditions</b> .....	159
<b>Test Article—Design and Construction</b> .....	159
<b>Test Vehicle</b> .....	159
<b>Soil and Weather Conditions</b> .....	159
<b>Impact Description</b> .....	163
<b>Damage to Test Article</b> .....	163
<b>Vehicle Damage</b> .....	163
<b>Occupant Risk Factors</b> .....	168
<b>Assessment of Test Results</b> .....	168
<b>BRIDGE RAILS</b> .....	171
<b>GEORGE WASHINGTON MEMORIAL PARKWAY BRIDGE RAIL</b>	
<b>CRASH TEST 405181-9 (NCHRP REPORT 350 TEST NUMBER 3-11)</b> .....	171
<b>Target Test Conditions</b> .....	171
<b>Test Article—Design and Construction</b> .....	171
<b>Test Vehicle</b> .....	172

## TABLE OF CONTENTS (continued)

Weather Conditions .....	182
Impact Description .....	182
Damage to Test Article .....	182
Vehicle Damage .....	182
Occupant Risk Factors .....	187
Assessment of Test Results .....	187
<b>NATCHEZ TRACE BRIDGE RAIL</b>	
<b>CRASH TEST 405181-11 (NCHRP REPORT 350 TEST NUMBER 3-10) .....</b>	<b>191</b>
Target Test Conditions .....	191
Test Article—Design and Construction .....	191
Test Vehicle .....	192
Weather Conditions .....	192
Impact Description .....	200
Damage to Test Article .....	200
Vehicle Damage .....	200
Occupant Risk Factors .....	200
Assessment of Test Results .....	205
<b>NATCHEZ TRACE BRIDGE RAIL</b>	
<b>CRASH TEST 405181-12 (NCHRP REPORT 350 TEST NUMBER 3-11) .....</b>	<b>209</b>
Target Test Conditions .....	209
Test Article—Design and Construction .....	209
Test Vehicle .....	209
Weather Conditions .....	209
Impact Description .....	213
Damage to Test Article .....	213
Vehicle Damage .....	213
Occupant Risk Factors .....	218
Assessment of Test Results .....	218
<b>TUBULAR STEEL-BACKED TIMBER BRIDGE RAIL</b>	
<b>CRASH TEST 405181-21 (NCHRP REPORT 350 TEST NUMBER 3-11) .....</b>	<b>221</b>
Target Test Conditions .....	221
Test Article—Design and Construction .....	221
Test Vehicle .....	233
Weather Conditions .....	233
Impact Description .....	238
Damage to Test Article .....	238
Vehicle Damage .....	238
Occupant Risk Factors .....	243
Assessment of Test Results .....	243



## TABLE OF CONTENTS (continued)

<b>TRANSITIONS</b> .....	247
<b>TRANSITION FROM TYPE A STEEL-BACKED TIMBER RAIL TO STRAIGHT STONE MASONRY GUARDWALL PARAPET</b>	
<b>CRASH TEST 405181-5a (NCHRP REPORT 350 TEST NUMBER 2-21)</b> .....	247
<b>Target Test Conditions</b> .....	247
<b>Test Article—Design and Construction</b> .....	247
<b>Test Vehicle</b> .....	248
<b>Soil and Weather Conditions</b> .....	248
<b>Impact Description</b> .....	256
<b>Damage to Test Article</b> .....	256
<b>Vehicle Damage</b> .....	256
<b>Occupant Risk Factors</b> .....	261
<b>Rail Instrumentation Results</b> .....	261
<b>Assessment of Test Results</b> .....	261
<b>TRANSITION FROM TYPE A, STEEL-BACKED TIMBER RAIL TO STRAIGHT STONE MASONRY GUARDWALL PARAPET WITH TAPERED END</b>	
<b>CRASH TEST 405181-18 (NCHRP REPORT 350 TEST NUMBER 3-21)</b> .....	265
<b>Target Test Conditions</b> .....	265
<b>Test Article—Design and Construction</b> .....	265
<b>Test Vehicle</b> .....	266
<b>Soil and Weather Conditions</b> .....	266
<b>Impact Description</b> .....	283
<b>Damage to Test Article</b> .....	283
<b>Vehicle Damage</b> .....	283
<b>Occupant Risk Factors</b> .....	288
<b>Assessment of Test Results</b> .....	288
<b>TUBULAR STEEL-BACKED TIMBER BRIDGE RAIL TRANSITION</b>	
<b>CRASH TEST 405181-22 (NCHRP REPORT 350 TEST NUMBER 3-21)</b> .....	291
<b>Target Test Conditions</b> .....	291
<b>Test Article—Design and Construction</b> .....	291
<b>Test Vehicle</b> .....	303
<b>Soil and Weather Conditions</b> .....	308
<b>Impact Description</b> .....	308
<b>Damage to Test Article</b> .....	308
<b>Vehicle Damage</b> .....	311
<b>Occupant Risk Factors</b> .....	311
<b>Assessment of Test Results</b> .....	311

## TABLE OF CONTENTS (continued)

<b>SUMMARY AND CONCLUSIONS</b> .....	317
<b>LONGITUDINAL BARRIERS</b> .....	317
<b>Rough Stone Masonry Guardwall</b> .....	317
<b>Type A Steel-Backed Timber Guardrail</b> .....	317
<b>Steel-Backed Timber Round Log Rail</b> .....	320
<b>Type B Steel-Backed Timber Guardrail</b> .....	320
<b>Glacier Removable Rail</b> .....	320
<b>Glacier Round Log Removable Rail</b> .....	324
<b>BRIDGE RAILS</b> .....	329
<b>George Washington Memorial Parkway Bridge Rail</b> .....	329
<b>Natchez Trace Bridge Rail</b> .....	329
<b>Tubular Steel-Backed Timber Bridge Rail</b> .....	333
<b>TRANSITIONS</b> .....	333
<b>Transition from Type A Steel-Backed Timber Rail to Straight Stone</b> <b>Masonry Guardwall Parapet</b> .....	333
<b>Transition from Type A Steel-Backed Timber Rail to Straight Stone</b> <b>Masonry Guardwall Parapet with Tapered End</b> .....	336
<b>Tubular Steel-Backed Timber Bridge Rail Transition</b> .....	336
<b>CONCLUSIONS</b> .....	336
<b>REFERENCES</b> .....	341
<b>APPENDIX A. CRASH TEST PROCEDURES AND DATA ANALYSIS</b> .....	343
<b>ELECTRONIC INSTRUMENTATION AND DATA PROCESSING</b> <b>FOR THE TEST INSTALLATION</b> .....	343
<b>ELECTRONIC INSTRUMENTATION AND DATA PROCESSING</b> <b>FOR THE TEST VEHICLES</b> .....	345
<b>ANTHROPOMORPHIC DUMMY INSTRUMENTATION</b> .....	349
<b>PHOTOGRAPHIC INSTRUMENTATION AND DATA PROCESSING</b> .....	349
<b>TEST VEHICLE PROPULSION AND GUIDANCE</b> .....	350
<b>APPENDIX B. TEST VEHICLE PROPERTIES AND INFORMATION</b> .....	351
<b>APPENDIX C. SEQUENTIAL PHOTOGRAPHS</b> .....	399
<b>APPENDIX D. VEHICLE ANGULAR DISPLACEMENTS</b> <b>AND ACCELERATIONS</b> .....	447
<b>APPENDIX E. RAIL INSTRUMENTATION TRACES</b> .....	581

## LIST OF FIGURES

<u>Figure</u>		<u>Page</u>
1	Overall detail of the Rough Stone Masonry Guardwall .....	7
2	Reinforcement and anchor details of the Rough Stone Masonry Guardwall .....	14
3	Rough Stone Masonry Guardwall before testing .....	17
4	Vehicle/installation geometrics for test 405181-1 .....	18
5	Vehicle before test 405181-1 .....	19
6	Wind orientation .....	20
7	Vehicle trajectory path after test 405181-1 .....	22
8	Installation after test 405181-1 .....	23
9	Vehicle after test 405181-1 .....	24
10	Interior of vehicle for test 405181-1 .....	25
11	Details of the Type A Steel-Backed Timber Guardrail .....	31
12	Steel-Backed Timber Guardrail before testing .....	34
13	Vehicle/installation geometrics for test 405181-2 .....	35
14	Vehicle before test 405181-2 .....	36
15	Vehicle trajectory path after test 405181-2 .....	38
16	Installation after test 405181-2 .....	39
17	Vehicle after test 405181-2 .....	40
18	Interior of vehicle for test 405181-2 .....	41
19	Details of the Steel-Backed Timber Round Log Rail .....	46
20	Details of the timber block out for the Steel-Backed Timber Round Log Rail .....	50
21	Layout of test installation .....	53
22	Steel-Backed Timber Round Log Rail before testing .....	54
23	Vehicle/installation geometrics for test 405181-4 .....	56
24	Vehicle before test 405181-4 .....	57
25	Vehicle trajectory path after test 405181-4 .....	59
26	Installation after test 405181-4 .....	60
27	Vehicle after test 405181-4 .....	61
28	Interior of vehicle for test 405181-4 .....	62
29	Steel-Backed Timber Round Log Rail before test 405181-3 .....	68
30	Vehicle/installation geometrics for test 405181-3 .....	69
31	Vehicle before test 405181-3 .....	70
32	Vehicle trajectory path after test 405181-3 .....	72
33	Installation after test 405181-3 .....	73
34	Vehicle after test 405181-3 .....	74
35	Interior of vehicle for test 405181-3 .....	75
36	Details of the Type B Steel-Backed Timber Guardrail .....	81
37	Type B Steel-Backed Timber Guardrail before testing .....	84
38	Vehicle/installation geometrics for test 405181-13 .....	85
39	Vehicle before test 405181-13 .....	86
40	Vehicle trajectory path after test 405181-13 .....	88

## LIST OF FIGURES (continued)

<u>Figure</u>		<u>Page</u>
41	Installation after test 405181-13 .....	89
42	Vehicle after test 405181-13 .....	90
43	Interior of vehicle for test 405181-13 .....	91
44	Details of the Glacier Removable Rail – sheet 1 of 3 .....	97
45	Details of the Glacier Removable Rail – sheet 2 of 3 .....	101
46	Details of the Glacier Removable Rail – sheet 3 of 3 .....	105
47	Glacier Removable Rail before testing .....	110
48	Vehicle/installation geometrics for test 405181-14 .....	111
49	Vehicle before test 405181-14 .....	112
50	Vehicle trajectory path after test 405181-14 .....	114
51	Installation after test 405181-14 .....	115
52	Vehicle after test 405181-14 .....	116
53	Interior of vehicle for test 405181-14 .....	117
54	Glacier Removable Rail before testing .....	122
55	Vehicle/installation geometrics for test 405181-15 .....	123
56	Vehicle before test 405181-15 .....	124
57	Vehicle trajectory path after test 405181-15 .....	126
58	Installation after test 405181-15 .....	127
59	Vehicle after test 405181-15 .....	128
60	Interior of vehicle for test 405181-15 .....	129
61	Details of the Glacier Round Log Removable Rail – sheet 1 of 3 .....	135
62	Details of the Glacier Round Log Removable Rail – sheet 2 of 3 .....	139
63	Details of the Glacier Round Log Removable Rail – sheet 3 of 3 .....	143
64	Glacier Round Log Removable Rail before testing .....	148
65	Vehicle/installation geometrics for test 405181-19 .....	149
66	Vehicle before test 405181-19 .....	150
67	Vehicle trajectory path after test 405181-19 .....	152
68	Installation after test 405181-19 .....	153
69	Vehicle after test 405181-19 .....	154
70	Interior of vehicle for test 405181-19 .....	155
71	Glacier Round Log Removable Rail before test 405181-20 .....	160
72	Vehicle/installation geometrics for test 405181-20 .....	161
73	Vehicle before test 405181-20 .....	162
74	Vehicle trajectory path after test 405181-20 .....	164
75	Installation after test 405181-20 .....	165
76	Vehicle after test 405181-20 .....	166
77	Interior of vehicle for test 405181-20 .....	167
78	Details of the George Washington Memorial Parkway Bridge Rail – sheet 1 of 4 .	173
79	Details of the George Washington Memorial Parkway Bridge Rail – sheet 2 of 4 .	176
80	Details of the George Washington Memorial Parkway Bridge Rail – sheet 3 of 4 .	177
81	Details of the George Washington Memorial Parkway Bridge Rail – sheet 4 of 4 .	178

## LIST OF FIGURES (continued)

<u>Figure</u>		<u>Page</u>
82	George Washington Memorial Parkway Bridge Rail before testing .....	179
83	Vehicle/installation geometrics for test 405181-9 .....	180
84	Vehicle before test 405181-9 .....	181
85	Vehicle trajectory path after test 405181-9 .....	183
86	Installation after test 405181-9 .....	184
87	Vehicle after test 405181-9 .....	185
88	Interior of vehicle for test 405181-9 .....	186
89	Details of the Natchez Trace Bridge Rail .....	193
90	Layout of test installation .....	194
91	Natchez Trace Bridge Rail before test 405181-11 .....	197
92	Vehicle/installation geometrics for test 405181-11 .....	198
93	Vehicle before test 405181-11 .....	199
94	Vehicle trajectory path after test 405181-11 .....	201
95	Installation after test 405181-11 .....	202
96	Vehicle after test 405181-11 .....	203
97	Interior of vehicle for test 405181-11 .....	204
98	Natchez Trace Bridge Rail before testing .....	210
99	Vehicle/installation geometrics for test 405181-12 .....	211
100	Vehicle before test 405181-12 .....	212
101	Vehicle trajectory path after test 405181-12 .....	214
102	Installation after test 405181-12 .....	215
103	Vehicle after test 405181-12 .....	216
104	Interior of vehicle for test 405181-12 .....	217
105	Details of the Tubular Steel-Backed Timber Bridge Rail – sheet 1 of 3 .....	222
106	Details of the Tubular Steel-Backed Timber Bridge Rail – sheet 2 of 3 .....	226
107	Details of the Tubular Steel-Backed Timber Bridge Rail -- Transition Section -- sheet 3 of 3. ....	229
108	Details of the stem wall for the Tubular Steel-Backed Timber Bridge Rail Transition Section. ....	232
109	Layout of test installation .....	234
110	Tubular Steel-Backed Timber Bridge Rail before testing .....	235
111	Vehicle/installation geometrics for test 405181-21 .....	236
112	Vehicle before test 405181-21 .....	237
113	Vehicle trajectory path after test 405181-21 .....	239
114	Installation after test 405181-21 .....	240
115	Vehicle after test 405181-21 .....	241
116	Interior of vehicle for test 405181-21 .....	242
117	Details of the Steel-Backed Timber Rail Transition .....	249
118	Steel-Backed Timber Rail Transition before testing .....	253
119	Vehicle/installation geometrics for test 405181-5a .....	254

## LIST OF FIGURES (continued)

<u>Figure</u>		<u>Page</u>
120	Vehicle before test 405181-5a .....	255
121	Vehicle trajectory path after test 405181-5a .....	257
122	Installation after test 405181-5a .....	258
123	Vehicle after test 405181-5a .....	259
124	Interior of vehicle for test 405181-5a .....	260
125	Details of Steel-Backed Timber Transition to Straight Stone Masonry Guardwall with Tapered End – sheet M617-68A .....	267
126	Details of Steel-Backed Timber Transition to Straight Stone Masonry Guardwall with Tapered End – sheet M617-68B .....	271
127	Details of Steel-Backed Timber Transition to Straight Stone Masonry Guardwall with Tapered End – sheet M617-68C .....	275
128	Layout of installation .....	279
129	Steel-Backed Timber Transition to Straight Stone Masonry Guardwall with Tapered End before testing .....	280
130	Vehicle/installation geometrics for test 405181-18 .....	281
131	Vehicle before test 405181-18 .....	282
132	Vehicle trajectory path after test 405181-18 .....	284
133	Installation after test 405181-18 .....	285
134	Vehicle after test 405181-18 .....	286
135	Interior of vehicle for test 405181-18 .....	287
136	Details of the Tubular Steel-Backed Timber Bridge Rail .....	292
137	Details of the post assembly and splice detail for the Tubular Steel-Backed Timber Bridge Rail .....	296
138	Details of the Tubular Steel-Backed Timber Bridge Rail Transition Section. ....	299
139	Details of the stem wall for the Tubular Steel-Backed Timber Bridge Rail Transition Section. ....	302
140	Layout of test installation .....	304
141	Tubular Steel-Backed Timber Rail Transition before testing .....	305
142	Vehicle/installation geometrics for test 405181-22 .....	306
143	Vehicle before test 405181-22 .....	307
144	Vehicle trajectory path after test 405181-22 .....	309
145	Tubular Steel-Backed Rail Transition after test 405181-22 .....	310
146	Vehicle after test 405181-22 .....	312
147	Interior of vehicle for test 405181-22 .....	313
148	Strain gage installation on the Steel-Backed Timber Rail Transition for test 405181-5a .....	344
149	Vehicle properties for test 405181-2 .....	351
150	Occupant compartment measurements for test 405181-1 .....	353
151	Vehicle properties for test 405181-2 .....	354
152	Occupant compartment measurements for test 405181-2 .....	356
153	Vehicle properties for test 405181-4 .....	357

## LIST OF FIGURES (continued)

<u>Figure</u>		<u>Page</u>
154	Occupant compartment measurements for test 405181-4 .....	359
155	Vehicle properties for test 405181-3 .....	360
156	Occupant compartment measurements for test 405181-3 .....	362
157	Vehicle properties for test 405181-13 .....	363
158	Occupant compartment measurements for test 405181-13 .....	365
159	Vehicle properties for test 405181-14 .....	366
160	Occupant compartment measurements for test 405181-14 .....	368
161	Vehicle properties for test 405181-15 .....	369
162	Occupant compartment measurements for test 405181-15 .....	371
163	Vehicle properties for test 405181-19 .....	372
164	Occupant compartment measurements for test 405181-19 .....	374
165	Vehicle properties for test 405181-20 .....	375
166	Occupant compartment measurements for test 405181-20 .....	377
167	Vehicle properties for test 405181-9 .....	378
168	Occupant compartment measurements for test 405181-9 .....	380
169	Vehicle properties for test 405181-11 .....	381
170	Occupant compartment measurements for test 405181-11 .....	383
171	Vehicle properties for test 405181-12 .....	384
172	Occupant compartment measurements for test 405181-12 .....	386
173	Vehicle properties for test 405181-21 .....	387
174	Occupant compartment measurements for test 405181-21 .....	389
175	Vehicle properties for test 405181-5a .....	390
176	Occupant compartment measurements for test 405181-5a .....	392
177	Vehicle properties for test 405181-18 .....	393
178	Occupant compartment measurements for test 405181-18 .....	395
179	Vehicle properties for test 405181-22 .....	396
180	Occupant compartment measurements for test 405181-22 .....	398
181	Sequential photographs for test 405181-1 (overhead view) .....	399
182	Sequential photographs for test 405181-1 (rear view) .....	400
183	Sequential photographs for test 405181-2 (overhead view) .....	401
184	Sequential photographs for test 405181-2 (frontal view) .....	402
185	Sequential photographs for test 405181-2 (rear view) .....	403
186	Sequential photographs for test 405181-4 (overhead view) .....	404
187	Sequential photographs for test 405181-4 (frontal view) .....	405
188	Sequential photographs for test 405181-4 (rear view) .....	406
189	Sequential photographs for test 405181-3 (overhead view) .....	407
190	Sequential photographs for test 405181-3 (frontal view) .....	408
191	Sequential photographs for test 405181-3 (rear view) .....	409
192	Sequential photographs for test 405181-13 (overhead view) .....	410
193	Sequential photographs for test 405181-13 (frontal view) .....	411
194	Sequential photographs for test 405181-13 (rear view) .....	412

## LIST OF FIGURES (continued)

<u>Figure</u>		<u>Page</u>
195	Sequential photographs for test 405181-14 (overhead view) .....	413
196	Sequential photographs for test 405181-14 (frontal view) .....	414
197	Sequential photographs for test 405181-14 (rear view) .....	415
198	Sequential photographs for test 405181-15 (overhead view) .....	416
199	Sequential photographs for test 405181-15 (frontal view) .....	417
200	Sequential photographs for test 405181-15 (rear view) .....	418
201	Sequential photographs for test 405181-19 (overhead view) .....	419
202	Sequential photographs for test 405181-19 (frontal view) .....	420
203	Sequential photographs for test 405181-19 (rear view) .....	421
204	Sequential photographs for test 405181-20 (overhead view) .....	422
205	Sequential photographs for test 405181-20 (frontal view) .....	423
206	Sequential photographs for test 405181-20 (rear view) .....	424
207	Sequential photographs for test 405181-9 (overhead view) .....	425
208	Sequential photographs for test 405181-9 (frontal view) .....	426
209	Sequential photographs for test 405181-9 (rear view) .....	427
210	Sequential photographs for test 405181-11 (overhead view) .....	428
211	Sequential photographs for test 405181-11 (frontal view) .....	429
212	Sequential photographs for test 405181-11 (rear view) .....	430
213	Sequential photographs for test 405181-12 (overhead view) .....	431
214	Sequential photographs for test 405181-12 (frontal view) .....	432
215	Sequential photographs for test 405181-12 (rear view) .....	433
216	Sequential photographs for test 405181-21 (overhead view) .....	434
217	Sequential photographs for test 405181-21 (frontal view) .....	435
218	Sequential photographs for test 405181-21 (rear view) .....	436
219	Sequential photographs for test 405181-5a (overhead view) .....	437
220	Sequential photographs for test 405181-5a (frontal view) .....	438
221	Sequential photographs for test 405181-5a (rear view) .....	439
222	Sequential photographs for test 405181-18 (overhead view) .....	440
223	Sequential photographs for test 405181-18 (frontal view) .....	441
224	Sequential photographs for test 405181-18 (rear view) .....	442
225	Sequential photographs for test 405181-22 (overhead view) .....	443
226	Sequential photographs for test 405181-22 (frontal view) .....	444
227	Sequential photographs for test 405181-22 (rear view) .....	445
228	Vehicle coordinates .....	447
229	Vehicle angular displacements for test 405181-1 .....	448
230	Vehicle longitudinal accelerometer trace for test 405181-1 (accelerometer located at center of gravity) .....	449
231	Vehicle lateral accelerometer trace for test 405181-1 (accelerometer located at center of gravity) .....	450
232	Vehicle vertical accelerometer trace for test 405181-1 (accelerometer located at center of gravity) .....	451



## LIST OF FIGURES (continued)

<u>Figure</u>		<u>Page</u>
233	Vehicle longitudinal accelerometer trace for test 405181-1 (accelerometer located over rear axle) . . . . .	452
234	Vehicle lateral accelerometer trace for test 405181-1 (accelerometer located over rear axle) . . . . .	453
235	Vehicle vertical accelerometer trace for test 405181-1 (accelerometer located over rear axle) . . . . .	454
236	Vehicle angular displacements for test 405181-2 . . . . .	455
237	Vehicle longitudinal accelerometer trace for test 405181-2 (accelerometer located at center of gravity) . . . . .	456
238	Vehicle lateral accelerometer trace for test 405181-2 (accelerometer located at center of gravity) . . . . .	457
239	Vehicle vertical accelerometer trace for test 405181-2 (accelerometer located at center of gravity) . . . . .	458
240	Vehicle longitudinal accelerometer trace for test 405181-2 (accelerometer located over rear axle) . . . . .	459
241	Vehicle lateral accelerometer trace for test 405181-2 (accelerometer located over rear axle) . . . . .	460
242	Vehicle vertical accelerometer trace for test 405181-2 (accelerometer located over rear axle) . . . . .	461
243	Vehicle angular displacements for test 405181-4 . . . . .	462
244	Vehicle longitudinal accelerometer trace for test 405181-4 (accelerometer located at center of gravity) . . . . .	463
245	Vehicle lateral accelerometer trace for test 405181-4 (accelerometer located at center of gravity) . . . . .	464
246	Vehicle vertical accelerometer trace for test 405181-4 (accelerometer located at center of gravity) . . . . .	465
247	Vehicle longitudinal accelerometer trace for test 405181-4 (accelerometer located over rear axle) . . . . .	466
248	Vehicle lateral accelerometer trace for test 405181-4 (accelerometer located over rear axle) . . . . .	467
249	Vehicle vertical accelerometer trace for test 405181-4 (accelerometer located over rear axle) . . . . .	468
250	Vehicle longitudinal accelerometer trace for test 405181-4 (accelerometer located on top surface of instrument panel) . . . . .	469
251	Vehicle lateral accelerometer trace for test 405181-4 (accelerometer located on right front brake caliper) . . . . .	470
252	Vehicle longitudinal accelerometer trace for test 405181-4 (accelerometer located on left front brake caliper) . . . . .	471
253	Vehicle longitudinal accelerometer trace for test 405181-4 (accelerometer located on top of engine block) . . . . .	472

## LIST OF FIGURES (continued)

<u>Figure</u>		<u>Page</u>
254	Vehicle longitudinal accelerometer trace for test 405181-4 (accelerometer located on bottom of engine block) .....	473
255	Vehicle angular displacements for test 405181-3 .....	474
256	Vehicle longitudinal accelerometer trace for test 405181-3 (accelerometer located at center of gravity) .....	475
257	Vehicle lateral accelerometer trace for test 405181-3 (accelerometer located at center of gravity) .....	476
258	Vehicle vertical accelerometer trace for test 405181-3 (accelerometer located at center of gravity) .....	477
259	Vehicle longitudinal accelerometer trace for test 405181-3 (accelerometer located over rear axle) .....	478
260	Vehicle lateral accelerometer trace for test 405181-3 (accelerometer located over rear axle) .....	479
261	Vehicle vertical accelerometer trace for test 405181-3 (accelerometer located over rear axle) .....	480
262	Vehicle longitudinal accelerometer trace for test 405181-3 (accelerometer located on top surface of instrument panel) .....	481
263	Vehicle lateral accelerometer trace for test 405181-3 (accelerometer located on right front brake caliper) .....	482
264	Vehicle longitudinal accelerometer trace for test 405181-3 (accelerometer located on left front brake caliper) .....	483
265	Vehicle longitudinal accelerometer trace for test 405181-3 (accelerometer located on top of engine block) .....	484
266	Vehicle longitudinal accelerometer trace for test 405181-3 (accelerometer located on bottom of engine block) .....	485
267	Vehicle angular displacements for test 405181-13 .....	486
268	Vehicle longitudinal accelerometer trace for test 405181-13 (accelerometer located at center of gravity) .....	487
269	Vehicle lateral accelerometer trace for test 405181-13 (accelerometer located at center of gravity) .....	488
270	Vehicle vertical accelerometer trace for test 405181-13 (accelerometer located at center of gravity) .....	489
271	Vehicle longitudinal accelerometer trace for test 405181-13 (accelerometer located over rear axle) .....	490
272	Vehicle lateral accelerometer trace for test 405181-13 (accelerometer located over rear axle) .....	491
273	Vehicle vertical accelerometer trace for test 405181-13 (accelerometer located over rear axle) .....	492
274	Vehicle angular displacements for test 405181-14 .....	493
275	Vehicle longitudinal accelerometer trace for test 405181-14 (accelerometer located at center of gravity) .....	494

## LIST OF FIGURES (continued)

<u>Figure</u>		<u>Page</u>
276	Vehicle lateral accelerometer trace for test 405181-14 (accelerometer located at center of gravity) .....	495
277	Vehicle vertical accelerometer trace for test 405181-14 (accelerometer located at center of gravity) .....	496
278	Vehicle longitudinal accelerometer trace for test 405181-14 (accelerometer located over rear axle) .....	497
279	Vehicle lateral accelerometer trace for test 405181-14 (accelerometer located over rear axle) .....	498
280	Vehicle vertical accelerometer trace for test 405181-14 (accelerometer located over rear axle) .....	499
281	Vehicle longitudinal accelerometer trace for test 405181-14 (accelerometer located on top surface of instrument panel) .....	500
282	Vehicle lateral accelerometer trace for test 405181-14 (accelerometer located on right front brake caliper) .....	501
283	Vehicle longitudinal accelerometer trace for test 405181-14 (accelerometer located on left front brake caliper) .....	502
284	Vehicle longitudinal accelerometer trace for test 405181-14 (accelerometer located on top of engine block) .....	503
285	Vehicle longitudinal accelerometer trace for test 405181-14 (accelerometer located on bottom of engine block) .....	504
286	Vehicle angular displacements for test 405181-15 .....	505
287	Vehicle longitudinal accelerometer trace for test 405181-15 (accelerometer located at center of gravity) .....	506
288	Vehicle lateral accelerometer trace for test 405181-15 (accelerometer located at center of gravity) .....	507
289	Vehicle vertical accelerometer trace for test 405181-15 (accelerometer located at center of gravity) .....	508
290	Vehicle longitudinal accelerometer trace for test 405181-15 (accelerometer located over rear axle) .....	509
291	Vehicle lateral accelerometer trace for test 405181-15 (accelerometer located over rear axle) .....	510
292	Vehicle vertical accelerometer trace for test 405181-15 (accelerometer located over rear axle) .....	511
293	Vehicle angular displacements for test 405181-19 .....	512
294	Vehicle longitudinal accelerometer trace for test 405181-19 (accelerometer located at center of gravity) .....	513
295	Vehicle lateral accelerometer trace for test 405181-19 (accelerometer located at center of gravity) .....	514
296	Vehicle vertical accelerometer trace for test 405181-19 (accelerometer located at center of gravity) .....	515

## LIST OF FIGURES (continued)

<u>Figure</u>		<u>Page</u>
297	Vehicle longitudinal accelerometer trace for test 405181-19 (accelerometer located over rear axle) . . . . .	516
298	Vehicle lateral accelerometer trace for test 405181-19 (accelerometer located over rear axle) . . . . .	517
299	Vehicle vertical accelerometer trace for test 405181-19 (accelerometer located over rear axle) . . . . .	518
300	Vehicle angular displacements for test 405181-20 . . . . .	519
301	Vehicle longitudinal accelerometer trace for test 405181-20 (accelerometer located at center of gravity) . . . . .	520
302	Vehicle lateral accelerometer trace for test 405181-20 (accelerometer located at center of gravity) . . . . .	521
303	Vehicle vertical accelerometer trace for test 405181-20 (accelerometer located at center of gravity) . . . . .	522
304	Vehicle longitudinal accelerometer trace for test 405181-20 (accelerometer located over rear axle) . . . . .	523
305	Vehicle lateral accelerometer trace for test 405181-20 (accelerometer located over rear axle) . . . . .	524
306	Vehicle vertical accelerometer trace for test 405181-20 (accelerometer located over rear axle) . . . . .	525
307	Vehicle angular displacements for test 405181-9 . . . . .	526
308	Vehicle longitudinal accelerometer trace for test 405181-9 (accelerometer located at center of gravity) . . . . .	527
309	Vehicle lateral accelerometer trace for test 405181-9 (accelerometer located at center of gravity). . . . .	528
310	Vehicle vertical accelerometer trace for test 405181-9 (accelerometer located at center of gravity) . . . . .	529
311	Vehicle longitudinal accelerometer trace for test 405181-9 (accelerometer located over rear axle) . . . . .	530
312	Vehicle lateral accelerometer trace for test 405181-9 (accelerometer located over rear axle) . . . . .	531
313	Vehicle vertical accelerometer trace for test 405181-9 (accelerometer located over rear axle) . . . . .	532
314	Vehicle angular displacements for test 405181-11 . . . . .	533
315	Vehicle longitudinal accelerometer trace for test 405181-11 (accelerometer located at center of gravity) . . . . .	534
316	Vehicle lateral accelerometer trace for test 405181-11 (accelerometer located at center of gravity) . . . . .	535
317	Vehicle vertical accelerometer trace for test 405181-11 (accelerometer located at center of gravity) . . . . .	536

## LIST OF FIGURES (continued)

<u>Figure</u>		<u>Page</u>
318	Vehicle longitudinal accelerometer trace for test 405181-11 (accelerometer located over rear axle) . . . . .	537
319	Vehicle lateral accelerometer trace for test 405181-11 (accelerometer located over rear axle) . . . . .	538
320	Vehicle vertical accelerometer trace for test 405181-11 (accelerometer located over rear axle) . . . . .	539
321	Vehicle angular displacements for test 405181-12 . . . . .	540
322	Vehicle longitudinal accelerometer trace for test 405181-12 (accelerometer located at center of gravity) . . . . .	541
323	Vehicle lateral accelerometer trace for test 405181-12 (accelerometer located at center of gravity) . . . . .	542
324	Vehicle vertical accelerometer trace for test 405181-12 (accelerometer located at center of gravity) . . . . .	543
325	Vehicle longitudinal accelerometer trace for test 405181-12 (accelerometer located over rear axle) . . . . .	544
326	Vehicle lateral accelerometer trace for test 405181-12 (accelerometer located over rear axle) . . . . .	545
327	Vehicle vertical accelerometer trace for test 405181-12 (accelerometer located over rear axle) . . . . .	546
328	Vehicle angular displacements for test 405181-21 . . . . .	547
329	Vehicle longitudinal accelerometer trace for test 405181-21 (accelerometer located at center of gravity) . . . . .	548
330	Vehicle lateral accelerometer trace for test 405181-21 (accelerometer located at center of gravity) . . . . .	549
331	Vehicle vertical accelerometer trace for test 405181-21 (accelerometer located at center of gravity) . . . . .	550
332	Vehicle longitudinal accelerometer trace for test 405181-21 (accelerometer located over rear axle) . . . . .	551
333	Vehicle lateral accelerometer trace for test 405181-21 (accelerometer located over rear axle) . . . . .	552
334	Vehicle vertical accelerometer trace for test 405181-21 (accelerometer located over rear axle) . . . . .	553
335	Vehicle angular displacements for test 405181-5a . . . . .	554
336	Vehicle longitudinal accelerometer trace for test 405181-5a (accelerometer located at center of gravity) . . . . .	555
337	Vehicle lateral accelerometer trace for test 405181-5a (accelerometer located at center of gravity) . . . . .	556
338	Vehicle vertical accelerometer trace for test 405181-5a (accelerometer located at center of gravity) . . . . .	557

## LIST OF FIGURES (continued)

<u>Figure</u>		<u>Page</u>
339	Vehicle longitudinal accelerometer trace for test 405181-5a (accelerometer located over rear axle) . . . . .	558
340	Vehicle lateral accelerometer trace for test 405181-5a (accelerometer located over rear axle) . . . . .	559
341	Vehicle vertical accelerometer trace for test 405181-5a (accelerometer located over rear axle) . . . . .	560
342	Vehicle longitudinal accelerometer trace for test 405181-5a (accelerometer located on top surface of instrument panel) . . . . .	561
343	Vehicle longitudinal accelerometer trace for test 405181-5a (accelerometer located on right front brake caliper) . . . . .	562
344	Vehicle longitudinal accelerometer trace for test 405181-5a (accelerometer located on left front brake caliper) . . . . .	563
345	Vehicle longitudinal accelerometer trace for test 405181-5a (accelerometer located on top of engine block) . . . . .	564
346	Vehicle longitudinal accelerometer trace for test 405181-5a (accelerometer located on bottom of engine block) . . . . .	565
347	Vehicle angular displacements for test 405181-18 . . . . .	566
348	Vehicle longitudinal accelerometer trace for test 405181-18 (accelerometer located at center of gravity) . . . . .	567
349	Vehicle lateral accelerometer trace for test 405181-18 (accelerometer located at center of gravity) . . . . .	568
350	Vehicle vertical accelerometer trace for test 405181-18 (accelerometer located at center of gravity) . . . . .	569
351	Vehicle longitudinal accelerometer trace for test 405181-18 (accelerometer located over rear axle) . . . . .	570
352	Vehicle lateral accelerometer trace for test 405181-18 (accelerometer located over rear axle) . . . . .	571
353	Vehicle vertical accelerometer trace for test 405181-18 (accelerometer located over rear axle) . . . . .	572
354	Vehicle angular displacements for test 405181-22 . . . . .	573
355	Vehicle longitudinal accelerometer trace for test 405181-22 (accelerometer located at center of gravity) . . . . .	574
356	Vehicle lateral accelerometer trace for test 405181-22 (accelerometer located at center of gravity) . . . . .	575
357	Vehicle vertical accelerometer trace for test 405181-22 (accelerometer located at center of gravity) . . . . .	576
358	Vehicle longitudinal accelerometer trace for test 405181-22 (accelerometer located over rear axle) . . . . .	577
359	Vehicle lateral accelerometer trace for test 405181-22 (accelerometer located over rear axle) . . . . .	578

## LIST OF FIGURES (continued)

<u>Figure</u>		<u>Page</u>
360	Vehicle vertical accelerometer trace for test 405181-22 (accelerometer located over rear axle) . . . . .	579
361	Longitudinal accelerometer trace for test 405181-5a (accelerometer located at center of post 19) . . . . .	582
362	Axial strain, location 1, field side for test 405181-5a . . . . .	583
363	Axial strain, location 2, field side for test 405181-5a . . . . .	584
364	Axial strain, location 3, field side for test 405181-5a . . . . .	585
365	Axial strain, location 4, field side for test 405181-5a . . . . .	586
366	Axial strain, location 5, field side for test 405181-5a . . . . .	587
367	Axial strain, location 6, field side for test 405181-5a . . . . .	588

## LIST OF TABLES

<u>Table</u>	<u>Page</u>
1	Performance evaluation summary for the Rough Stone Masonry Guardwall, <i>NCHRP Report 350</i> test 3-11 ..... 318
2	Performance evaluation summary for the Type A Steel-Backed Timber Guardrail, <i>NCHRP Report 350</i> test 3-11 ..... 319
3	Performance evaluation summary for the Steel-Backed Timber Round Log Rail, <i>NCHRP Report 350</i> test 2-10 ..... 321
4	Performance evaluation summary for the Steel-Backed Timber Round Log Rail, <i>NCHRP Report 350</i> test 2-11 ..... 322
5	Performance evaluation summary for the Type B Steel-Backed Timber Guardrail, <i>NCHRP Report 350</i> test 2-11 ..... 323
6	Performance evaluation summary for the Glacier Removable Rail, <i>NCHRP Report 350</i> test 1-10 ..... 325
7	Performance evaluation summary for the Glacier Removable Rail, <i>NCHRP Report 350</i> test 1-11 ..... 326
8	Performance evaluation summary for the Glacier Round Log Removable Rail, <i>NCHRP Report 350</i> test 1-10 ..... 327
9	Performance evaluation summary for the Glacier Round Log Removable Rail, <i>NCHRP Report 350</i> test 1-11 ..... 328
10	Performance evaluation summary for the George Washington Memorial Parkway Bridge Rail, <i>NCHRP Report 350</i> test 3-11 ..... 330
11	Performance evaluation summary for the Natchez Trace Bridge Rail, <i>NCHRP Report 350</i> test 3-10 ..... 331
12	Performance evaluation summary for the Natchez Trace Bridge Rail, <i>NCHRP Report 350</i> test 3-11 ..... 332
13	Performance evaluation summary for the Tubular Steel-Backed Timber Bridge Rail, <i>NCHRP Report 350</i> test 3-11 ..... 334
14	Performance evaluation summary for the transition from Type A Steel-Backed Timber Rail to Straight Stone Masonry Guardwall Parapet, <i>NCHRP Report 350</i> test 2-21 ..... 335
15	Performance evaluation summary for the transition from Type A Steel-Backed Timber Rail to Straight Stone Masonry Guardwall Parapet with Tapered End, <i>NCHRP Report 350</i> test 3-21 ..... 337
16	Performance evaluation summary for the Tubular Steel-Backed Bridge Rail Transition, <i>NCHRP Report 350</i> test 3-21 ..... 338
17	Evaluation summary of testing performed ..... 339
18	Locations of vehicle accelerometers for test 405181-4 ..... 347
19	Locations of vehicle accelerometers for test 405181-3 ..... 347
20	Locations of vehicle accelerometers for test 405181-14 ..... 348
21	Locations of vehicle accelerometers for test 405181-5a ..... 348



## LIST OF TABLES

<u>Table</u>		<u>Page</u>
22	Exterior crush measurements for test 405181-1 .....	352
23	Exterior crush measurements for test 405181-2 .....	355
24	Exterior crush measurements for test 405181-4 .....	358
25	Exterior crush measurements for test 405181-3 .....	361
26	Exterior crush measurements for test 405181-13 .....	364
27	Exterior crush measurements for test 405181-14 .....	367
28	Exterior crush measurements for test 405181-15 .....	370
29	Exterior crush measurements for test 405181-19 .....	373
30	Exterior crush measurements for test 405181-20 .....	376
31	Exterior crush measurements for test 405181-9 .....	379
32	Exterior crush measurements for test 405181-11 .....	382
33	Exterior crush measurements for test 405181-12 .....	385
34	Exterior crush measurements for test 405181-21 .....	388
35	Exterior crush measurements for test 405181-5a .....	391
36	Exterior crush measurements for test 405181-18 .....	394
37	Exterior crush measurements for test 405181-22 .....	397



## **APPENDIX A. CRASH TEST PROCEDURES AND DATA ANALYSIS**

These crash test and data analysis procedures were in accordance with guidelines presented in National Cooperative Highway Research Program (NCHRP) *NCHRP Report 350*. Brief descriptions of these procedures are presented as follows.

### **ELECTRONIC INSTRUMENTATION AND DATA PROCESSING FOR THE TEST INSTALLATION**

For the test on the transition from Type A Steel-Backed Timber Rail to Straight Stone Masonry Guardwall Parapet, test 405181-5a, the transition was instrumented within the immediate area of impact. Six strain gages and one accelerometer were installed on the Steel-Backed Timber Rail transition to measure longitudinal strains in the steel rail and post acceleration during the crash test, as shown in figure 148. The tensile strains were reported as change of length per original length or microstrain, every 0.0001 seconds (s) during the impact along with the acceleration values in gravity ( $g$ 's).

A single active-arm, weldable, strain gage was installed on the surface of the 10 mm steel backing plate at each of the six locations of interest. Five of these locations were on the field side of the steel plate, which would produce strain in tension; one was on the traffic side, yielding results of compression during impact. The accelerometer was installed on the back of post 19 in the longitudinal axis of the rail. Strain gages were then connected, through cables, as quarter active-arm, full-bridge circuits using completion resistors in the amplifier units. This arrangement provided for measurement of surface strain, in the longitudinal direction, of the steel backing during the vehicle's impact.

Strain gage bridges were located as follows: 1) 5570 millimeters (mm) from the end of the parapet on the field side of the plate at 555 mm from ground level; 2) 2000 mm from the end of the parapet on the field side of the plate at 530 mm from ground level; 3) 1300 mm from the end of the parapet on the field side of the plate at 540 mm from ground level; 4) 960 mm from the end of the parapet on the field side of the plate at 540 mm from ground level; 5) 960 mm from the end of the parapet on the traffic side at 540 mm from ground level; 6) 70 mm from the end of the parapet on the field side of the plate at 550 mm from ground level. At these locations, the steel rail was prepared by first grinding away the mill scale to produce a clean and smooth surface in a 60 by 30 mm area where the gages were spot-welded to bond them to the steel.

Once wired and tested, each strain gage bridge was calibrated by placing a precision resistor across the gage to produce a microstrain value based on calculations using the published values included with each strain gage. The resulting values were then used to produce a microstrain calibration step at the amplifier when a precision resistor was switched across one leg of the bridge, which is referred to as an R-cal or shunt cal.

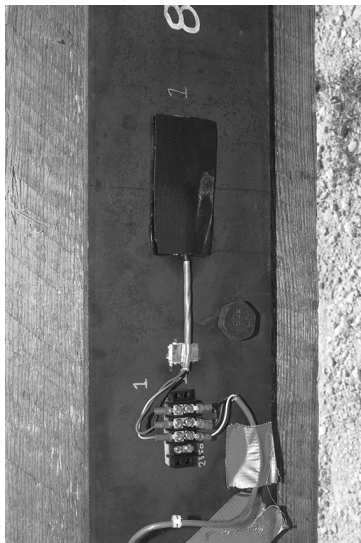

a) Strain gage #1.



b) Strain gage #2.

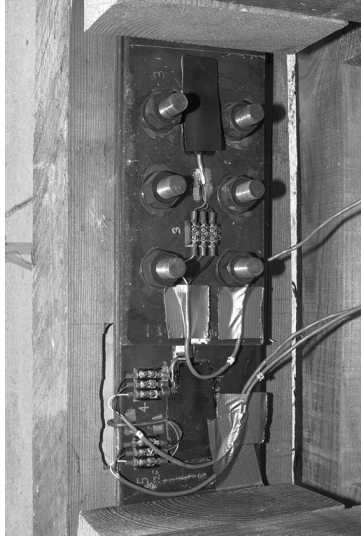

c) Strain gage #3, #4, and #5



d) Accelerometer on Post 19.

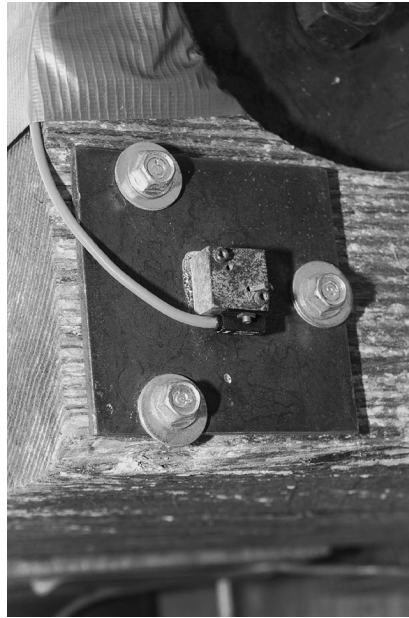

e) Close up of accelerometer on post 19.

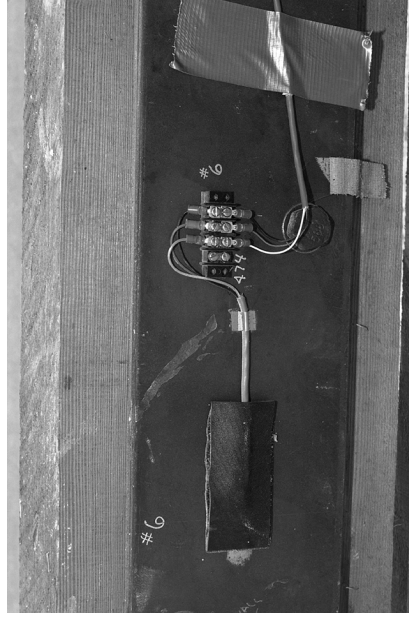

f) Strain gage #6.

Figure 148. Strain gage installation on the Type A Steel-Backed Timber Rail for test 405181-5a.

Approximately 100 meters (m) of cable connected the strain gages to the strain gage amplifiers; the amplifiers were located in a vehicle behind the installation with appropriate compensation calculations made for cable lengths. The output of the strain gage amplifiers fed a P-band telemetry transmitter in the instrumentation vehicle. Just before the impact, the R-cal data were sent over the telemetry link to provide subsequent correction values to the data. In the base station, these calibration and impact data signals were recorded simultaneously on a 28-track instrumentation tape recorder, with all of the vehicle data. These analog data were later digitized at 10,000 samples per second to produce force data in engineering units.

## **ELECTRONIC INSTRUMENTATION AND DATA PROCESSING FOR THE TEST VEHICLES**

The test vehicles were instrumented with three solid-state angular rate transducers to measure roll, pitch, and yaw rates; a triaxial accelerometer near the vehicle's center of gravity (c.g.) to measure longitudinal, lateral, and vertical acceleration levels; and a backup biaxial accelerometer in the rear of the vehicle to measure longitudinal and lateral acceleration levels. These accelerometers were ENDEVCO® Model 2262CA, piezoresistive accelerometers with a  $\pm 100$  g range.

The accelerometers are strain gage type with a linear millivolt output proportional to acceleration. Angular rate transducers are solid-state, gas flow units designed for high-g service. Signal conditioners and amplifiers in the test vehicle increase the low-level signals to a  $\pm 2.5$  volt maximum level. The signal conditioners also provide the capability of an R-Cal or shunt calibration for the accelerometers and a precision voltage calibration for the rate transducers. The electronic signals from the accelerometers and rate transducers are transmitted to a base station by means of a 15-channel, constant bandwidth, Inter-Range Instrumentation Group (IRIG), FM/FM telemetry link for recording on magnetic tape and for display on a real-time strip chart. Calibration signals from the test vehicle are recorded before the test and immediately afterward. A crystal-controlled time reference signal is simultaneously recorded with the data. Pressure-sensitive switches on the bumper of the impacting vehicle are actuated before impact by wooden dowels to indicate the elapsed time over a known distance to provide a measurement of impact velocity. The initial contact also produces an "event" mark on the data record to establish the instant of contact with the installation.

The multiplex of data channels, transmitted on one radio frequency, is received and demultiplexed onto separate tracks of a the 28-track tape recorder. After the test, the data are played back from the tape machine, digitized, and filtered with Society of Automotive Engineers (SAE) (SAE J211) filters, using a microcomputer, at 10,000 samples per second per channel, for analysis and evaluation of impact performance.

All accelerometers are calibrated annually according to SAE J211 4.6.1 by means of an ENDEVCO® 2901 precision primary vibration standard. This device and its support instruments are returned to the factory annually for a National Institute of Standards and Technology (NIST) traceable calibration. The subsystems of each data channel are also

evaluated annually using instruments with current NIST traceability, and the results factored into the accuracy of the total data channel according to SAE J211. Calibrations and evaluations are made any time data are suspect.

The Test Risk Assessment Program (TRAP) uses the data from vehicle-mounted linear accelerometers to compute occupant/compartiment impact velocities, time of occupant/compartiment impact after vehicle impact, and the highest 10-milliseconds (ms) average ridedown acceleration. TRAP calculates a vehicle impact velocity and the change in vehicle velocity at the end of a given impulse period. In addition, maximum average accelerations over 50-ms intervals in each of the three directions are computed. For reporting purposes, the data from the vehicle-mounted accelerometers are filtered with a 60-Hertz (Hz) digital filter and acceleration-versus-time curves for the longitudinal, lateral, and vertical directions are plotted using TRAP.

TRAP uses the data from the yaw, pitch, and roll rate transducers to compute angular displacement in degrees at 0.0001-s intervals and then plots: yaw, pitch, and roll versus time. These displacements are in reference to the vehicle-fixed coordinate system with the initial position and orientation of the vehicle-fixed coordinate system being initial impact.

In addition, for the tests on the two tests on the Steel-Backed Timber Round Log (405181-4 and 3), the small car test on the Glacier Removable Rail (405181-14), and the transition from Type A Steel-Backed Timber Rail to Straight Stone Masonry Guardwall Parapet (405181-5a), there were extra accelerometers on the vehicles. The test vehicles in these particular tests were instrumented with five uniaxial accelerometers mounted in the following locations: 1) center top surface of the instrument panel; 2) inside end of right front wheel spindle; 3) inside end of left front wheel spindle; 4) top of engine block; and 5) bottom of engine block. The location of each accelerometer is reported in tables 18 through 21. These accelerometers were ENDEVCO® Model 7264A low-mass piezoresistive accelerometers with a  $\pm 2000$  g range.

Onboard data acquisition is provided by Tiny Data Acquisition System Professional (TDAS PRO) hardware, which is self-contained and designed to withstand the accelerations commonly experienced in onboard, crash-testing applications. Each TDAS module/system functions as a complete data recorder with integral microprocessor control, adaptive signal conditioning, excitation sources, analog-to-digital (A/D) circuitry, data memory, and battery pack.

TDAS PRO functions are set up by an IBM®-compatible computer running TDAS PRO software. After the computer initializes the system, it can be disconnected and the modules will collect data with no additional support. After the test, data stored in each module are downloaded to the personal computer (PC) hard drive in binary format. Once on the hard drive, the binary data files are then unpacked for viewing and post-processing.

Table 18. Locations of vehicle accelerometers for test 405181-4.

<b>Location</b>	<b>X (mm) (distance from front axle)*</b>	<b>Y (mm) (distance from centerline)*</b>	<b>Z (mm) (distance from ground)*</b>	<b>Data Axis</b>
Instrument panel	-620	0	-880	+X
Right front wheel spindle	+50	-650	-210	-Y
Left front wheel spindle	+50	+650	-210	+X
Top of engine block	+325	+50	-740	+X
Bottom of engine block	+220	+270	-200	+X
Vehicle c.g.	-945	0	-350	+X,+Y,+Z
Vehicle rear axle	-2425	-120	-510	+X,+Y,+Z

\*Reference point: X = 0 at front axle      Y = 0 at centerline      Z = 0 at ground  
 Sign convention: +X = forward              +Y = right              +Z = down

Table 19. Locations of vehicle accelerometers for test 405181-3.

<b>Location</b>	<b>X (mm) (distance from front axle)*</b>	<b>Y (mm) (distance from centerline)*</b>	<b>Z (mm) (distance from ground)*</b>	<b>Data Axis</b>
Instrument panel	-830	0	-1330	+X
Right front wheel spindle	0	-775	-360	+X
Left front wheel spindle	0	+775	-360	+Y
Top of engine block	+230	+80	-940	+X
Bottom of engine block	-310	+140	-380	+X
Vehicle c.g.	-1480	0	-650	+X,+Y,+Z
Vehicle rear axle	-3360	0	-910	+X,+Y,+Z

\*Reference point: X = 0 at front axle      Y = 0 at centerline      Z = 0 at ground  
 Sign convention: +X = forward              +Y = right              +Z = down

Table 20. Locations of vehicle accelerometers for test 405181-14.

Location	X (mm) (distance from front axle)	Y (mm) (distance from centerline)	Z (mm) (distance from ground)	Data Axis
Instrument panel	-600	0	-930	+X
Right front wheel spindle	0	+670	-240	+X
Left front wheel spindle	0	-670	-240	+Y
Top of engine block	+194	+183	-731	+X
Bottom of engine block	+240	-40	-220	+X
Vehicle c.g.	-940	0	-400	+X,+Y,+Z
Vehicle rear axle	-2500	-100	-580	+X,+Y,+Z

\*Reference point: X = 0 at front axle Y = 0 at centerline Z = 0 at ground  
 Sign convention: +X = forward +Y = right +Z = down

Table 21. Locations of vehicle accelerometers for test 405181-5a.

Location	X (mm) (distance from front axle)	Y (mm) (distance from centerline)	Z (mm) (distance from ground)	Data Axis
Instrument panel	-940	0	-1360	+X
Right front wheel spindle	0	+710	-340	+X
Left front wheel spindle	0	-710	-340	+Y
Top of engine block	+90	-80	-890	+X
Bottom of engine block	-355	0	-310	+X
Vehicle c.g.	-1450	0	-670	+X,+Y,+Z
Vehicle rear axle	-3360	0	-830	+X,+Y,+Z

\*Reference point: X = 0 at front axle Y = 0 at centerline Z = 0 at ground  
 Sign convention: +X = forward +Y = right +Z = down



The TDAS PRO system is rated for and tested to greater than 100 g's, 0.012 s duration in all axes. The nominal sensor input voltage range is  $\pm 5.0$  volts at a gain of 1. Voltages up to  $\pm 6.25$  volts may be recorded when channel gain is set to 0.8. Each TDAS PRO module contains seven 0.1 percent internal shunt calibration resistors. The TDAS PRO modules contain a shunt emulation circuit that applies the output of a 16-bit digital-to-analog converter (DAC) to connected bridges via a precision resistor when "Emulation" is chosen as the shunt calibration method. DAC settings are automatically calculated by the software to simulate 100 percent of the requested full-scale at approximately 80 percent of the full-scale of the A/D converter.

TDAS PRO modules contain eight-pole Butterworth anti-aliasing filters with a fixed -3 decibel (dB) knee point at 4300 Hz. Each channel also has a software-controlled, variable five-pole Butterworth filter for sampling rates below 12,500 samples per second per channel. The TDAS PRO software automatically chooses the best filter setting for a sampling rate. The sensor channel set-up screen allows one to select SAE-channel-class software filters for post-processing. The software filter is a four-pole phaseless Butterworth algorithm that complies with SAE J211 requirements. A custom -3 dB software filter knee may also be applied, and no software filter can also be used.

Raw data collected with the TDAS PRO system are stored in binary format. All plotting and viewing routines apply any selected software filtering on the fly. Filtered data files can be output in American Standard Code for Information Interchange (ASCII) or DIAdem format.

## **ANTHROPOMORPHIC DUMMY INSTRUMENTATION**

A Hybrid II, 50th percentile male anthropomorphic dummy, restrained with lap and shoulder belts, was placed in the driver's position of the vehicle. The dummy was uninstrumented.

## **PHOTOGRAPHIC INSTRUMENTATION AND DATA PROCESSING**

Photographic coverage of the test included three high-speed cameras: one overhead with a field of view perpendicular to the ground and directly over the impact point; one placed behind the installation at an angle; and a third placed to have a field of view parallel to and aligned with the installation at the downstream end. A flash bulb activated by pressure-sensitive tape switches was positioned on the impacting vehicle to indicate the instant of contact with the installation and was visible from each camera. The films from these high-speed cameras were analyzed on a computer-linked motion analyzer to observe phenomena occurring during the collision and to obtain event time, displacement, and angular data. A 16-mm movie cine, a BETACAM™, a VHS-format video camera, and still cameras were used to document conditions of the test vehicle and installation before and after the test.

## **TEST VEHICLE PROPULSION AND GUIDANCE**

The test vehicle was towed into the test installation using a steel cable guidance and reverse tow system. A steel cable for guiding the test vehicle was tensioned along the path, anchored at each end, and threaded through an attachment to the front wheel of the test vehicle. An additional steel cable was connected to the test vehicle, passed around a pulley near the impact point, through a pulley on the tow vehicle, and then anchored to the ground so the tow vehicle moved away from the test site. A two-to-one speed ratio between the test and tow vehicle existed with this system. Just before impact with the installation, the test vehicle was released to be freewheeling and unrestrained. The vehicle remained freewheeling (i.e., no steering or braking inputs) until it cleared the immediate test site area, at which time brakes on the vehicle were activated bringing it to a safe and controlled stop.

# APPENDIX B. TEST VEHICLE PROPERTIES AND INFORMATION

DATE: 06/29/00 TEST NO.: 405181-1 VIN NO.: 1GTFC24TXXE538350  
 YEAR: 1999 MAKE: Chevrolet MODEL: 2500 Pickup Truck  
 TIRE INFLATION PRESSURE: \_\_\_\_\_ ODOMETER: 000823 TIRE SIZE: LT 225 75R16

MASS DISTRIBUTION (kg) LF 599 RF 562 LR 419 RR 420

DESCRIBE ANY DAMAGE TO VEHICLE PRIOR TO TEST:  
 \_\_\_\_\_

● Denotes accelerometer location.  
 NOTES: R-80 mm ToLT

ENGINE TYPE: 8 CYL  
 ENGINE CID: 5.3L  
 TRANSMISSION TYPE:  
 AUTO  
 MANUAL  
 OPTIONAL EQUIPMENT:  
 \_\_\_\_\_  
 \_\_\_\_\_  
 \_\_\_\_\_

DUMMY DATA:  
 TYPE: 50th percentile male  
 MASS: 76 kg  
 SEAT POSITION: Driver

GEOMETRY - (mm)

A	<u>1820</u>	E	<u>1340</u>	J	<u>1090</u>	N	<u>1670</u>	R	<u>730</u>
B	<u>840</u>	F	<u>5560</u>	K	<u>715</u>	O	<u>1680</u>	S	<u>890</u>
C	<u>3380</u>	G	<u>1417.9</u>	L	<u>80</u>	P	<u>740</u>	T	<u>1440</u>
D	<u>1865</u>	H	<u>-----</u>	M	<u>425</u>	Q	<u>440</u>	U	<u>3330</u>

MASS - (kg)	CURB	TEST INERTIAL	GROSS STATIC
M <sub>1</sub>	<u>1273</u>	<u>1161</u>	<u>1202</u>
M <sub>2</sub>	<u>862</u>	<u>839</u>	<u>879</u>
M <sub>T</sub>	<u>2135</u>	<u>2000</u>	<u>2076</u>

Figure 149. Vehicle properties for test 405181-1.

Table 22. Exterior crush measurements for test 405181-1.

VEHICLE CRUSH MEASUREMENT SHEET<sup>1</sup>

Complete When Applicable	
End Damage	Side Damage
Undeformed end width _____  Corner shift: A1 _____ A2 _____  End shift at frame Collision Damage Classification (CDC) (check one) < 102 mm _____ ≥ 102 mm _____	Bowing: B1 _____ X1 _____  B2 _____ X2 _____   Bowing constant  $\frac{X1 + X2}{2} = \underline{\hspace{2cm}}$

Note: Measure C1 to C6 from driver to passenger side in front or rear impacts—rear to front in side impacts.  
All measurements in millimeters.

Specific Impact Number	Plane* of C Measurements	Direct Damage		Field L**	C <sub>1</sub>	C <sub>2</sub>	C <sub>3</sub>	C <sub>4</sub>	C <sub>5</sub>	C <sub>6</sub>	±D
		Width ** (CDC)	Max*** Crush								
1	At front bumper	1050	550	1510	+50	-30	-85	-190	-380	-550	0
2	Along right side – 700 mm above ground	1050	540	1140	-140	-210	N/A	N/A	-415	-540	+1490

<sup>1</sup>Table taken from National Accident Sampling System (NASS).

\*Identify the plane at which the C measurements are taken (e.g., at bumper, above bumper, at sill, above sill, at beltline, etc.) or label adjustments (e.g., free space).

Free space value is defined as the distance between the baseline and the original body contour taken at the individual C locations. This may include the following: bumper lead, bumper taper, side protrusion, side taper, etc. Record the value for each C measurement and maximum crush.

\*\*Measure and document on the vehicle diagram the beginning or end of the direct damage width and field L (e.g., side damage with respect to undamaged axle).

\*\*\*Measure and document on the vehicle diagram the location of the maximum crush.

Note: Use as many lines/columns as necessary to describe each damage profile.

# Truck

## Occupant Compartment Deformation

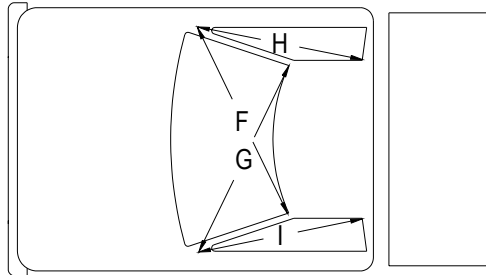

a) Top view of deformation zones.

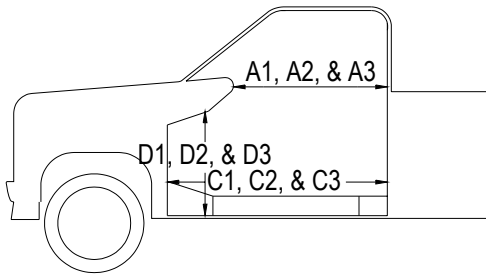

b) Side view of deformation zones.

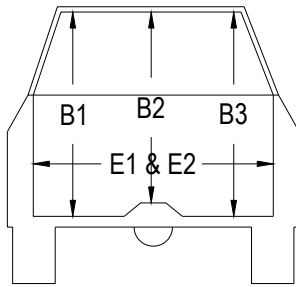

c) End view of deformation zones.

	BEFORE (mm)	AFTER (mm)
A1	965	965
A2	941	924
A3	945	890
B1	1108	1108
B2	1061	1071
B3	1111	1091
C1	1375	1375
C2	1372	1351
C3	1400	1275
D1	330	330
D2	162	186
D3	307	410
E1	1597	1625
E2	1592	1630
F	1470	1480
G	1470	1470
H	1000	970
I	1000	1000
J*	1531	1425

\*J = Lateral measurement across cab floor from kickpanel to kickpanel.

Figure 150. Occupant compartment measurements for test 405181-1.

DATE: 12-11-00 TEST NO.: 405181-2 VIN NO.: 1GCGC24M2TZ126015  
 YEAR: 1996 MAKE: Chevrolet MODEL: 2500 Pickup Truck  
 TIRE INFLATION PRESSURE: \_\_\_\_\_ ODOMETER: 213073 TIRE SIZE: LT 245 75R16

MASS DISTRIBUTION (kg) LF 568 RF 528 LR 471 RR 433

DESCRIBE ANY DAMAGE TO VEHICLE PRIOR TO TEST:

---

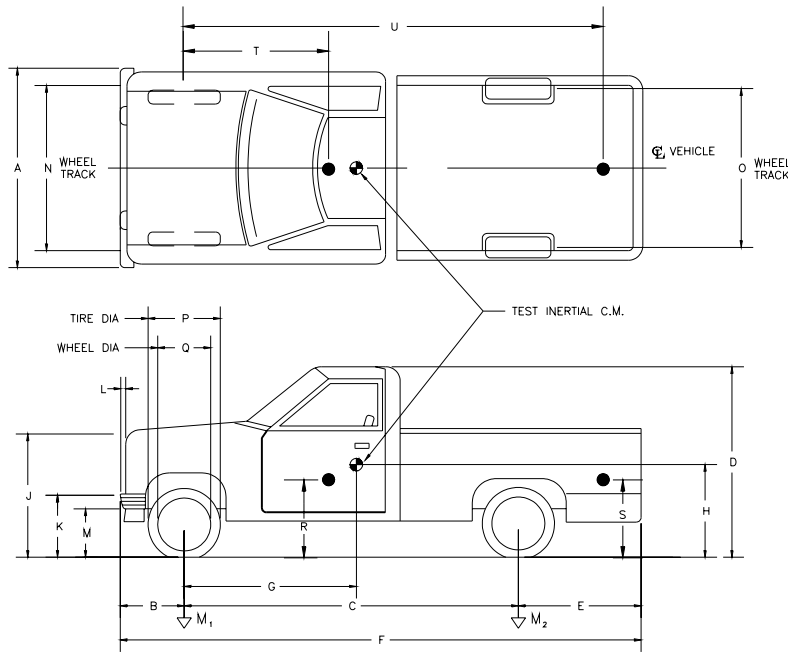

● Denotes accelerometer location.

NOTES: \_\_\_\_\_  
 \_\_\_\_\_  
 \_\_\_\_\_

ENGINE TYPE: 8 CYL

ENGINE CID: 5.7L

TRANSMISSION TYPE:

AUTO  
 MANUAL

OPTIONAL EQUIPMENT:

6 LUGS

DUMMY DATA:

TYPE: 50th percentile male

MASS: 75 kg

SEAT POSITION: Driver

GEOMETRY - (mm)

A	<u>1890</u>	E	<u>1310</u>	J	<u>1040</u>	N	<u>1595</u>	R	<u>645</u>
B	<u>840</u>	F	<u>5500</u>	K	<u>600</u>	O	<u>1620</u>	S	<u>860</u>
C	<u>3350</u>	G	<u>1514.2</u>	L	<u>75</u>	P	<u>730</u>	T	<u>1450</u>
D	<u>1810</u>	H	<u>---</u>	M	<u>395</u>	Q	<u>445</u>	U	<u>3350</u>

MASS - (kg)	CURB	TEST INERTIAL	GROSS STATIC
M <sub>1</sub>	<u>1131</u>	<u>1096</u>	<u>1140</u>
M <sub>2</sub>	<u>768</u>	<u>904</u>	<u>935</u>
M <sub>T</sub>	<u>1899</u>	<u>2000</u>	<u>2075</u>

Figure 151. Vehicle properties for test 405181-2.

Table 23. Exterior crush measurements for test 405181-2.

VEHICLE CRUSH MEASUREMENT SHEET<sup>1</sup>

Complete When Applicable	
End Damage	Side Damage
Undeformed end width _____  Corner shift: A1 _____ A2 _____  End shift at frame (CDC) (check one) < 102 mm _____ ≥ 102 mm _____	Bowing: B1 ____ X1 ____  B2 ____ X2 ____   Bowing constant  $\frac{X1 + X2}{2} = \underline{\hspace{2cm}}$

Note: Measure C1 to C6 from driver to passenger side in front or rear impacts—rear to front in side impacts.  
All measurements in millimeters.

Specific Impact Number	Plane* of C Measurements	Direct Damage		Field L**	C <sub>1</sub>	C <sub>2</sub>	C <sub>3</sub>	C <sub>4</sub>	C <sub>5</sub>	C <sub>6</sub>	±D
		Width ** (CDC)	Max*** Crush								
1	At front bumper	750	380	700	380	350	250	150	70	30	-350
2	Left side -- 700 mm above ground	750	240	940	0	80	Wheel Well			240	+1440

<sup>1</sup>Table taken from NASS.

\*Identify the plane at which the C measurements are taken (e.g., at bumper, above bumper, at sill, above sill, at beltline, etc.) or label adjustments (e.g., free space).

Free space value is defined as the distance between the baseline and the original body contour taken at the individual C locations. This may include the following: bumper lead, bumper taper, side protrusion, side taper, etc. Record the value for each C measurement and maximum crush.

\*\*Measure and document on the vehicle diagram the beginning or end of the direct damage width and field L (e.g., side damage with respect to undamaged axle).

\*\*\*Measure and document on the vehicle diagram the location of the maximum crush.

Note: Use as many lines/columns as necessary to describe each damage profile.

# Truck

## Occupant Compartment Deformation

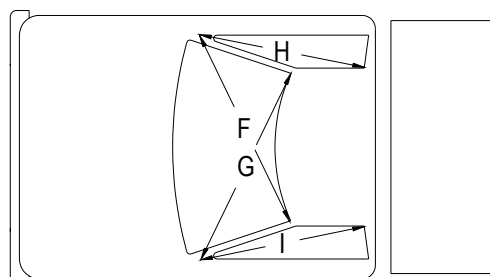

a) Top view of deformation zones.

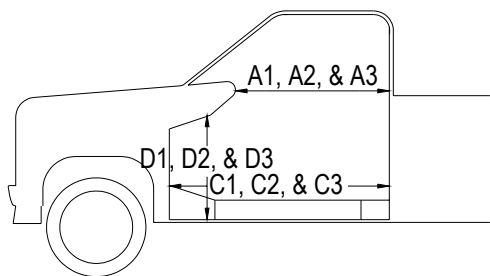

b) Side view of deformation zones.

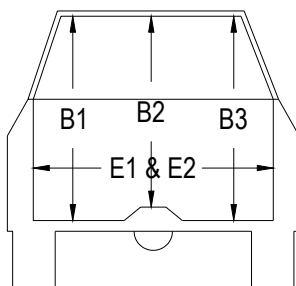

c) End view of deformation zones.

	BEFORE (mm)	AFTER (mm)
A1	867	857
A2	879	879
A3	910	910
B1	1077	1082
B2	1068	980
B3	1070	1070
C1	1378	1367
C2	1255	1255
C3	1375	1375
D1	325	347
D2	159	155
D3	317	317
E1	1597	1600
E2	1593	1623
F	1460	1460
G	1460	1460
H	900	900
I	900	900
J*	1529	1480

\*J = Lateral measurement across cab floor from kickpanel to kickpanel.

Figure 152. Occupant compartment measurements for test 405181-2.



DATE: 04/28/03 TEST NO.: 405181-4 VIN NO.: 2C1MR2299V6754041  
 YEAR: 1997 MAKE: Geo MODEL: Metro  
 TIRE INFLATION PRESSURE: \_\_\_\_\_ ODOMETER: 80824 TIRE SIZE: 155 80R13

MASS DISTRIBUTION (kg) LF 283 RF 262 LR 166 RR 163

DESCRIBE ANY DAMAGE TO VEHICLE PRIOR TO TEST:  
 \_\_\_\_\_  
 \_\_\_\_\_

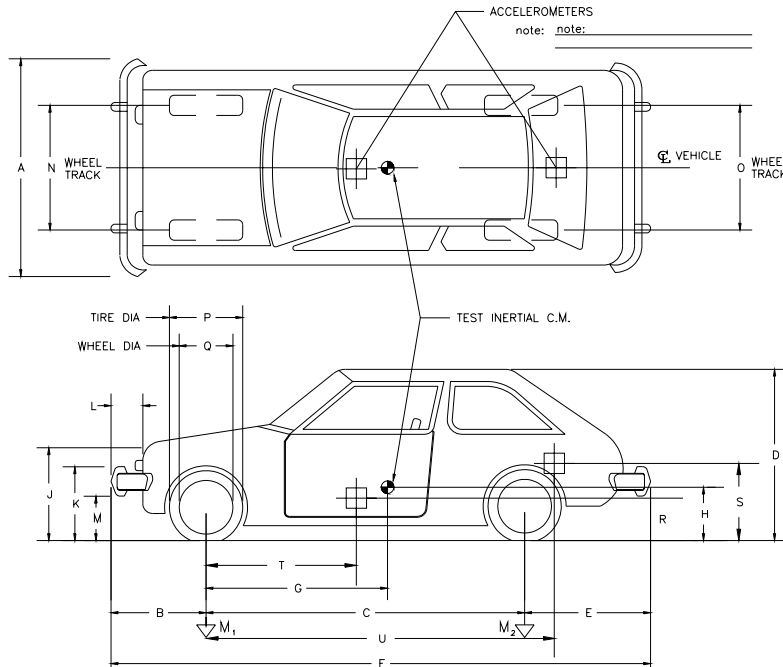

ENGINE TYPE: 4 CYL  
 ENGINE CID: 1.3 L

TRANSMISSION TYPE:  
 AUTO  
 MANUAL

OPTIONAL EQUIPMENT:  
 \_\_\_\_\_  
 \_\_\_\_\_

DUMMY DATA:  
 TYPE: 50th percentile male  
 MASS: 77 kg  
 SEAT POSITION: driver

GEOMETRY - (mm)

A	<u>1450</u>	E	<u>560</u>	J	<u>610</u>	N	<u>1380</u>	R	<u>400</u>
B	<u>790</u>	F	<u>3715</u>	K	<u>525</u>	O	<u>1365</u>	S	<u>550</u>
C	<u>2365</u>	G	<u>890.3</u>	L	<u>160</u>	P	<u>570</u>	T	<u>960</u>
D	<u>1400</u>	H	<u>---</u>	M	<u>400</u>	Q	<u>365</u>	U	<u>2400</u>

MASS - (kg)	CURB	TEST INERTIAL	GROSS STATIC
M <sub>1</sub>	<u>546</u>	<u>545</u>	<u>583</u>
M <sub>2</sub>	<u>309</u>	<u>329</u>	<u>368</u>
M <sub>f</sub>	<u>855</u>	<u>874</u>	<u>951</u>

Figure 153. Vehicle properties for test 405181-4.

Table 24. Exterior crush measurements for test 405181-4.

VEHICLE CRUSH MEASUREMENT SHEET<sup>1</sup>

Complete When Applicable	
End Damage	Side Damage
Undeformed end width _____  Corner shift: A1 _____ A2 _____  End shift at frame (CDC) (check one) < 102 mm _____ ≥ 102 mm _____	Bowing: B1 ____ X1 ____  B2 ____ X2 ____   Bowing constant  $\frac{X1 + X2}{2} = \underline{\hspace{2cm}}$

Note: Measure C1 to C6 from driver to passenger side in front or rear impacts—rear to front in side impacts.  
 All measurements in millimeters.

Specific Impact Number	Plane* of C Measurements	Direct Damage		Field L**	C <sub>1</sub>	C <sub>2</sub>	C <sub>3</sub>	C <sub>4</sub>	C <sub>5</sub>	C <sub>6</sub>	±D
		Width ** (CDC)	Max*** Crush								
1	Above front bumper	200	60	200	0	20	40	60	–	–	+560
2	Right side -- above level of front bumper	200	220	1100	30	50	80	180	200	220	+1100

<sup>1</sup>Table taken from NASS.

\*Identify the plane at which the C measurements are taken (e.g., at bumper, above bumper, at sill, above sill, at beltline, etc.) or label adjustments (e.g., free space).

Free space value is defined as the distance between the baseline and the original body contour taken at the individual C locations. This may include the following: bumper lead, bumper taper, side protrusion, side taper, etc. Record the value for each C measurement and maximum crush.

\*\*Measure and document on the vehicle diagram the beginning or end of the direct damage width and field L (e.g., side damage with respect to undamaged axle).

\*\*\*Measure and document on the vehicle diagram the location of the maximum crush.

Note: Use as many lines/columns as necessary to describe each damage profile.

# Small Car

## Occupant Compartment Deformation

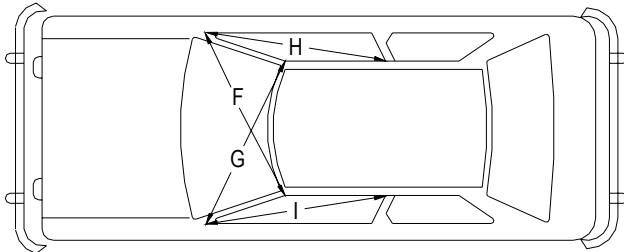

a) Top view of deformation zones.

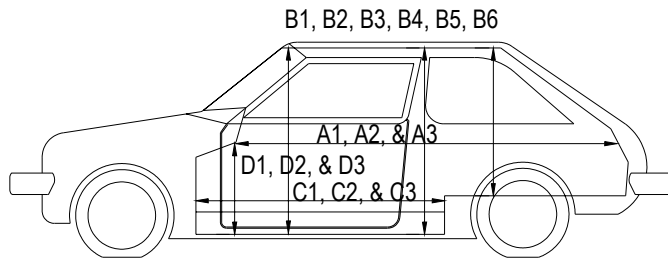

b) Side view of deformation zones.

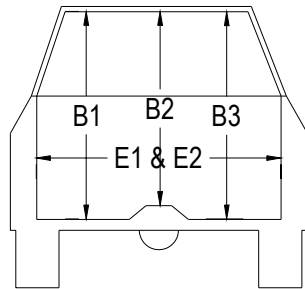

c) End view of deformation zones.

	BEFORE (mm)	AFTER (mm)
A1	1416	1416
A2	2005	2005
A3	1408	1408
B1	960	960
B2	912	912
B3	1005	1005
B4	920	920
B5	900	900
B6	922	922
C1	562	562
C2	---	---
C3	556	556
D1	234	234
D2	123	123
D3	260	260
E1	1220	1220
E2	1180	1180
F	1205	1205
G	1205	1205
H	1175	1175
I	1175	1175
J*	1205	1205

\*J = Lateral measurement across cab floor from kickpanel to kickpanel.

Figure 154. Occupant compartment measurements for test 405181-4.

DATE: 05/06/03 TEST NO.: 405181-3 VIN NO.: 1GCFC24M5WZ231863  
 YEAR: 1998 MAKE: Chevrolet MODEL: 2500 Pickup  
 TIRE INFLATION PRESSURE: \_\_\_\_\_ ODOMETER: 119923 TIRE SIZE: 225 75R16

MASS DISTRIBUTION (kg) LF 554 RF 571 LR 451 RR 424

DESCRIBE ANY DAMAGE TO VEHICLE PRIOR TO TEST:  
 \_\_\_\_\_  
 \_\_\_\_\_

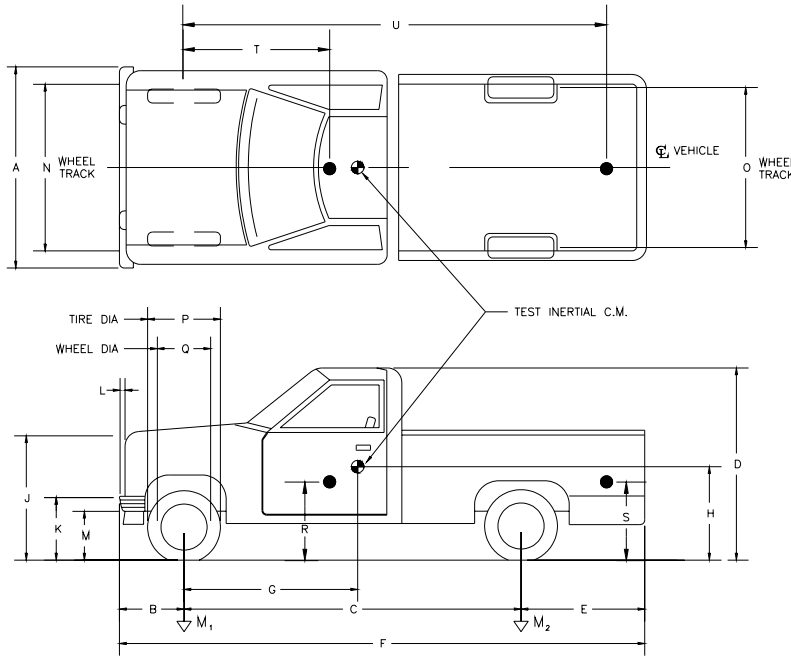

● Denotes accelerometer location.

NOTES: \_\_\_\_\_  
 \_\_\_\_\_

ENGINE TYPE: V-8

ENGINE CID: 5.7 L

TRANSMISSION TYPE:

AUTO

MANUAL

OPTIONAL EQUIPMENT:

6 LUGS

DUMMY DATA:

TYPE: 50th percentile male

MASS: 77 kg

SEAT POSITION: driver

GEOMETRY - (mm)

A	<u>1880</u>	E	<u>1310</u>	J	<u>1038</u>	N	<u>1590</u>	R	<u>700</u>
B	<u>810</u>	F	<u>5470</u>	K	<u>595</u>	O	<u>1610</u>	S	<u>860</u>
C	<u>3350</u>	G	<u>1465.6</u>	L	<u>70</u>	P	<u>725</u>	T	<u>1480</u>
D	<u>1770</u>	H	<u>---</u>	M	<u>378</u>	Q	<u>440</u>	U	<u>3390</u>

MASS - (kg)	CURB	TEST INERTIAL	GROSS STATIC
M <sub>1</sub>	<u>1190</u>	<u>1125</u>	<u>1163</u>
M <sub>2</sub>	<u>898</u>	<u>875</u>	<u>914</u>
M <sub>T</sub>	<u>2088</u>	<u>2000</u>	<u>2077</u>

Figure 155. Vehicle properties for test 405181-3.

Table 25. Exterior crush measurements for test 405181-3.

VEHICLE CRUSH MEASUREMENT SHEET<sup>1</sup>

Complete When Applicable	
End Damage	Side Damage
Undeformed end width _____  Corner shift: A1 _____ A2 _____  End shift at frame (CDC) (check one) < 102 mm _____ ≥ 102 mm _____	Bowing: B1 ____ X1 ____  B2 ____ X2 ____  Bowing constant  $\frac{X1 + X2}{2} = \underline{\hspace{2cm}}$

Note: Measure C1 to C6 from driver to passenger side in front or rear impacts—rear to front in side impacts.  
 All measurements in millimeters.

Specific Impact Number	Plane* of C Measurements	Direct Damage		Field L**	C <sub>1</sub>	C <sub>2</sub>	C <sub>3</sub>	C <sub>4</sub>	C <sub>5</sub>	C <sub>6</sub>	±D
		Width ** (CDC)	Max*** Crush								
1	At front bumper	800	330	800	330	200	150	90	40	0	-400
2	Left side – above level of front bumper	800	460	1700	75	145	Wheel Well		440	460	+1450

<sup>1</sup>Table taken from NASS.

\*Identify the plane at which the C measurements are taken (e.g., at bumper, above bumper, at sill, above sill, at beltline, etc.) or label adjustments (e.g., free space).

Free space value is defined as the distance between the baseline and the original body contour taken at the individual C locations. This may include the following: bumper lead, bumper taper, side protrusion, side taper, etc. Record the value for each C measurement and maximum crush.

\*\*Measure and document on the vehicle diagram the beginning or end of the direct damage width and field L (e.g., side damage with respect to undamaged axle).

\*\*\*Measure and document on the vehicle diagram the location of the maximum crush.

Note: Use as many lines/columns as necessary to describe each damage profile.

# Truck

## Occupant Compartment Deformation

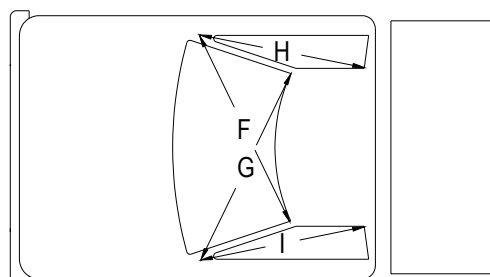

a) Top view of deformation zones.

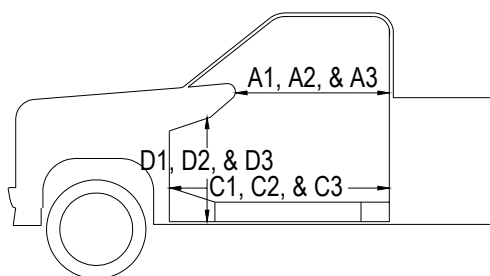

b) Side view of deformation zones.

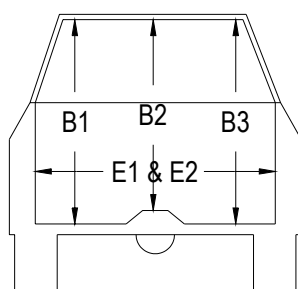

c) End view of deformation zones.

	BEFORE (mm)	AFTER (mm)
A1	871	850
A2	954	950
A3	930	930
B1	1072	1070
B2	994	954
B3	1072	1072
C1	1370	1430
C2	---	---
C3	1371	1371
D1	320	333
D2	153	138
D3	304	304
E1	1592	1598
E2	1590	1618
F	1460	1460
G	1460	1460
H	1250	1245
I	1250	1250
J*	1521	1454

\*J = Lateral measurement across cab floor from kickpanel to kickpanel.

Figure 156. Occupant compartment measurements for test 405181-3.

DATE: 09/19/01 TEST NO.: 405181-13 VIN NO.: 1GCGC24R9VE178168  
 YEAR: 1997 MAKE: Chevrolet MODEL: 2500 Pickup  
 TIRE INFLATION PRESSURE: \_\_\_\_\_ ODOMETER: 172850 TIRE SIZE: LT 245 75 R16

MASS DISTRIBUTION (kg) LF 560 RF 550 LR 450 RR 483

DESCRIBE ANY DAMAGE TO VEHICLE PRIOR TO TEST:

---

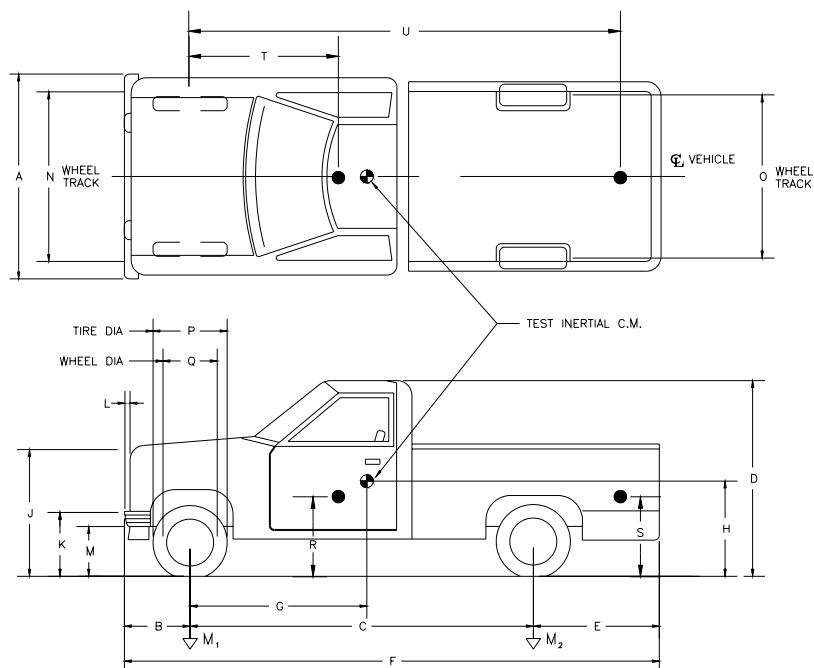

● Denotes accelerometer location.

NOTES: \_\_\_\_\_  
 \_\_\_\_\_  
 \_\_\_\_\_

ENGINE TYPE: 8 CYL

ENGINE CID: 5.7 L

TRANSMISSION TYPE:

AUTO  
 MANUAL

OPTIONAL EQUIPMENT:

\_\_\_\_\_  
 \_\_\_\_\_  
 \_\_\_\_\_

DUMMY DATA:

TYPE: 75th percentile male

MASS: 76 kg

SEAT POSITION: \_\_\_\_\_

GEOMETRY - (mm)

A	<u>1870</u>	E	<u>1310</u>	J	<u>1090</u>	N	<u>1605</u>	R	<u>730</u>
B	<u>820</u>	F	<u>5480</u>	K	<u>655</u>	O	<u>1620</u>	S	<u>910</u>
C	<u>3350</u>	G	<u>1529.9</u>	L	<u>70</u>	P	<u>760</u>	T	<u>1470</u>
D	<u>1860</u>	H	<u>---</u>	M	<u>435</u>	Q	<u>445</u>	U	<u>3350</u>

MASS - (kg)	CURB	TEST INERTIAL	GROSS STATIC
M <sub>1</sub>	<u>1243</u>	<u>1110</u>	<u>1148</u>
M <sub>2</sub>	<u>896</u>	<u>933</u>	<u>971</u>
M <sub>T</sub>	<u>2139</u>	<u>2043</u>	<u>2119</u>

Figure 157. Vehicle properties for test 405181-13.

Table 26. Exterior crush measurements for test 405181-13.

VEHICLE CRUSH MEASUREMENT SHEET<sup>1</sup>

Complete When Applicable	
End Damage	Side Damage
Undeformed end width _____  Corner shift: A1 _____ A2 _____  End shift at frame (CDC) (check one) < 102 mm _____ ≥ 102 mm _____	Bowing: B1 _____ X1 _____  B2 _____ X2 _____   Bowing constant  $\frac{X1 + X2}{2} = \underline{\hspace{2cm}}$

Note: Measure C1 to C6 from driver to passenger side in front or rear impacts—rear to front in side impacts.  
 All measurements in millimeters.

Specific Impact Number	Plane* of C Measurements	Direct Damage		Field L**	C <sub>1</sub>	C <sub>2</sub>	C <sub>3</sub>	C <sub>4</sub>	C <sub>5</sub>	C <sub>6</sub>	±D
		Width ** (CDC)	Max*** Crush								
1	At front bumper	900	400	740	400	310	240	100	50	0	-370
2	Left side – 750 mm above ground	900	290	940	0	55	Wheel Well			290	+1520

<sup>1</sup>Table taken from NASS.

\*Identify the plane at which the C measurements are taken (e.g., at bumper, above bumper, at sill, above sill, at beltline, etc.) or label adjustments (e.g., free space).

Free space value is defined as the distance between the baseline and the original body contour taken at the individual C locations. This may include the following: bumper lead, bumper taper, side protrusion, side taper, etc. Record the value for each C measurement and maximum crush.

\*\*Measure and document on the vehicle diagram the beginning or end of the direct damage width and field L (e.g., side damage with respect to undamaged axle).

\*\*\*Measure and document on the vehicle diagram the location of the maximum crush.

Note: Use as many lines/columns as necessary to describe each damage profile.



# Truck

## Occupant Compartment Deformation

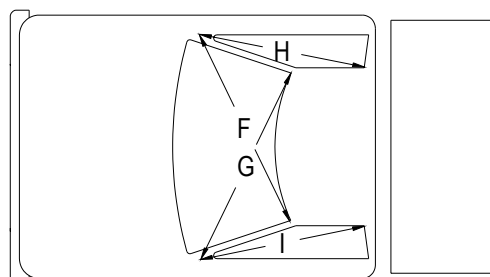

a) Top view of deformation zones.

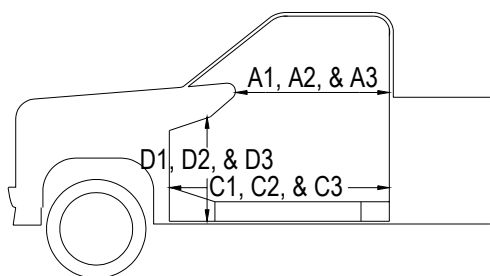

b) Side view of deformation zones.

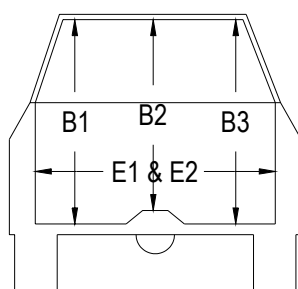

c) End view of deformation zones.

	BEFORE (mm)	AFTER (mm)
A1	870	870
A2	927	927
A3	907	907
B1	1073	1073
B2	1040	1040
B3	1070	1070
C1	1370	1370
C2	527	527
C3	1373	1373
D1	323	323
D2	160	160
D3	311	311
E1	1586	1586
E2	1598	1603
F	1465	1465
G	1465	1465
H	900	900
I	900	900
J*	1523	1523

\*J = Lateral measurement across cab floor from kickpanel to kickpanel.

Figure 158. Occupant compartment measurements for test 405181-13.

DATE: 08/02/01 TEST NO.: 405181-14 VIN NO.: 2C1MRZ299V6736462  
 YEAR: 1997 MAKE: Geo MODEL: Metro  
 TIRE INFLATION PRESSURE: \_\_\_\_\_ ODOMETER: 74579 TIRE SIZE: 155 80R13

1st Use: \_\_\_\_\_ 2nd or More Use: \_\_\_\_\_ Minor Damage Charged to Project: \_\_\_\_\_

MASS DISTRIBUTION (kg) LF 270 RF 255 LR 150 RR 161

DESCRIBE ANY DAMAGE TO VEHICLE PRIOR TO TEST:

CRACK IN WINDSHIELD (MARKED)

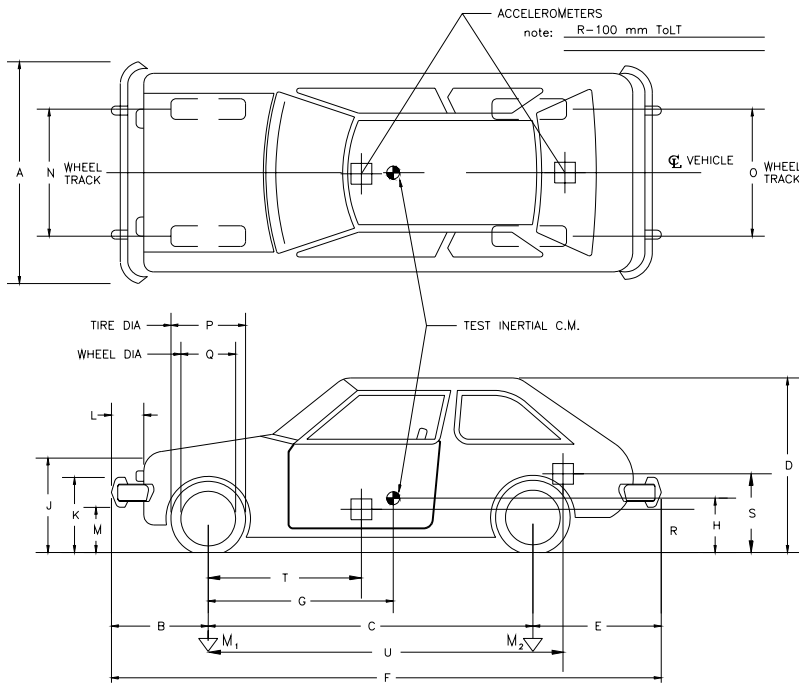

ENGINE TYPE: 4 CYL.  
 ENGINE CID: 1.3L

TRANSMISSION TYPE:  
 AUTO  
 MANUAL

OPTIONAL EQUIPMENT:  
 \_\_\_\_\_  
 \_\_\_\_\_  
 \_\_\_\_\_

DUMMY DATA:  
 TYPE: 50th percentile male  
 MASS: 76 kg  
 SEAT POSITION: Driver

GEOMETRY - (mm)

A	<u>1470</u>	E	<u>560</u>	J	<u>610</u>	N	<u>1375</u>	R	<u>400</u>
B	<u>770</u>	F	<u>3695</u>	K	<u>525</u>	O	<u>1365</u>	S	<u>580</u>
C	<u>2365</u>	G	<u>896.9</u>	L	<u>160</u>	P	<u>570</u>	T	<u>940</u>
D	<u>1430</u>	H	<u>---</u>	M	<u>400</u>	Q	<u>365</u>	U	<u>2500</u>

MASS - (kg)	CURB	TEST INERTIAL	GROSS STATIC
M <sub>1</sub>	<u>547</u>	<u>525</u>	<u>563</u>
M <sub>2</sub>	<u>302</u>	<u>311</u>	<u>349</u>
M <sub>T</sub>	<u>849</u>	<u>836</u>	<u>912</u>

Figure 159. Vehicle properties for test 405181-14.

Table 27. Exterior crush measurements for test 405181-14.

VEHICLE CRUSH MEASUREMENT SHEET<sup>1</sup>

Complete When Applicable	
End Damage	Side Damage
Undeformed end width _____  Corner shift: A1 _____ A2 _____  End shift at frame (CDC) (check one) < 102 mm _____ ≥ 102 mm _____	Bowing: B1 ____ X1 ____  B2 ____ X2 ____   Bowing constant  $\frac{X1 + X2}{2} = \underline{\hspace{2cm}}$

Note: Measure C1 to C6 from driver to passenger side in front or rear impacts—rear to front in side impacts.  
 All measurements in millimeters.

Specific Impact Number	Plane* of C Measurements	Direct Damage		Field L**	C <sub>1</sub>	C <sub>2</sub>	C <sub>3</sub>	C <sub>4</sub>	C <sub>5</sub>	C <sub>6</sub>	±D
		Width ** (CDC)	Max*** Crush								
1	At front bumper	500	100	680	100	70	30	30	10	0	-340
2	Left side – 560 mm above ground	600	160	760	0	30	35	65	90	160	+1140

<sup>1</sup>Table taken from NASS.

\*Identify the plane at which the C measurements are taken (e.g., at bumper, above bumper, at sill, above sill, at beltline, etc.) or label adjustments (e.g., free space).

Free space value is defined as the distance between the baseline and the original body contour taken at the individual C locations. This may include the following: bumper lead, bumper taper, side protrusion, side taper, etc. Record the value for each C measurement and maximum crush.

\*\*Measure and document on the vehicle diagram the beginning or end of the direct damage width and field L (e.g., side damage with respect to undamaged axle).

\*\*\*Measure and document on the vehicle diagram the location of the maximum crush.

Note: Use as many lines/columns as necessary to describe each damage profile.

# Small Car

## Occupant Compartment Deformation

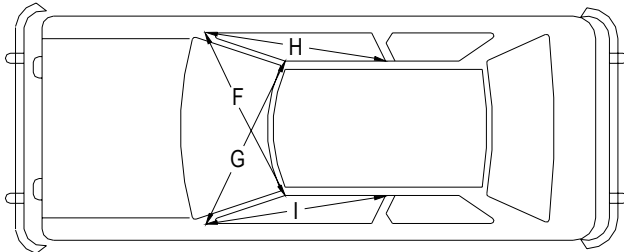

a) Top view of deformation zones.

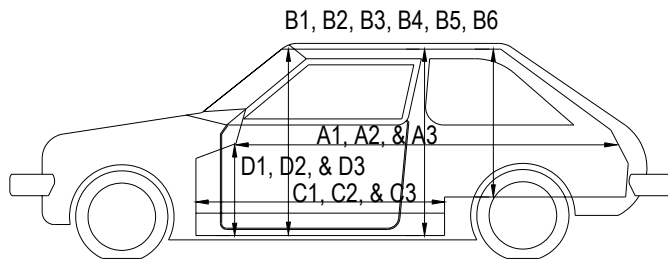

b) Side view of deformation zones.

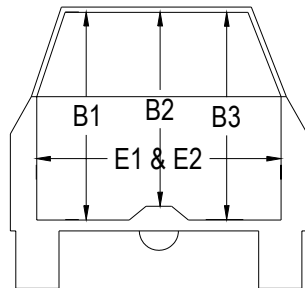

c) End view of deformation zones.

	BEFORE (mm)	AFTER (mm)
A1	1422	1422
A2	1990	1990
A3	1425	1425
B1	965	967
B2	958	958
B3	972	972
B4	930	930
B5	905	905
B6	925	925
C1	700	700
C2	705	705
C3	710	710
D1	247	255
D2	120	120
D3	237	237
E1	1222	1222
E2	1180	1190
F	1210	1210
G	1210	1210
H	900	900
I	900	900
J*	1185	1178

\*J = Lateral measurement across cab floor from kickpanel to kickpanel.

Figure 160. Occupant compartment measurements for test 405181-14.

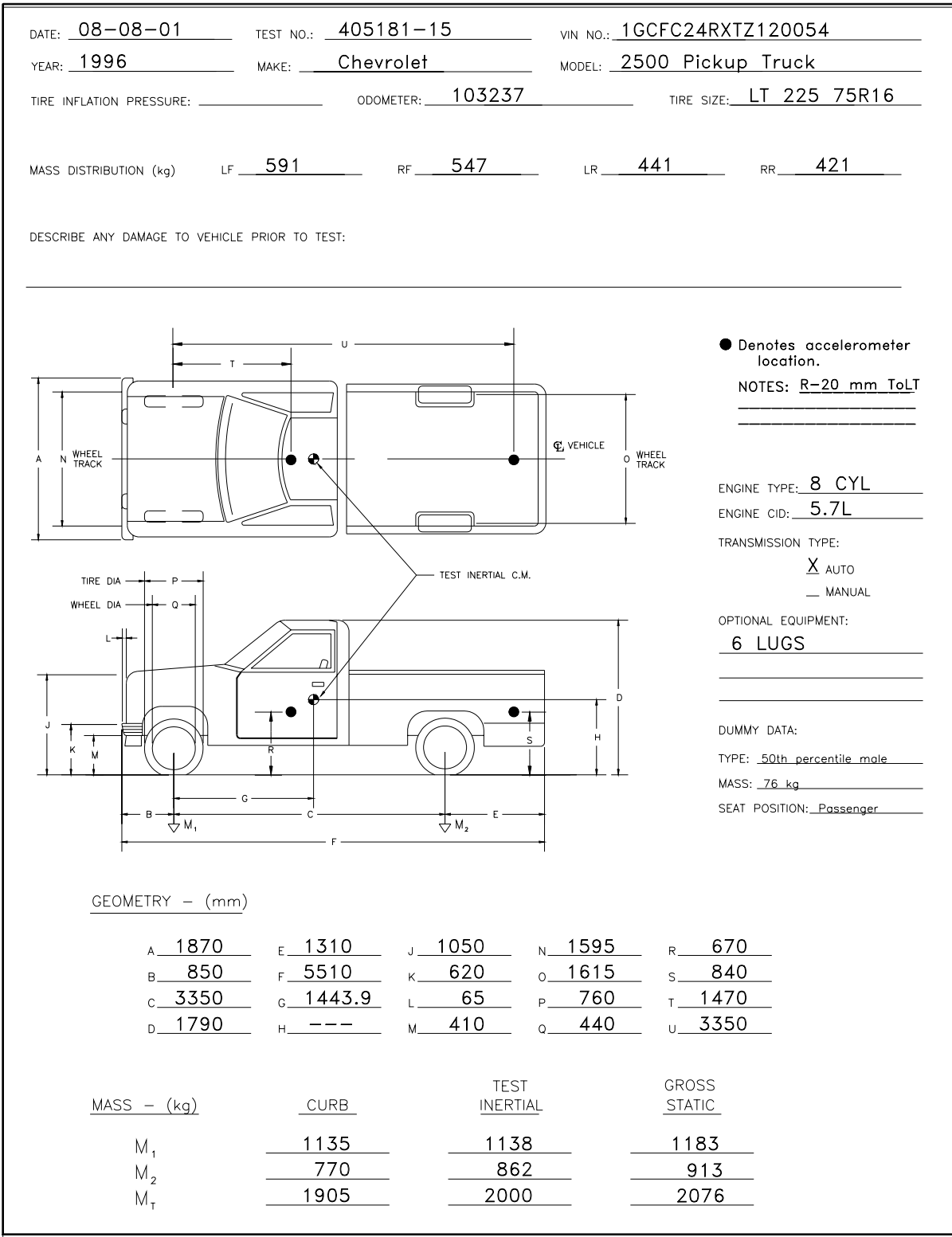

Figure 161. Vehicle properties for test 405181-15.

Table 28. Exterior crush measurements for test 405181-15.

VEHICLE CRUSH MEASUREMENT SHEET<sup>1</sup>

Complete When Applicable	
End Damage	Side Damage
Undeformed end width _____  Corner shift: A1 _____ A2 _____  End shift at frame (CDC) (check one) < 102 mm _____ ≥ 102 mm _____	Bowing: B1 ____ X1 ____  B2 ____ X2 ____   Bowing constant  $\frac{X1 + X2}{2} = \underline{\hspace{2cm}}$

Note: Measure C1 to C6 from driver to passenger side in front or rear impacts—rear to front in side impacts.  
 All measurements in millimeters.

Specific Impact Number	Plane* of C Measurements	Direct Damage		Field L**	C <sub>1</sub>	C <sub>2</sub>	C <sub>3</sub>	C <sub>4</sub>	C <sub>5</sub>	C <sub>6</sub>	±D
		Width ** (CDC)	Max*** Crush								
1	At front bumper	800	350	800	0	100	190	250	340	350	+400
2	Right side – 770 mm above ground	800	340	1000	330	340	N/A	N/A	30	0	+1700

<sup>1</sup>Table taken from NASS.

\*Identify the plane at which the C measurements are taken (e.g., at bumper, above bumper, at sill, above sill, at beltline, etc.) or label adjustments (e.g., free space).

Free space value is defined as the distance between the baseline and the original body contour taken at the individual C locations. This may include the following: bumper lead, bumper taper, side protrusion, side taper, etc. Record the value for each C measurement and maximum crush.

\*\*Measure and document on the vehicle diagram the beginning or end of the direct damage width and field L (e.g., side damage with respect to undamaged axle).

\*\*\*Measure and document on the vehicle diagram the location of the maximum crush.

Note: Use as many lines/columns as necessary to describe each damage profile.

# Truck

## Occupant Compartment Deformation

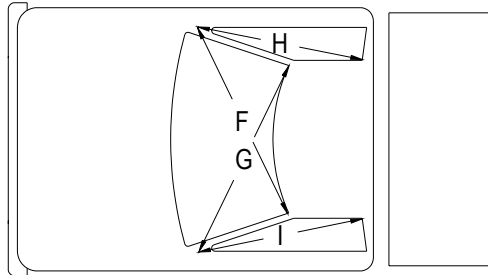

a) Top view of deformation zones.

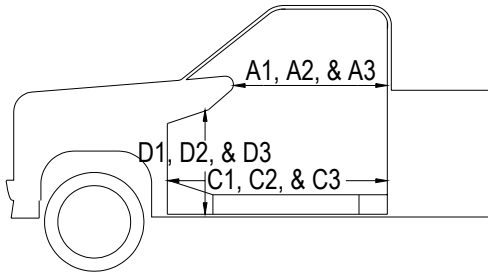

b) Side view of deformation zones.

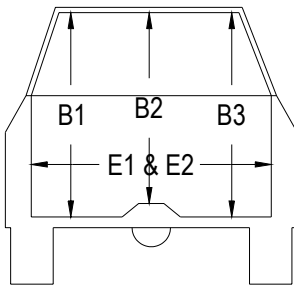

c) End view of deformation zones.

	BEFORE (mm)	AFTER (mm)
A1	865	865
A2	880	880
A3	905	905
B1	1075	1075
B2	1050	1050
B3	1070	1070
C1	1378	1378
C2	533	533
C3	1373	1368
D1	320	320
D2	155	155
D3	317	308
E1	1582	1582
E2	1587	1587
F	1465	1465
G	1465	1465
H	900	900
I	900	900
J*	1524	1519

\*J = Lateral measurement across cab floor from kickpanel to kickpanel.

Figure 162. Occupant compartment measurements for test 405181-15.

DATE: 03/05/03 TEST NO.: 405181-19 VIN NO.: 2C1MR2262V6722313  
 YEAR: 1997 MAKE: Geo MODEL: Metro  
 TIRE INFLATION PRESSURE: \_\_\_\_\_ ODOMETER: 47970 TIRE SIZE: 155 80R13

MASS DISTRIBUTION (kg) LF 245 RF 245 LR 166 RR 164

DESCRIBE ANY DAMAGE TO VEHICLE PRIOR TO TEST:  
 \_\_\_\_\_  
 \_\_\_\_\_

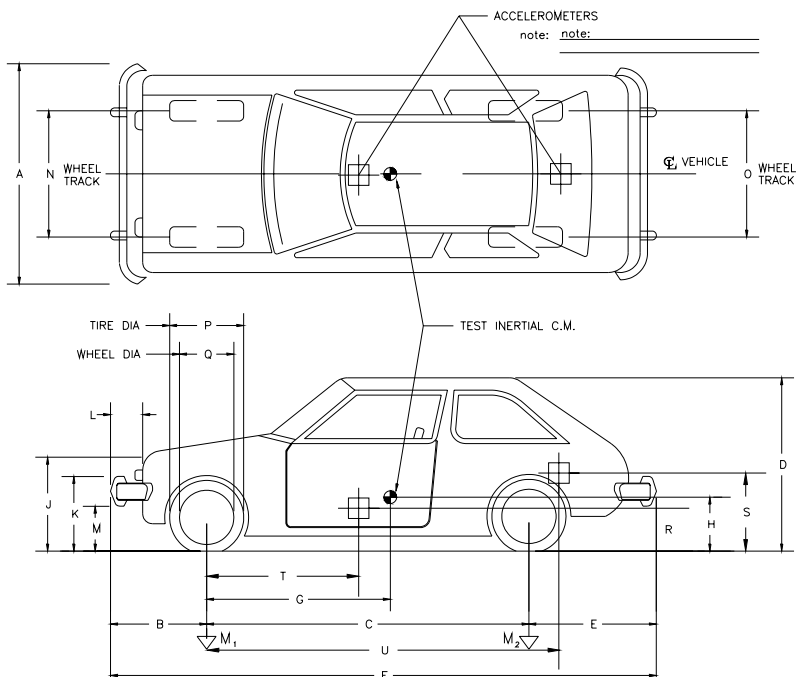

ENGINE TYPE: 3 CYL  
 ENGINE CID: 1.0 L  
 TRANSMISSION TYPE:  
 AUTO  
 MANUAL  
 OPTIONAL EQUIPMENT:  
 \_\_\_\_\_  
 \_\_\_\_\_  
 DUMMY DATA:  
 TYPE: 50th percentile male  
 MASS: 77 kg  
 SEAT POSITION: driver

GEOMETRY - (mm)

A	<u>1450</u>	E	<u>560</u>	J	<u>610</u>	N	<u>1380</u>	R	<u>400</u>
B	<u>790</u>	F	<u>3715</u>	K	<u>525</u>	O	<u>1365</u>	S	<u>550</u>
C	<u>2365</u>	G	<u>951.8</u>	L	<u>160</u>	P	<u>570</u>	T	<u>960</u>
D	<u>1400</u>	H	<u>---</u>	M	<u>400</u>	Q	<u>365</u>	U	<u>2400</u>

MASS - (kg)	CURB	TEST INERTIAL	GROSS STATIC
M <sub>1</sub>	<u>495</u>	<u>490</u>	<u>528</u>
M <sub>2</sub>	<u>302</u>	<u>330</u>	<u>369</u>
M <sub>T</sub>	<u>797</u>	<u>820</u>	<u>897</u>

Figure 163. Vehicle properties for test 405181-19.



Table 29. Exterior crush measurements for test 405181-19.

VEHICLE CRUSH MEASUREMENT SHEET<sup>1</sup>

Complete When Applicable	
End Damage	Side Damage
Undeformed end width _____  Corner shift: A1 _____ A2 _____  End shift at frame (CDC) (check one) < 102 mm _____ ≥ 102 mm _____	Bowing: B1 _____ X1 _____  B2 _____ X2 _____   Bowing constant  $\frac{X1 + X2}{2} = \underline{\hspace{2cm}}$

Note: Measure C1 to C6 from driver to passenger side in front or rear impacts—rear to front in side impacts.  
All measurements in millimeters.

Specific Impact Number	Plane* of C Measurements	Direct Damage		Field L**	C <sub>1</sub>	C <sub>2</sub>	C <sub>3</sub>	C <sub>4</sub>	C <sub>5</sub>	C <sub>6</sub>	±D
		Width ** (CDC)	Max*** Crush								
1	At front bumper	610	260	160	260	180	30	10	-	-	-620
2	Left side – 420 mm above ground	610	220	1150	230	100	N/A		10	5	+1200

<sup>1</sup>Table taken from NASS.

\*Identify the plane at which the C measurements are taken (e.g., at bumper, above bumper, at sill, above sill, at beltline, etc.) or label adjustments (e.g., free space).

Free space value is defined as the distance between the baseline and the original body contour taken at the individual C locations. This may include the following: bumper lead, bumper taper, side protrusion, side taper, etc. Record the value for each C measurement and maximum crush.

\*\*Measure and document on the vehicle diagram the beginning or end of the direct damage width and field L (e.g., side damage with respect to undamaged axle).

\*\*\*Measure and document on the vehicle diagram the location of the maximum crush.

Note: Use as many lines/columns as necessary to describe each damage profile.

# Small Car

## Occupant Compartment Deformation

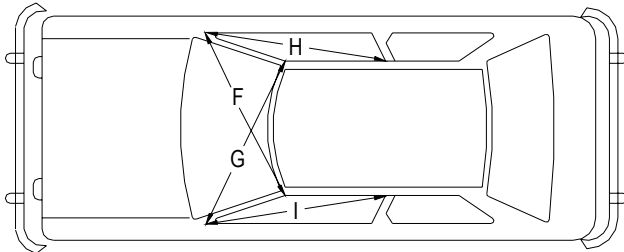

a) Top view of deformation zones.

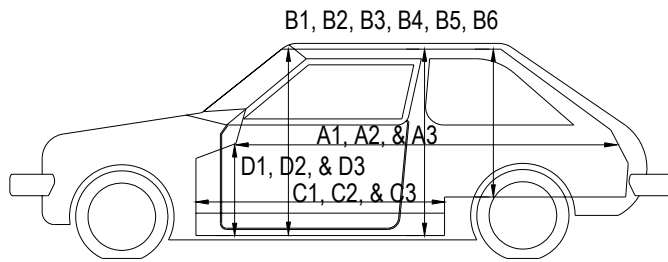

b) Side view of deformation zones.

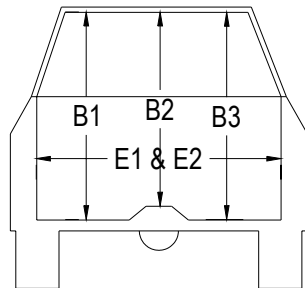

c) End view of deformation zones.

	BEFORE (mm)	AFTER (mm)
A1	1412	1412
A2	2003	2003
A3	1586	1586
B1	964	964
B2	968	968
B3	971	971
B4	926	926
B5	904	904
B6	930	930
C1	567	567
C2	725	725
C3	563	563
D1	251	251
D2	203	203
D3	250	250
E1	1207	1207
E2	1164	1164
F	1205	1205
G	1205	1205
H	1240	1240
I	1240	1240
J*	1191	1191

\*J = Lateral measurement across cab floor from kickpanel to kickpanel.

Figure 164. Occupant compartment measurements for test 405181-19.

DATE: 03/07/03 TEST NO.: 405181-20 VIN NO.: 1GTGC24R7WZ523241  
 YEAR: 1998 MAKE: Chevrolet MODEL: 2500 Pickup  
 TIRE INFLATION PRESSURE: \_\_\_\_\_ ODOMETER: 100705 TIRE SIZE: 245 75R16

MASS DISTRIBUTION (kg) LF 574 RF 582 LR 453 RR 441

DESCRIBE ANY DAMAGE TO VEHICLE PRIOR TO TEST:  
 \_\_\_\_\_  
 \_\_\_\_\_

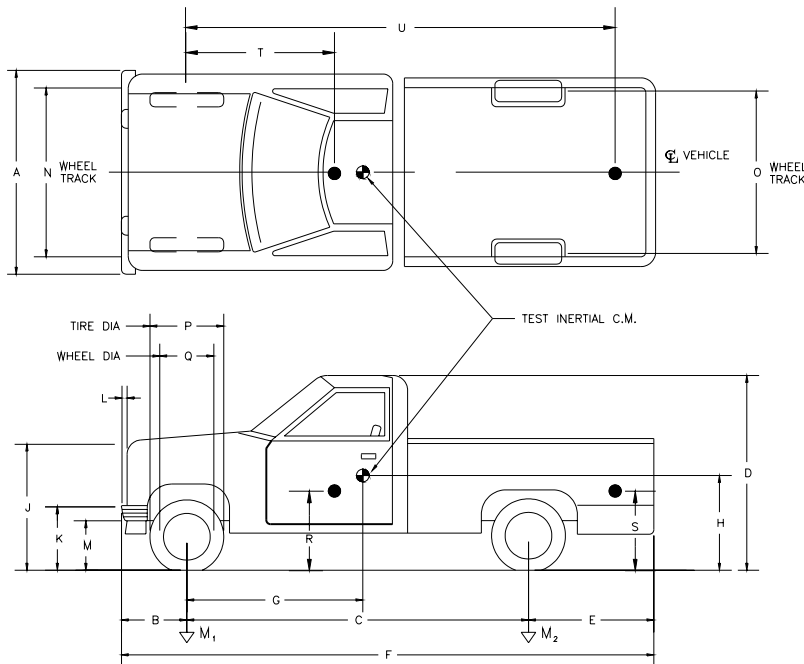

● Denotes accelerometer location.

NOTES: \_\_\_\_\_  
 \_\_\_\_\_

ENGINE TYPE: V-8  
 ENGINE CID: 5.7 L

TRANSMISSION TYPE:  
 \_\_\_\_\_ AUTO  
 MANUAL

OPTIONAL EQUIPMENT:  
8 LUG  
 \_\_\_\_\_  
 \_\_\_\_\_

DUMMY DATA:  
 TYPE: 50th percentile male  
 MASS: 77 kg  
 SEAT POSITION: passenger

GEOMETRY - (mm)

A	<u>1880</u>	E	<u>1310</u>	J	<u>1038</u>	N	<u>1590</u>	R	<u>750</u>
B	<u>810</u>	F	<u>5470</u>	K	<u>635</u>	O	<u>1610</u>	S	<u>900</u>
C	<u>3350</u>	G	<u>1460.9</u>	L	<u>70</u>	P	<u>725</u>	T	<u>1460</u>
D	<u>1820</u>	H	<u>---</u>	M	<u>415</u>	Q	<u>440</u>	U	<u>3360</u>

MASS - (kg)	CURB	TEST INERTIAL	GROSS STATIC
M <sub>1</sub>	<u>1228</u>	<u>1156</u>	<u>1195</u>
M <sub>2</sub>	<u>928</u>	<u>894</u>	<u>932</u>
M <sub>T</sub>	<u>2156</u>	<u>2050</u>	<u>2127</u>

Figure 165. Vehicle properties for test 405181-20.

Table 30. Exterior crush measurements for test 405181-20.

VEHICLE CRUSH MEASUREMENT SHEET<sup>1</sup>

Complete When Applicable	
End Damage	Side Damage
Undeformed end width _____  Corner shift: A1 _____ A2 _____  End shift at frame (CDC) (check one) < 102 mm _____ ≥ 102 mm _____	Bowing: B1 ____ X1 ____  B2 ____ X2 ____   Bowing constant  $\frac{X1 + X2}{2} = \underline{\hspace{2cm}}$

Note: Measure C1 to C6 from driver to passenger side in front or rear impacts—rear to front in side impacts.  
All measurements in millimeters.

Specific Impact Number	Plane* of C Measurements	Direct Damage		Field L**	C <sub>1</sub>	C <sub>2</sub>	C <sub>3</sub>	C <sub>4</sub>	C <sub>5</sub>	C <sub>6</sub>	±D
		Width ** (CDC)	Max*** Crush								
1	At front bumper	1040	120	600	0	25	90	100	110	120	+610
2	Right side – at front bumper height	1040	80	1200	0	20	N/A		70	80	+1575

<sup>1</sup>Table taken from NASS.

\*Identify the plane at which the C measurements are taken (e.g., at bumper, above bumper, at sill, above sill, at beltline, etc.) or label adjustments (e.g., free space).

Free space value is defined as the distance between the baseline and the original body contour taken at the individual C locations. This may include the following: bumper lead, bumper taper, side protrusion, side taper, etc. Record the value for each C measurement and maximum crush.

\*\*Measure and document on the vehicle diagram the beginning or end of the direct damage width and field L (e.g., side damage with respect to undamaged axle).

\*\*\*Measure and document on the vehicle diagram the location of the maximum crush.

Note: Use as many lines/columns as necessary to describe each damage profile.

# Truck

## Occupant Compartment Deformation

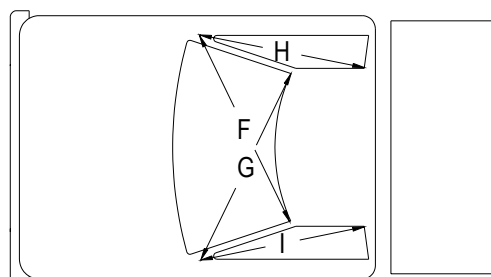

a) Top view of deformation zones.

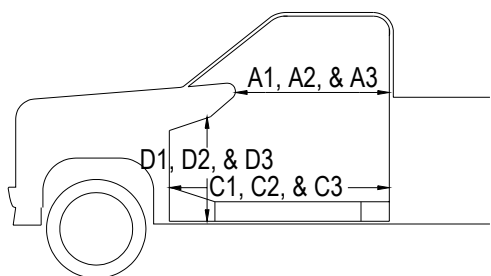

b) Side view of deformation zones.

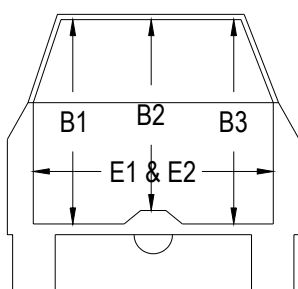

c) End view of deformation zones.

	BEFORE (mm)	AFTER (mm)
A1	866	866
A2	944	944
A3	928	928
B1	1080	1080
B2	1004	1004
B3	1075	1075
C1	1376	1376
C2	---	---
C3	1371	1371
D1	320	320
D2	160	160
D3	305	305
E1	1586	1586
E2	1592	1592
F	1470	1470
G	1470	1470
H	1240	1240
I	1250	1250
J*	1525	1525

\*J = Lateral measurement across cab floor from kickpanel to kickpanel.

Figure 166. Occupant compartment measurements for test 405181-20.

DATE: 07-25-01 TEST NO.: 405181-9 VIN NO.: 1GCFC24M5TZ136585  
 YEAR: 1996 MAKE: Chevrolet MODEL: 2500 Pickup Truck  
 TIRE INFLATION PRESSURE: \_\_\_\_\_ ODOMETER: 146161 TIRE SIZE: LT 225 75R16

MASS DISTRIBUTION (kg) LF 567 RF 552 LR 445 RR 436

DESCRIBE ANY DAMAGE TO VEHICLE PRIOR TO TEST:  
 \_\_\_\_\_

● Denotes accelerometer location.  
 NOTES: \_\_\_\_\_  
 \_\_\_\_\_

ENGINE TYPE: 8 CYL  
 ENGINE CID: 5.7L  
 TRANSMISSION TYPE:  
 \_\_\_\_\_ AUTO  
 MANUAL

OPTIONAL EQUIPMENT:  
6 LUGS  
 \_\_\_\_\_

DUMMY DATA:  
 TYPE: 50th percentile male  
 MASS: .76 kg  
 SEAT POSITION: Driver

**GEOMETRY - (mm)**

A	<u>1870</u>	E	<u>1310</u>	J	<u>1050</u>	N	<u>1595</u>	R	<u>670</u>
B	<u>850</u>	F	<u>5210</u>	K	<u>620</u>	O	<u>1620</u>	S	<u>850</u>
C	<u>3350</u>	G	<u>1475.7</u>	L	<u>650</u>	P	<u>760</u>	T	<u>1470</u>
D	<u>1790</u>	H	<u>---</u>	M	<u>410</u>	Q	<u>440</u>	U	<u>3400</u>

MASS - (kg)	CURB	TEST INERTIAL	GROSS STATIC
M <sub>1</sub>	<u>1132</u>	<u>1119</u>	<u>1167</u>
M <sub>2</sub>	<u>785</u>	<u>881</u>	<u>909</u>
M <sub>T</sub>	<u>1917</u>	<u>2000</u>	<u>2076</u>

Figure 167. Vehicle properties for test 405181-9.

Table 31. Exterior crush measurements for test 405181-9.

VEHICLE CRUSH MEASUREMENT SHEET<sup>1</sup>

Complete When Applicable	
End Damage	Side Damage
<p>Undeformed end width _____</p> <p>Corner shift: A1 _____</p> <p style="padding-left: 40px;">A2 _____</p> <p>End shift at frame (CDC) (check one)</p> <p style="padding-left: 20px;">&lt; 102 mm _____</p> <p style="padding-left: 20px;">≥ 102 mm _____</p>	<p>Bowing: B1 ____ X1 ____</p> <p style="padding-left: 40px;">B2 ____ X2 ____</p> <p>Bowing constant</p> <p><math>\frac{X1 + X2}{2} =</math> _____</p>

Note: Measure C1 to C6 from driver to passenger side in front or rear impacts—rear to front in side impacts.  
All measurements in millimeters.

Specific Impact Number	Plane* of C Measurements	Direct Damage		Field L**	C <sub>1</sub>	C <sub>2</sub>	C <sub>3</sub>	C <sub>4</sub>	C <sub>5</sub>	C <sub>6</sub>	±D
		Width ** (CDC)	Max*** Crush								
1	At front bumper	1200	550	700	550	400	320	190	70	5	-350
2	Left side – 830 mm above ground	1000	360	1000	90	110	210	220	270	360	+1400

<sup>1</sup>Table taken from NASS.

\*Identify the plane at which the C measurements are taken (e.g., at bumper, above bumper, at sill, above sill, at beltline, etc.) or label adjustments (e.g., free space).

Free space value is defined as the distance between the baseline and the original body contour taken at the individual C locations. This may include the following: bumper lead, bumper taper, side protrusion, side taper, etc. Record the value for each C measurement and maximum crush.

\*\*Measure and document on the vehicle diagram the beginning or end of the direct damage width and field L (e.g., side damage with respect to undamaged axle).

\*\*\*Measure and document on the vehicle diagram the location of the maximum crush.

Note: Use as many lines/columns as necessary to describe each damage profile.

# Truck

## Occupant Compartment Deformation

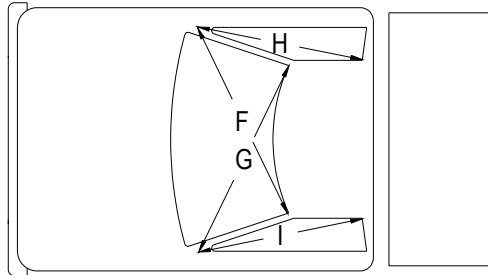

a) Top view of deformation zones.

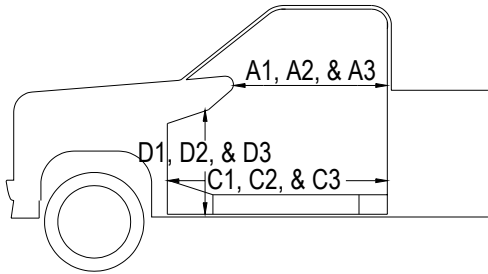

b) Side view of deformation zones.

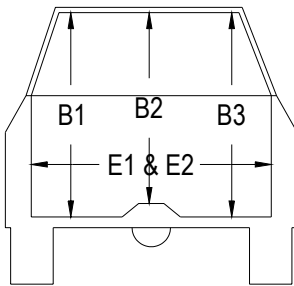

c) End view of deformation zones.

	BEFORE (mm)	AFTER (mm)
A1	869	795
A2	877	840
A3	910	910
B1	1061	1156
B2	1125	1025
B3	1060	1035
C1	1375	1335
C2	1258	1245
C3	1372	1372
D1	327	380
D2	165	135
D3	305	315
E1	1579	1620
E2	1587	1668
F	1455	1365
G	1455	1525
H	900	890
I	900	870
J*	1522	1465

\*J = Lateral measurement across cab floor from kickpanel to kickpanel.

Figure 168. Occupant compartment measurements for test 405181-9.



DATE: 06/20/01 TEST NO.: 405181-11 VIN NO.: 2C1MR2293V6707670  
 YEAR: 1997 MAKE: GEO MODEL: METRO  
 TIRE INFLATION PRESSURE: \_\_\_\_\_ ODOMETER: 107345 TIRE SIZE: 155 80R13

1st Use: \_\_\_\_\_ 2nd or More Use: \_\_\_\_\_ Minor Damage Charged to Project: \_\_\_\_\_

MASS DISTRIBUTION (kg) LF 265 RF 247 LR 156 RR 152

DESCRIBE ANY DAMAGE TO VEHICLE PRIOR TO TEST:  
 \_\_\_\_\_  
 \_\_\_\_\_

ACCELEROMETERS  
note: \_\_\_\_\_

ENGINE TYPE: 4 CYL.  
 ENGINE CID: 1.3L  
 TRANSMISSION TYPE:  
 AUTO  
 MANUAL  
 OPTIONAL EQUIPMENT:  
 \_\_\_\_\_  
 \_\_\_\_\_  
 DUMMY DATA:  
 TYPE: 50th percentile male  
 MASS: 76 kg  
 SEAT POSITION: Driver

GEOMETRY - (mm)

A	<u>1450</u>	E	<u>560</u>	J	<u>610</u>	N	<u>1380</u>	R	<u>410</u>
B	<u>730</u>	F	<u>3655</u>	K	<u>525</u>	O	<u>1365</u>	S	<u>560</u>
C	<u>2365</u>	G	<u>888.3</u>	L	<u>160</u>	P	<u>570</u>	T	<u>940</u>
D	<u>1430</u>	H	<u>---</u>	M	<u>400</u>	Q	<u>365</u>	U	<u>2470</u>

MASS - (kg)	CURB	TEST INERTIAL	GROSS STATIC
M <sub>1</sub>	<u>547</u>	<u>512</u>	<u>547</u>
M <sub>2</sub>	<u>298</u>	<u>308</u>	<u>349</u>
M <sub>T</sub>	<u>845</u>	<u>820</u>	<u>896</u>

Figure 169. Vehicle properties for test 405181-11.



# Small Car

## Occupant Compartment Deformation

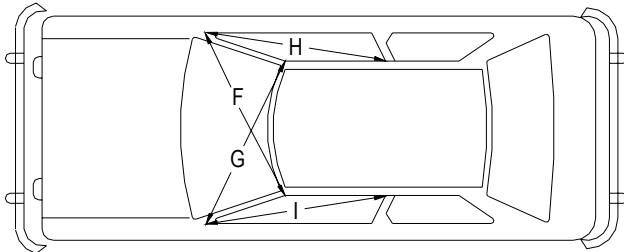

a) Top view of deformation zones.

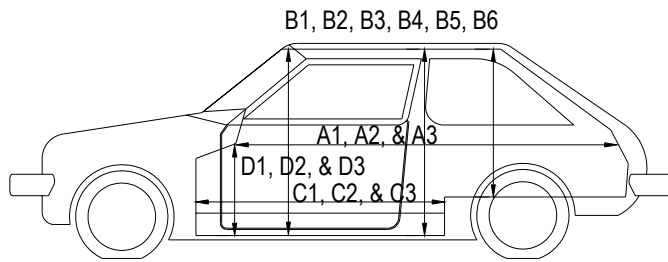

b) Side view of deformation zones.

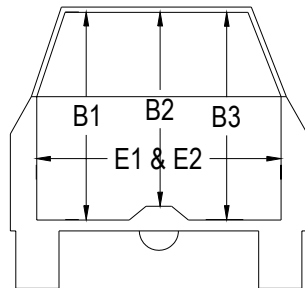

c) End view of deformation zones.

	BEFORE (mm)	AFTER (mm)
A1	1430	1430
A2	2002	2008
A3	1435	1430
B1	965	965
B2	963	963
B3	960	970
B4	921	921
B5	900	900
B6	951	951
C1	702	702
C2	700	700
C3	702	682
D1	230	230
D2	120	112
D3	242	260
E1	1207	1227
E2	1185	1190
F	1205	1205
G	1205	1205
H	1000	1000
I	1000	1000
J*	1185	1145

\*J = Lateral measurement across cab floor from kickpanel to kickpanel.

Figure 170. Occupant compartment measurements for test 405181-11.

DATE: 07-23-01 TEST NO.: 405181-12 VIN NO.: 1GCGC24R8VZ151066  
YEAR: 1997 MAKE: Chevrolet MODEL: 2500 Pickup Truck  
TIRE INFLATION PRESSURE: \_\_\_\_\_ ODOMETER: 146848 TIRE SIZE: LT 245 75R16

MASS DISTRIBUTION (kg) LF 599 RF 558 LR 445 RR 439

DESCRIBE ANY DAMAGE TO VEHICLE PRIOR TO TEST:  
\_\_\_\_\_  
\_\_\_\_\_

● Denotes accelerometer location.  
NOTES: \_\_\_\_\_  
\_\_\_\_\_

ENGINE TYPE: 8 CYL  
ENGINE CID: 5.7L  
TRANSMISSION TYPE:  
 AUTO  
 MANUAL

OPTIONAL EQUIPMENT:  
8 LUGS  
\_\_\_\_\_  
\_\_\_\_\_

DUMMY DATA:  
TYPE: 50th percentile male  
MASS: 76 kg  
SEAT POSITION: Driver

GEOMETRY - (mm)

A	<u>1870</u>	E	<u>1320</u>	J	<u>1090</u>	N	<u>1595</u>	R	<u>720</u>
B	<u>820</u>	F	<u>5490</u>	K	<u>655</u>	O	<u>1615</u>	S	<u>920</u>
C	<u>3350</u>	G	<u>1451.0</u>	L	<u>70</u>	P	<u>760</u>	T	<u>1450</u>
D	<u>1860</u>	H	<u>---</u>	M	<u>435</u>	Q	<u>445</u>	U	<u>3400</u>

MASS - (kg)	CURB	TEST INERTIAL	GROSS STATIC
M <sub>1</sub>	<u>1224</u>	<u>1157</u>	<u>1200</u>
M <sub>2</sub>	<u>907</u>	<u>884</u>	<u>916</u>
M <sub>T</sub>	<u>2131</u>	<u>2000</u>	<u>2116</u>

Figure 171. Vehicle properties for test 405181-12.

Table 33. Exterior crush measurements for test 405181-12.

VEHICLE CRUSH MEASUREMENT SHEET<sup>1</sup>

Complete When Applicable	
End Damage	Side Damage
Undeformed end width _____  Corner shift: A1 _____ A2 _____  End shift at frame (CDC) (check one) < 102 mm _____ ≥ 102 mm _____	Bowing: B1 _____ X1 _____  B2 _____ X2 _____  Bowing constant  $\frac{X1 + X2}{2} = \underline{\hspace{2cm}}$

Note: Measure C1 to C6 from driver to passenger side in front or rear impacts—rear to front in side impacts.  
 All measurements in millimeters.

Specific Impact Number	Plane* of C Measurements	Direct Damage		Field L**	C <sub>1</sub>	C <sub>2</sub>	C <sub>3</sub>	C <sub>4</sub>	C <sub>5</sub>	C <sub>6</sub>	±D
		Width ** (CDC)	Max*** Crush								
1	At front bumper	1040	680	1500	370	330	340	320	250	680	0
2	Right side -- 700 mm above ground	1040	300	1900	10	60	85	210	Wheel Well	300	+950

<sup>1</sup>Table taken from NASS.

\*Identify the plane at which the C measurements are taken (e.g., at bumper, above bumper, at sill, above sill, at beltline, etc.) or label adjustments (e.g., free space).

Free space value is defined as the distance between the baseline and the original body contour taken at the individual C locations. This may include the following: bumper lead, bumper taper, side protrusion, side taper, etc. Record the value for each C measurement and maximum crush.

\*\*Measure and document on the vehicle diagram the beginning or end of the direct damage width and field L (e.g., side damage with respect to undamaged axle).

\*\*\*Measure and document on the vehicle diagram the location of the maximum crush.

Note: Use as many lines/columns as necessary to describe each damage profile.

# Truck

## Occupant Compartment Deformation

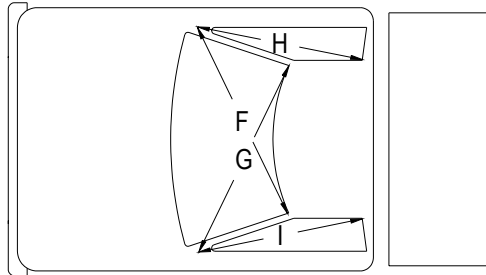

a) Top view of deformation zones.

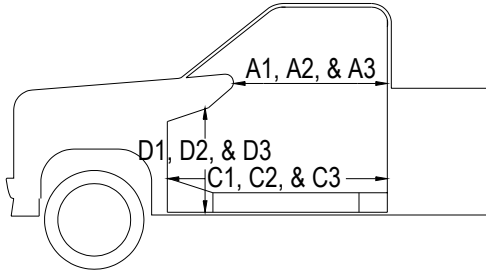

b) Side view of deformation zones.

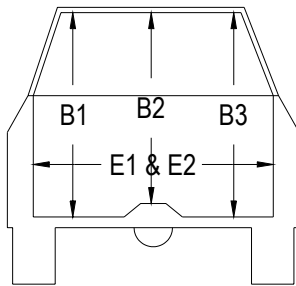

c) End view of deformation zones.

	BEFORE (mm)	AFTER (mm)
A1	870	873
A2	882	872
A3	910	875
B1	1072	1054
B2	1073	1176
B3	1071	1105
C1	1374	1380
C2	1262	1200
C3	1368	1280
D1	325	375
D2	163	143
D3	318	365
E1	1580	1590
E2	1590	1635
F	1460	1440
G	1460	1465
H	900	875
I	900	900
J*	1528	1445

\*J = Lateral measurement across cab floor from kickpanel to kickpanel.

Figure 172. Occupant compartment measurements for test 405181-12.

DATE: 06/04/03 TEST NO.: 405181-21 VIN NO.: 1GCGC24R3WZ166138  
 YEAR: 1998 MAKE: Chevrolet MODEL: Cheyenne 2500 P/U  
 TIRE INFLATION PRESSURE: \_\_\_\_\_ ODOMETER: 201248 TIRE SIZE: 245 75R16

MASS DISTRIBUTION (kg) LF 603 RF 589 LR 426 RR 467

DESCRIBE ANY DAMAGE TO VEHICLE PRIOR TO TEST:

---

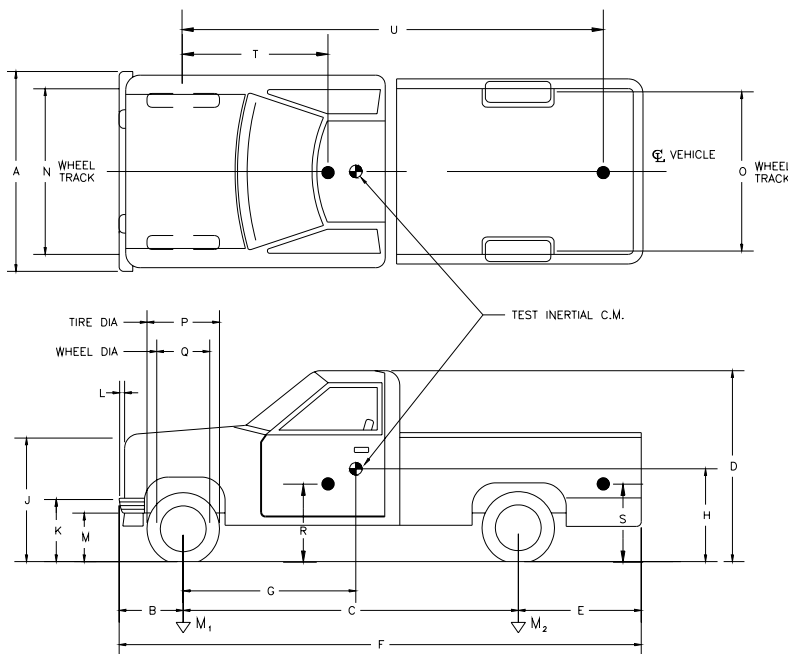

● Denotes accelerometer location.

NOTES: \_\_\_\_\_  
 \_\_\_\_\_  
 \_\_\_\_\_

ENGINE TYPE: V-8

ENGINE CID: 5.7 L

TRANSMISSION TYPE:

AUTO  
 MANUAL

OPTIONAL EQUIPMENT:

8 LUGS

DUMMY DATA:

TYPE: 50th percentile male

MASS: 77 kg

SEAT POSITION: driver

GEOMETRY - (mm)

A	<u>1880</u>	E	<u>1310</u>	J	<u>1038</u>	N	<u>1590</u>	R	<u>750</u>
B	<u>810</u>	F	<u>5470</u>	K	<u>635</u>	O	<u>1610</u>	S	<u>900</u>
C	<u>3350</u>	G	<u>1434.8</u>	L	<u>70</u>	P	<u>725</u>	T	<u>1460</u>
D	<u>1850</u>	H	<u>---</u>	M	<u>415</u>	Q	<u>440</u>	U	<u>3360</u>

MASS - (kg)	CURB	TEST INERTIAL	GROSS STATIC
M <sub>1</sub>	<u>1238</u>	<u>1192</u>	<u>1235</u>
M <sub>2</sub>	<u>907</u>	<u>893</u>	<u>927</u>
M <sub>T</sub>	<u>2145</u>	<u>2085</u>	<u>2162</u>

Figure 173. Vehicle properties for test 405181-21.

Table 34. Exterior crush measurements for test 405181-21.

VEHICLE CRUSH MEASUREMENT SHEET<sup>1</sup>

Complete When Applicable	
End Damage	Side Damage
Undeformed end width _____	Bowing: B1 ____ X1 ____
Corner shift: A1 _____	B2 ____ X2 ____
A2 _____	
End shift at frame (CDC) (check one)	Bowing constant
< 102 mm _____	$\frac{X1 + X2}{2} =$ _____
≥ 102 mm _____	

Note: Measure C1 to C6 from driver to passenger side in front or rear impacts—rear to front in side impacts.  
All measurements in millimeters.

Specific Impact Number	Plane* of C Measurements	Direct Damage		Field L**	C <sub>1</sub>	C <sub>2</sub>	C <sub>3</sub>	C <sub>4</sub>	C <sub>5</sub>	C <sub>6</sub>	±D
		Width ** (CDC)	Max*** Crush								
1	At front bumper	920	500	600	500	300	250	140	100	0	-300
2	Left side -- above level of front bumper	920	530	1480	60	115	Wheel Well		400	530	+1640

<sup>1</sup>Table taken from NASS.

\*Identify the plane at which the C measurements are taken (e.g., at bumper, above bumper, at sill, above sill, at beltline, etc.) or label adjustments (e.g., free space).

Free space value is defined as the distance between the baseline and the original body contour taken at the individual C locations. This may include the following: bumper lead, bumper taper, side protrusion, side taper, etc. Record the value for each C measurement and maximum crush.

\*\*Measure and document on the vehicle diagram the beginning or end of the direct damage width and field L (e.g., side damage with respect to undamaged axle).

\*\*\*Measure and document on the vehicle diagram the location of the maximum crush.

Note: Use as many lines/columns as necessary to describe each damage profile.



# Truck

## Occupant Compartment Deformation

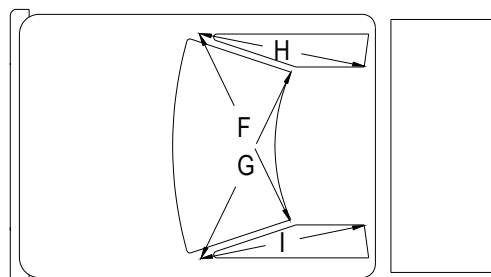

a) Top view of deformation zones.

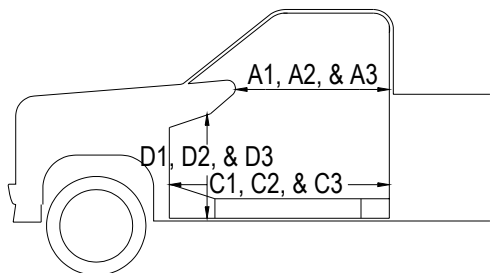

b) Side view of deformation zones.

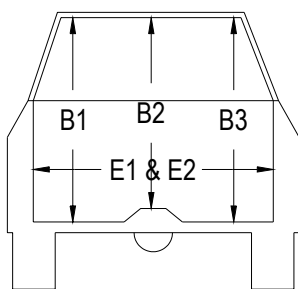

c) End view of deformation zones.

	BEFORE (mm)	AFTER (mm)
A1	870	860
A2	931	931
A3	935	935
B1	1078	1059
B2	1008	961
B3	1078	1078
C1	1373	1361
C2	---	---
C3	1371	1371
D1	323	280
D2	155	140
D3	310	315
E1	1585	1618
E2	1590	1625
F	1470	1470
G	1470	1470
H	1250	1240
I	1250	1250
J*	1521	1455

\*J = Lateral measurement across cab floor from kickpanel to kickpanel.

Figure 174. Occupant compartment measurements for test 405181-21.

DATE: 08/28/00 TEST NO.: 405181-5a VIN NO.: 1GCFC24K9SZ259853  
 YEAR: 1995 MAKE: Chevrolet MODEL: 2500 Pickup Truck  
 TIRE INFLATION PRESSURE: \_\_\_\_\_ ODOMETER: 208527 TIRE SIZE: LT 225 75R16

MASS DISTRIBUTION (kg) LF 571 RF 546 LR 442 RR 441

DESCRIBE ANY DAMAGE TO VEHICLE PRIOR TO TEST:

---

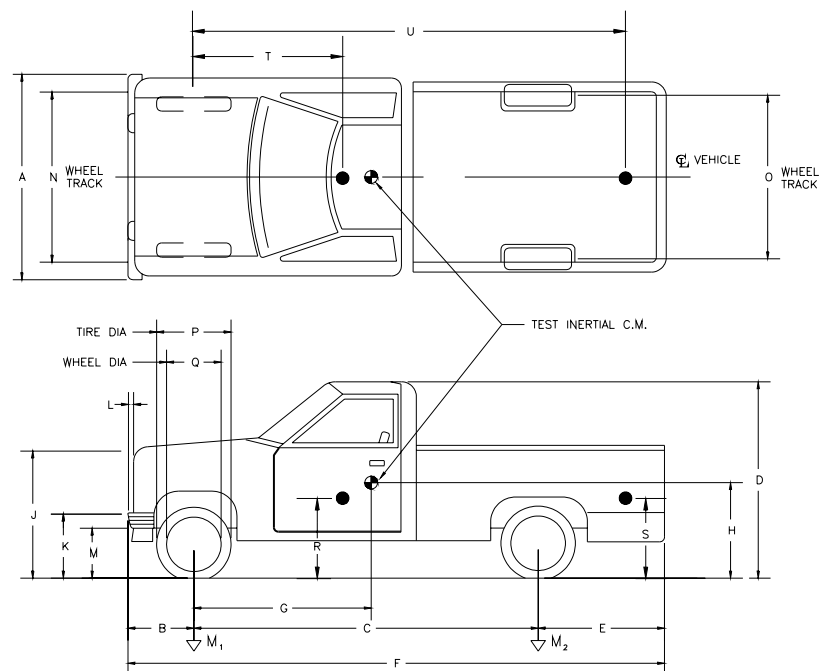

● Denotes accelerometer location.

NOTES: \_\_\_\_\_  
 \_\_\_\_\_

ENGINE TYPE: 8 CYL

ENGINE CID: 5.7L

TRANSMISSION TYPE:

AUTO  
 MANUAL

OPTIONAL EQUIPMENT:

6 LUGS

DUMMY DATA:

TYPE: 50th percentile male

MASS: 76 kg

SEAT POSITION: Driver

GEOMETRY - (mm)

A	<u>1880</u>	E	<u>1310</u>	J	<u>1020</u>	N	<u>1600</u>	R	<u>670</u>
B	<u>840</u>	F	<u>5500</u>	K	<u>605</u>	O	<u>1615</u>	S	<u>830</u>
C	<u>3350</u>	G	<u>---</u>	L	<u>70</u>	P	<u>730</u>	T	<u>1450</u>
D	<u>1800</u>	H	<u>---</u>	M	<u>395</u>	Q	<u>445</u>	U	<u>3350</u>

<u>MASS - (kg)</u>	<u>CURB</u>	<u>TEST INERTIAL</u>	<u>GROSS STATIC</u>
M <sub>1</sub>	<u>1120</u>	<u>1117</u>	<u>1170</u>
M <sub>2</sub>	<u>780</u>	<u>883</u>	<u>904</u>
M <sub>T</sub>	<u>1890</u>	<u>2000</u>	<u>2074</u>

Figure 175. Vehicle properties for test 405181-5a.

Table 35. Exterior crush measurements for test 405181-5a.

VEHICLE CRUSH MEASUREMENT SHEET<sup>1</sup>

Complete When Applicable	
End Damage	Side Damage
Undeformed end width _____  Corner shift: A1 _____ A2 _____  End shift at frame (CDC) (check one) < 102 mm _____ ≥ 102 mm _____	Bowing: B1 ____ X1 ____  B2 ____ X2 ____   Bowing constant  $\frac{X1 + X2}{2} = \underline{\hspace{2cm}}$

Note: Measure C1 to C6 from driver to passenger side in front or rear impacts—rear to front in side impacts.  
All measurements in millimeters.

Specific Impact Number	Plane* of C Measurements	Direct Damage		Field L**	C <sub>1</sub>	C <sub>2</sub>	C <sub>3</sub>	C <sub>4</sub>	C <sub>5</sub>	C <sub>6</sub>	±D
		Width ** (CDC)	Max*** Crush								
1	At front bumper	1050	550	1510	+50	-30	-85	-190	-380	-550	0
2	Left side – 700 mm above ground	1050	540	1140	-140	-210	N/A	N/A	-415	-540	+1490

<sup>1</sup>Table taken from NASS.

\*Identify the plane at which the C measurements are taken (e.g., at bumper, above bumper, at sill, above sill, at beltline, etc.) or label adjustments (e.g., free space).

Free space value is defined as the distance between the baseline and the original body contour taken at the individual C locations. This may include the following: bumper lead, bumper taper, side protrusion, side taper, etc. Record the value for each C measurement and maximum crush.

\*\*Measure and document on the vehicle diagram the beginning or end of the direct damage width and field L (e.g., side damage with respect to undamaged axle).

\*\*\*Measure and document on the vehicle diagram the location of the maximum crush.

Note: Use as many lines/columns as necessary to describe each damage profile.

# Truck

## Occupant Compartment Deformation

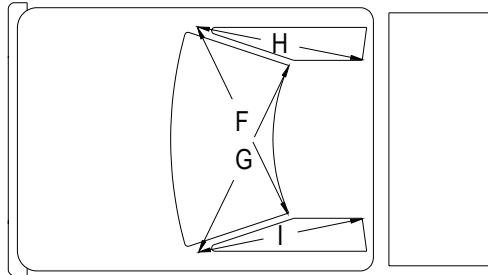

a) Top view of deformation zones.

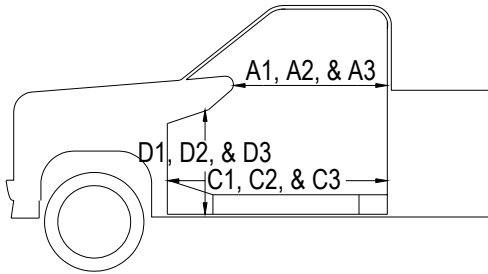

b) Side view of deformation zones.

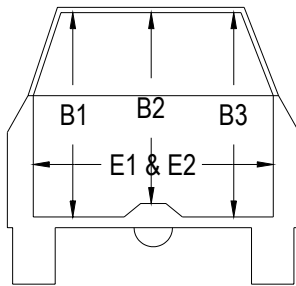

c) End view of deformation zones.

	BEFORE (mm)	AFTER (mm)
A1	965	965
A2	941	924
A3	945	890
B1	1108	1108
B2	1061	1071
B3	1111	1091
C1	1375	1375
C2	1372	1351
C3	1400	1275
D1	330	330
D2	162	186
D3	307	410
E1	1597	1625
E2	1592	1630
F	1470	1480
G	1470	1470
H	1000	970
I	1000	1000
J*	1531	1425

\*J = Lateral measurement across cab floor from kickpanel to kickpanel.

Figure 176. Occupant compartment measurements for test 405181-5a.

DATE: 03/25/03 TEST NO.: 405181-18 VIN NO.: 1GCGC24R7WZ130596  
 YEAR: 1998 MAKE: Chevrolet MODEL: 2500 Pickup  
 TIRE INFLATION PRESSURE: \_\_\_\_\_ ODOMETER: 153061 TIRE SIZE: 245 75R15

MASS DISTRIBUTION (kg) LF 599 RF 594 LR 449 RR 449

DESCRIBE ANY DAMAGE TO VEHICLE PRIOR TO TEST:  
 \_\_\_\_\_  
 \_\_\_\_\_

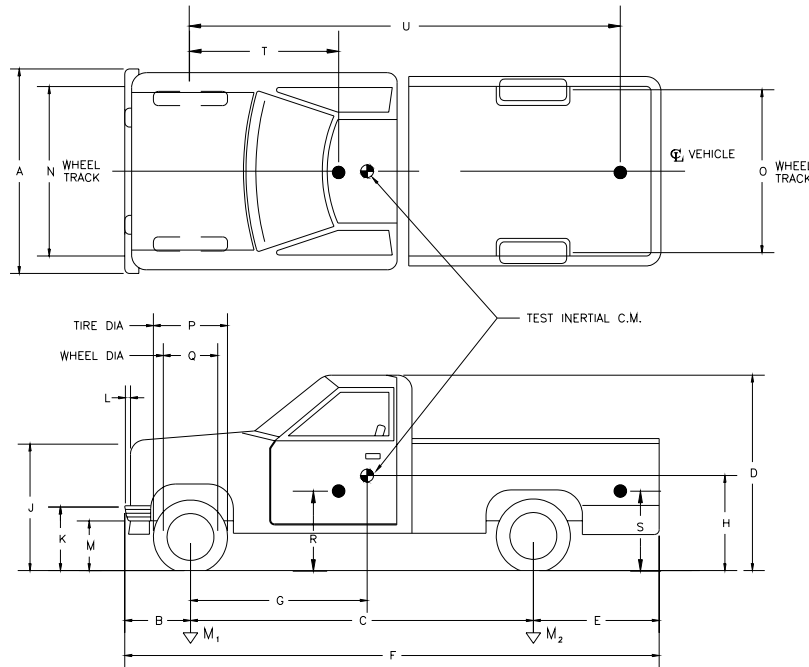

● Denotes accelerometer location.

NOTES: \_\_\_\_\_  
 \_\_\_\_\_

ENGINE TYPE: 8 CYL  
 ENGINE CID: 5.7 L

TRANSMISSION TYPE:  
 AUTO  
 MANUAL

OPTIONAL EQUIPMENT:  
8 LUGS  
 \_\_\_\_\_  
 \_\_\_\_\_

DUMMY DATA:  
 TYPE: 50th percentile male  
 MASS: 76 kg  
 SEAT POSITION: passenger

GEOMETRY - (mm)

A	<u>1880</u>	E	<u>1310</u>	J	<u>1038</u>	N	<u>1590</u>	R	<u>750</u>
B	<u>810</u>	F	<u>5470</u>	K	<u>635</u>	O	<u>1610</u>	S	<u>900</u>
C	<u>3350</u>	G	<u>1438.7</u>	L	<u>70</u>	P	<u>725</u>	T	<u>1460</u>
D	<u>1820</u>	H	<u>---</u>	M	<u>415</u>	Q	<u>440</u>	U	<u>3360</u>

MASS - (kg)	CURB	TEST INERTIAL	GROSS STATIC
M <sub>1</sub>	<u>1251</u>	<u>1193</u>	<u>1242</u>
M <sub>2</sub>	<u>870</u>	<u>898</u>	<u>925</u>
M <sub>T</sub>	<u>2121</u>	<u>2091</u>	<u>2167</u>

Figure 177. Vehicle properties for test 405181-18.



# Truck

## Occupant Compartment Deformation

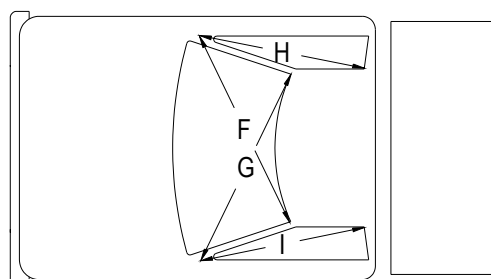

a) Top view of deformation zones.

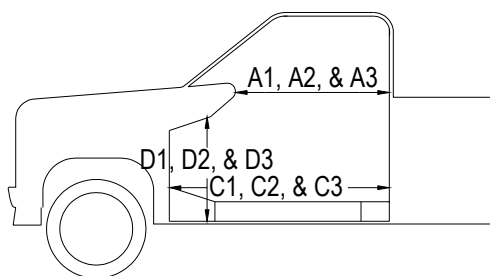

b) Side view of deformation zones.

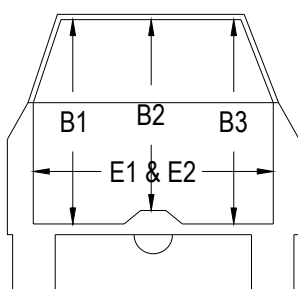

c) End view of deformation zones.

	BEFORE (mm)	AFTER (mm)
A1	866	840
A2	939	935
A3	937	948
B1	1083	1000
B2	1034	967
B3	1072	1072
C1	1371	1290
C2	---	---
C3	1375	1375
D1	322	215
D2	156	129
D3	308	270
E1	1590	1658
E2	1594	1697
F	1463	1455
G	1463	1470
H	1240	1230
I	1247	1247
J*	1523	1403

\*J = Lateral measurement across cab floor from kickpanel to kickpanel.

Figure 178. Occupant compartment measurements for test 405181-18.

DATE: 06/27/03 TEST NO.: 405181-22 VIN NO.: 1GCGC24R5WZ135263  
 YEAR: 1998 MAKE: Chevrolet MODEL: Cheyenne 2500 P/U  
 TIRE INFLATION PRESSURE: \_\_\_\_\_ ODOMETER: 186967 TIRE SIZE: 245 75R16

MASS DISTRIBUTION (kg) LF 602 RF 586 LR 435 RR 451

DESCRIBE ANY DAMAGE TO VEHICLE PRIOR TO TEST:  
 \_\_\_\_\_  
 \_\_\_\_\_

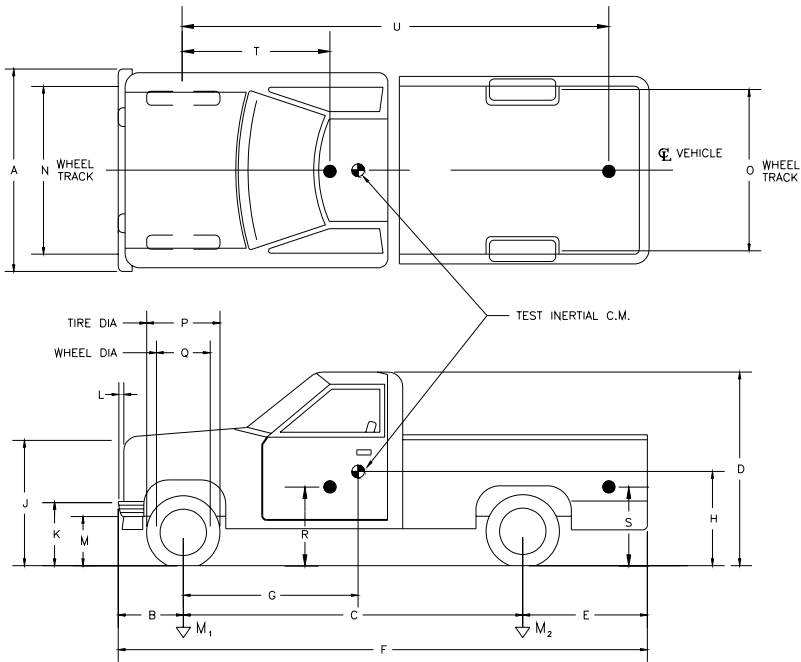

● Denotes accelerometer location.

NOTES: \_\_\_\_\_  
 \_\_\_\_\_

ENGINE TYPE: V-8

ENGINE CID: 5.7 L

TRANSMISSION TYPE:

AUTO  
 MANUAL

OPTIONAL EQUIPMENT:

8 LUGS

DUMMY DATA:

TYPE: 50th percentile male

MASS: 77 kg

SEAT POSITION: passenger

GEOMETRY - (mm)

A	<u>1880</u>	E	<u>1310</u>	J	<u>1038</u>	N	<u>1590</u>	R	<u>750</u>
B	<u>810</u>	F	<u>5470</u>	K	<u>635</u>	O	<u>1610</u>	S	<u>900</u>
C	<u>3350</u>	G	<u>1431.1</u>	L	<u>70</u>	P	<u>725</u>	T	<u>1460</u>
D	<u>1820</u>	H	<u>---</u>	M	<u>415</u>	Q	<u>440</u>	U	<u>3360</u>

MASS - (kg)	CURB	TEST INERTIAL	GROSS STATIC
M <sub>1</sub>	<u>1228</u>	<u>1188</u>	<u>1227</u>
M <sub>2</sub>	<u>928</u>	<u>886</u>	<u>924</u>
M <sub>T</sub>	<u>2156</u>	<u>2074</u>	<u>2151</u>

Figure 179. Vehicle properties for test 405181-22.



Table 37. Exterior crush measurements for test 405181-22.

VEHICLE CRUSH MEASUREMENT SHEET<sup>1</sup>

Complete When Applicable	
End Damage	Side Damage
Undeformed end width _____  Corner shift: A1 _____ A2 _____  End shift at frame (CDC) (check one) < 102 mm _____ ≥ 102 mm _____	Bowing: B1 ____ X1 ____  B2 ____ X2 ____   Bowing constant  $\frac{X1 + X2}{2} = \underline{\hspace{2cm}}$

Note: Measure C1 to C6 from driver to passenger side in front or rear impacts—rear to front in side impacts.  
All measurements in millimeters.

Specific Impact Number	Plane* of C Measurements	Direct Damage		Field L**	C <sub>1</sub>	C <sub>2</sub>	C <sub>3</sub>	C <sub>4</sub>	C <sub>5</sub>	C <sub>6</sub>	±D
		Width ** (CDC)	Max*** Crush								
1	At front bumper	1100	640	600	0	140	270	370	490	640	-300
2	Right side -- at level of front bumper	1100	750	1320	120	240	N/A	460	630	750	+1670

<sup>1</sup>Table taken from NASS.

\*Identify the plane at which the C measurements are taken (e.g., at bumper, above bumper, at sill, above sill, at beltline, etc.) or label adjustments (e.g., free space).

Free space value is defined as the distance between the baseline and the original body contour taken at the individual C locations. This may include the following: bumper lead, bumper taper, side protrusion, side taper, etc. Record the value for each C measurement and maximum crush.

\*\*Measure and document on the vehicle diagram the beginning or end of the direct damage width and field L (e.g., side damage with respect to undamaged axle).

\*\*\*Measure and document on the vehicle diagram the location of the maximum crush.

Note: Use as many lines/columns as necessary to describe each damage profile.

# Truck

## Occupant Compartment Deformation

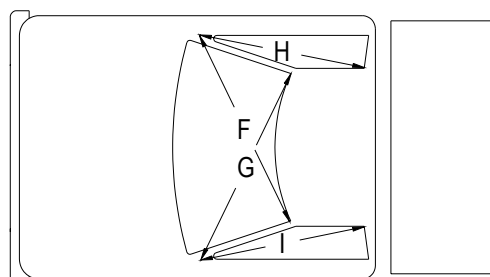

a) Top view of deformation zones.

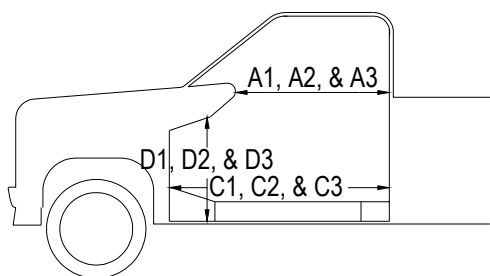

b) Side view of deformation zones.

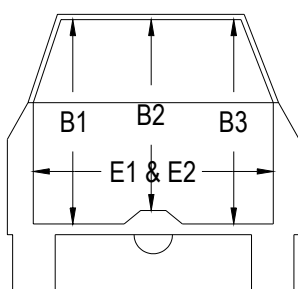

c) End view of deformation zones.

	BEFORE (mm)	AFTER (mm)
A1	870	840
A2	935	930
A3	935	930
B1	1078	1059
B2	1071	970
B3	1067	1005
C1	1366	1366
C2	---	---
C3	1373	1345
D1	325	320
D2	161	133
D3	308	230
E1	1590	1610
E2	1595	1636
F	1475	1460
G	1475	1455
H	1250	1230
I	1260	1245
J*	1522	1375

\*J = Lateral measurement across cab floor from kickpanel to kickpanel.

Figure 180. Occupant compartment measurements for test 405181-22.

## APPENDIX C. SEQUENTIAL PHOTOGRAPHS



a) Overhead at 0.000 s.



e) Overhead at 0.312 s.



b) Overhead at 0.062 s.



f) Overhead at 0.437 s.



c) Overhead at 0.125 s.



g) Overhead at 0.625 s.



d) Overhead at 0.219 s.



h) Overhead at 0.812 s.

Figure 181. Sequential photographs for test 405181-1 (overhead view).



a) Rear at 0.000 s.



e) Rear at 0.312 s.



b) Rear at 0.062 s.

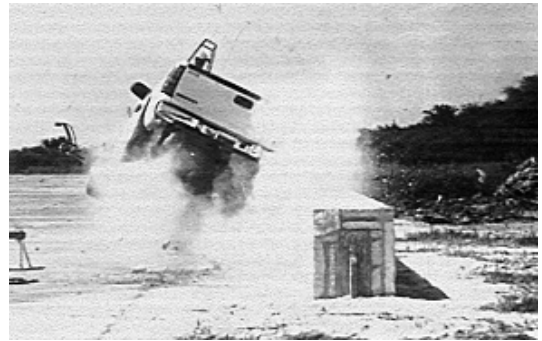

f) Rear at 0.437 s.



c) Rear at 0.125 s.



g) Rear at 0.625 s.



d) Rear at 0.219 s.



h) Rear at 0.812 s.

Figure 182. Sequential photographs for test 405181-1 (rear view).



a) Overhead at 0.000 s.



e) Overhead at 0.422 s.



b) Overhead at 0.094 s.



f) Overhead at 0.586 s.



c) Overhead at 0.188 s.



g) Overhead at 0.821 s.



d) Overhead at 0.281 s.



h) Overhead at 1.173 s.

Figure 183. Sequential photographs for test 405181-2 (overhead view).



a) Frontal at 0.000 s.



e) Frontal at 0.422 s.



b) Frontal at 0.094 s.



f) Frontal at 0.586 s.



c) Frontal at 0.188 s.



g) Frontal at 0.821 s.



d) Frontal at 0.281 s.



h) Frontal at 1.173 s.

Figure 184. Sequential photographs for test 405181-2 (frontal view).



a) Rear at 0.000 s.

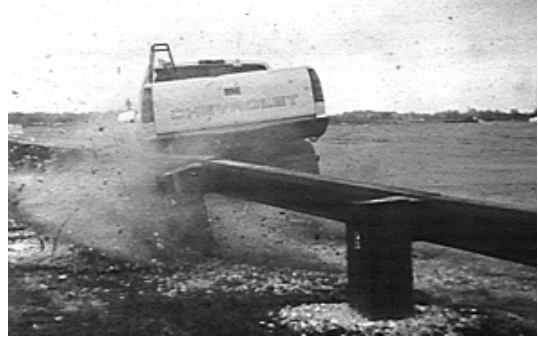

e) Rear at 0.422 s.



b) Rear at 0.094 s.



f) Rear at 0.586 s.



c) Rear at 0.188 s.



g) Rear at 0.821 s.



d) Rear at 0.281 s.

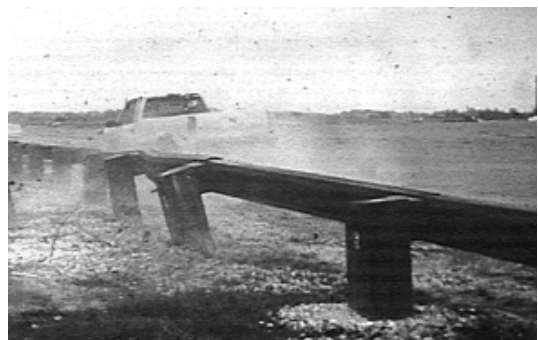

h) Rear at 1.173 s.

Figure 185. Sequential photographs for test 405181-2 (rear view).



a) Overhead at 0.000 s.



e) Overhead at 0.373 s.



b) Overhead at 0.050 s.

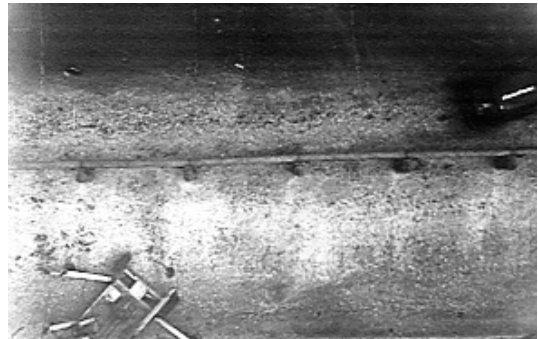

f) Overhead at 0.746 s.



c) Overhead at 0.124 s.

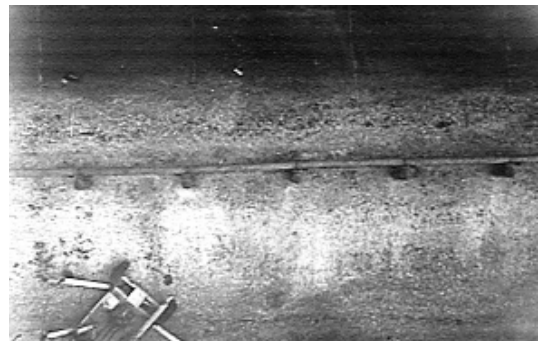

g) Overhead at 1.244 s.



d) Overhead at 0.224 s.

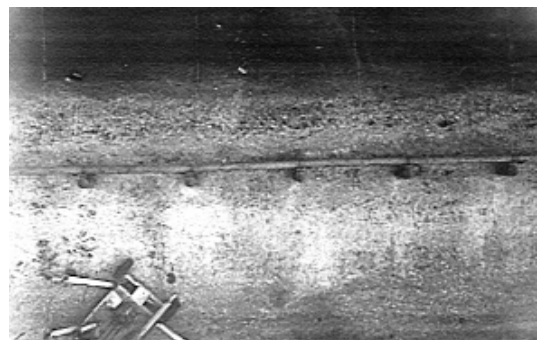

h) Overhead at 1.990 s.

Figure 186. Sequential photographs for test 405181-4 (overhead view).





a) Frontal at 0.000 s.



e) Frontal at 0.373 s.



b) Frontal at 0.050 s.



f) Frontal at 0.746 s.



c) Frontal at 0.124 s.



g) Frontal at 1.244 s.



d) Frontal at 0.224 s.



h) Frontal at 1.990 s.

Figure 187. Sequential photographs for test 405181-4 (frontal view).



a) Rear at 0.000 s.



e) Rear at 0.373 s.

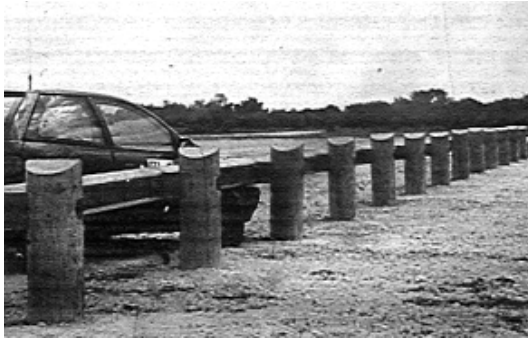

b) Rear at 0.050 s.

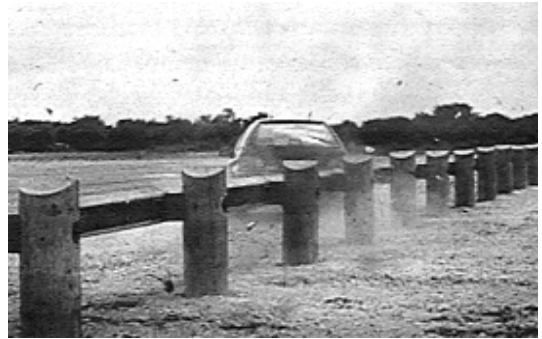

f) Rear at 0.746 s.



c) Rear at 0.124 s.



g) Rear at 1.244 s.



d) Rear at 0.224 s.



h) Rear at 1.990 s.

Figure 188. Sequential photographs for test 405181-4 (rear view).



a) Overhead at 0.000 s.



e) Overhead at 0.421 s.



b) Overhead at 0.074 s.

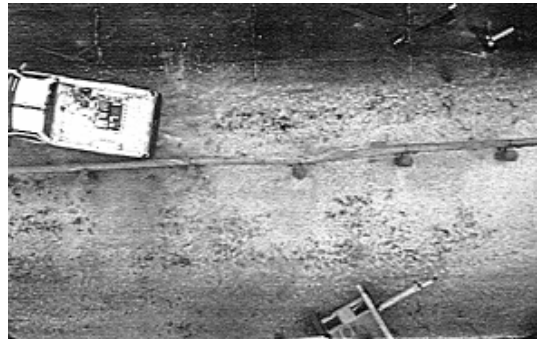

f) Overhead at 0.742 s.



c) Overhead at 0.148 s.

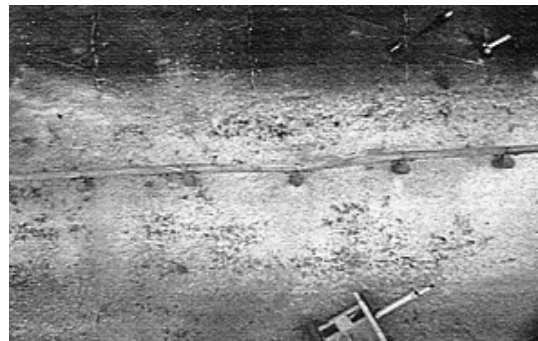

g) Overhead at 1.114 s.



d) Overhead at 0.247 s.



h) Overhead at 1.732 s.

Figure 189. Sequential photographs for test 405181-3 (overhead view).

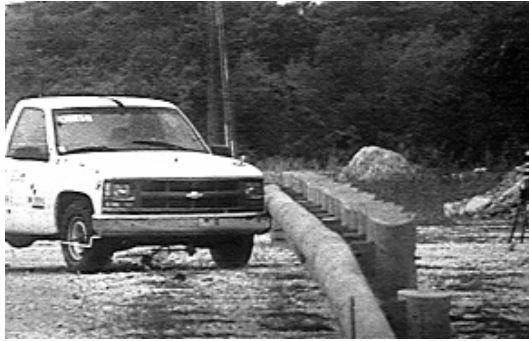

a) Frontal at 0.000 s.



e) Frontal at 0.421 s.

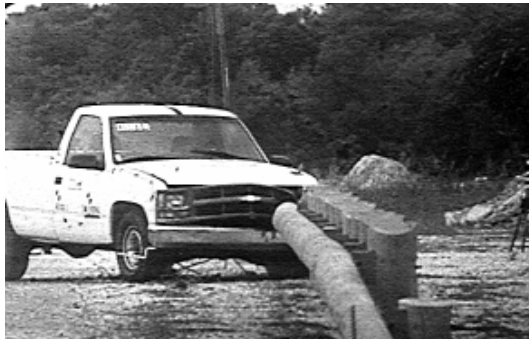

b) Frontal at 0.074 s.



f) Frontal at 0.742 s.



c) Frontal at 0.148 s.

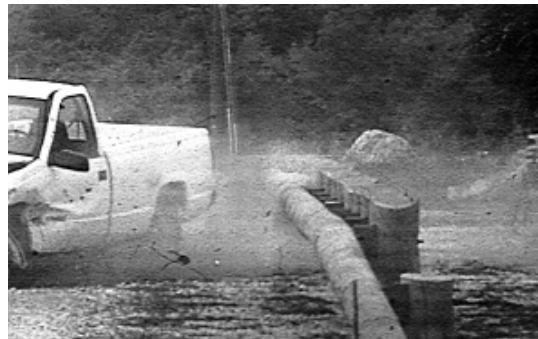

g) Frontal at 1.114 s.



d) Frontal at 0.247 s.

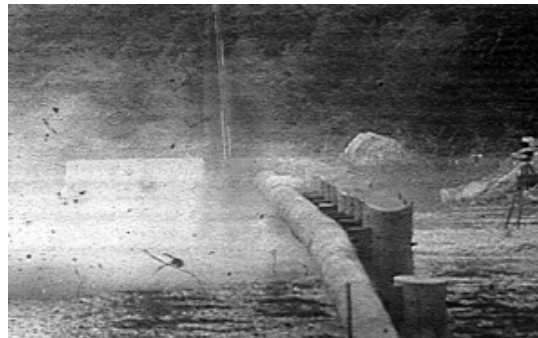

h) Frontal at 1.732 s.

Figure 190. Sequential photographs for test 405181-3 (frontal view).



a) Rear at 0.000 s.



e) Rear at 0.421 s.



b) Rear at 0.074 s.



f) Rear at 0.742 s.



c) Rear at 0.148 s.

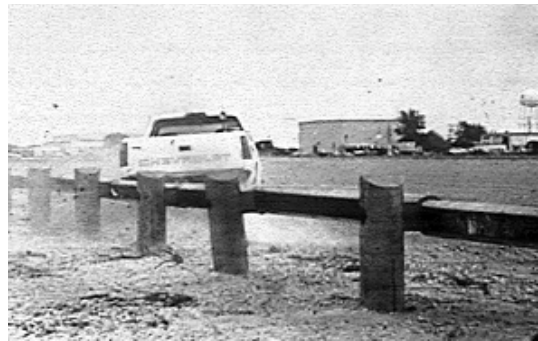

g) Rear at 1.114 s.



d) Rear at 0.247 s.

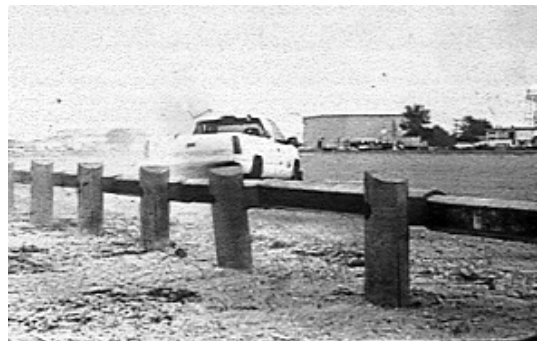

h) Rear at 1.732 s.

Figure 191. Sequential photographs for test 405181-3 (rear view).

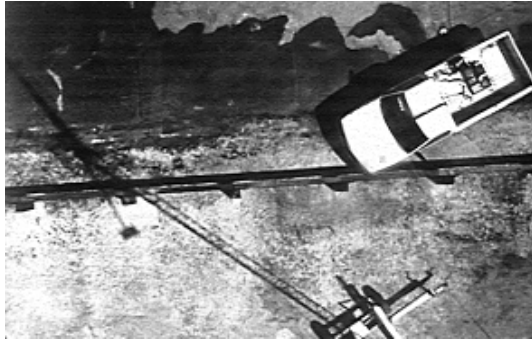

a) Overhead at 0.000 s.

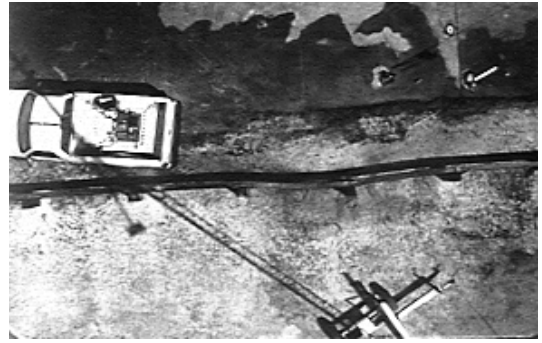

e) Overhead at 0.744 s.



b) Overhead at 0.099 s.



f) Overhead at 1.240 s.



c) Overhead at 0.198 s.

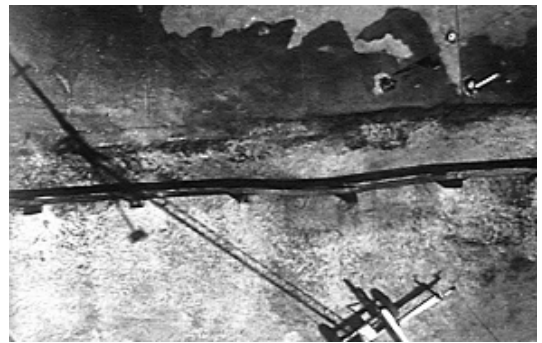

g) Overhead at 1.736 s.



d) Overhead at 0.397 s.



h) Overhead at 3.968 s.

Figure 192. Sequential photographs for test 405181-13 (overhead view).



a) Frontal at 0.000 s.



e) Frontal at 0.744 s.



b) Frontal at 0.099 s.



f) Frontal at 1.240 s.



c) Frontal at 0.198 s.



g) Frontal at 1.736 s.



d) Frontal at 0.397 s.



h) Frontal at 3.968 s.

Figure 193. Sequential photographs for test 405181-13 (frontal view).



a) Rear at 0.000 s.



e) Rear at 0.744 s.



b) Rear at 0.099 s.



f) Rear at 1.240 s.



c) Rear at 0.198 s.



g) Rear at 1.736 s.



d) Rear at 0.397 s.



h) Rear at 3.968 s.

Figure 194. Sequential photographs for test 405181-13 (rear view).



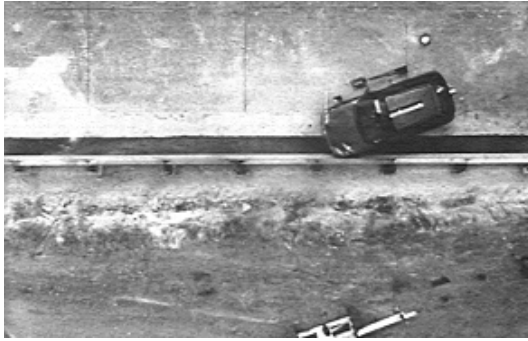

a) Overhead at 0.000 s.

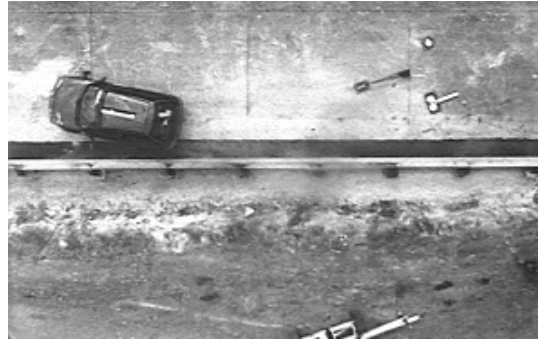

e) Overhead at 0.737 s.



b) Overhead at 0.123 s.

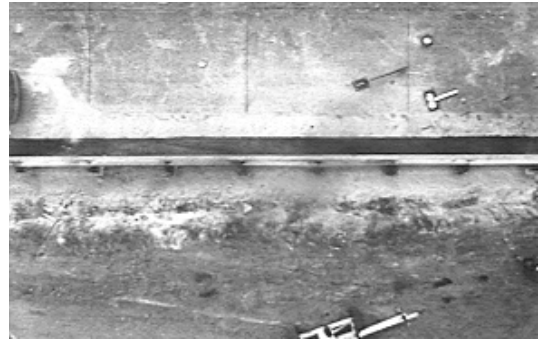

f) Overhead at 1.229 s.



c) Overhead at 0.246 s.

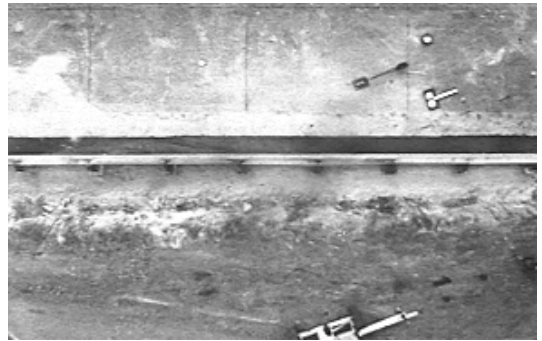

g) Overhead at 1.794 s.



d) Overhead at 0.442 s.

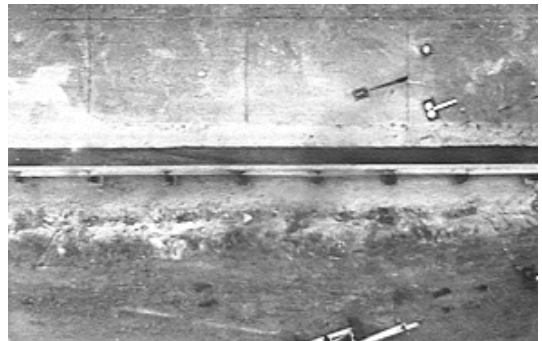

h) Overhead at 3.441 s.

Figure 195. Sequential photographs for test 405181-14 (overhead view).



a) Frontal at 0.000 s.



e) Frontal at 0.737 s.



b) Frontal at 0.123 s.



f) Frontal at 1.229 s.



c) Frontal at 0.246 s.



g) Frontal at 1.794 s.



d) Frontal at 0.442 s.



h) Frontal at 3.441 s.

Figure 196. Sequential photographs for test 405181-14 (frontal view).



a) Rear at 0.000 s.



e) Rear at 0.737 s.



b) Rear at 0.123 s.



f) Rear at 1.229 s.



c) Rear at 0.246 s.



g) Rear at 1.794 s.



d) Rear at 0.442 s.



h) Rear at 3.441 s.

Figure 197. Sequential photographs for test 405181-14 (rear view).



a) Overhead at 0.000 s.

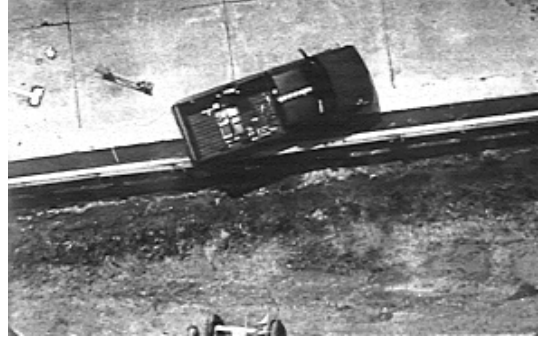

e) Overhead at 0.542 s.

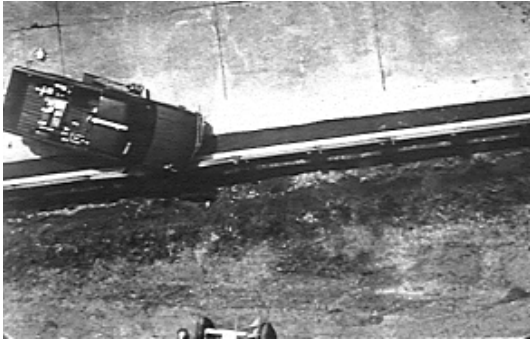

b) Overhead at 0.099 s.

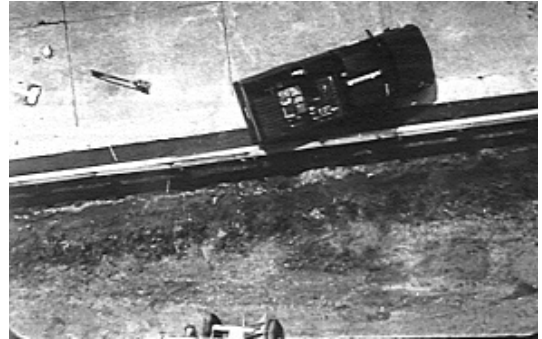

f) Overhead at 0.739 s.

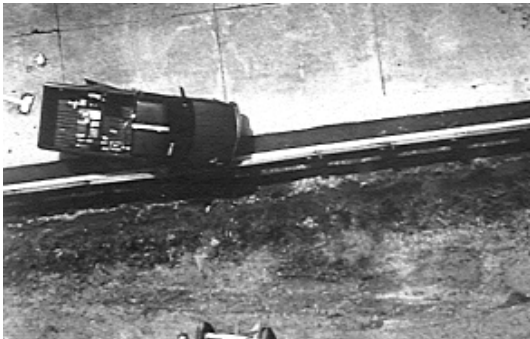

c) Overhead at 0.197 s.

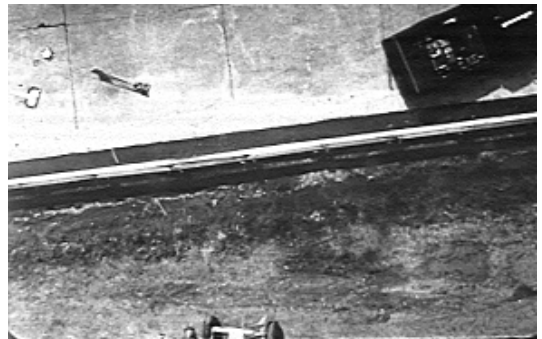

g) Overhead at 1.232 s.

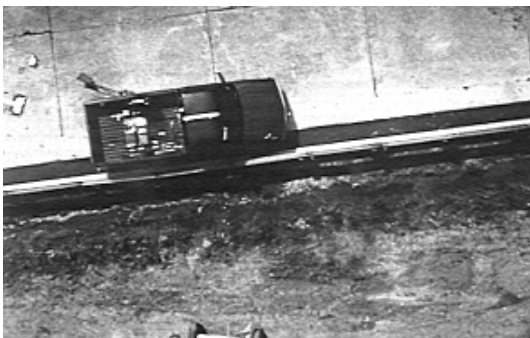

d) Overhead 0.345 s.

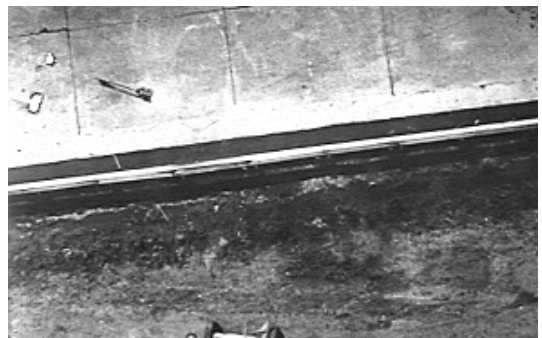

h) Overhead at 2.095 s.

Figure 198. Sequential photographs for test 405181-15 (overhead view).



a) Frontal at 0.000 s.



e) Frontal at 0.542 s.



b) Frontal at 0.099 s.



f) Frontal at 0.739 s.



c) Frontal at 0.197 s.



g) Frontal at 1.232 s.



d) Frontal at 0.345 s.



h) Frontal at 2.095 s.

Figure 199. Sequential photographs for test 405181-15 (frontal view).



a) Rear at 0.000 s.



e) Rear at 0.542 s.



b) Rear at 0.099 s.



f) Rear at 0.739 s.



c) Rear at 0.197 s.



g) Rear at 1.232 s.



d) Rear at 0.345 s.



h) Rear at 2.095 s.

Figure 200. Sequential photographs for test 405181-15 (rear view).



a) Overhead at 0.000 s.



e) Overhead at 0.381 s.



b) Overhead at 0.048 s.



f) Overhead at 0.731 s.



c) Overhead at 0.095 s.



g) Overhead at 1.427 s.



d) Overhead at 0.190 s.



h) Overhead at 2.140 s.

Figure 201. Sequential photographs for test 405181-19 (overhead view).



a) Frontal at 0.000 s.



e) Frontal at 0.381 s.



b) Frontal at 0.048 s.



f) Frontal at 0.713 s.



c) Frontal at 0.095 s.



g) Frontal at 1.427 s.



d) Frontal at 0.190 s.



h) Frontal at 2.140 s.

Figure 202. Sequential photographs for test 405181-19 (frontal view).





a) Rear at 0.000 s.



e) Rear at 0.381 s.



b) Rear at 0.048 s.



f) Rear at 0.713 s.



c) Rear at 0.095 s.



g) Rear at 1.427 s.



d) Rear at 0.190 s.



h) Rear at 2.140 s.

Figure 203. Sequential photographs for test 405181-19 (rear view).

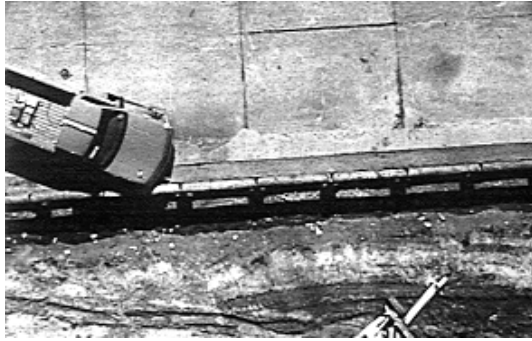

a) Overhead at 0.000 s.



e) Overhead at 0.726 s.



b) Overhead at 0.097 s.



f) Overhead at 1.210 s.

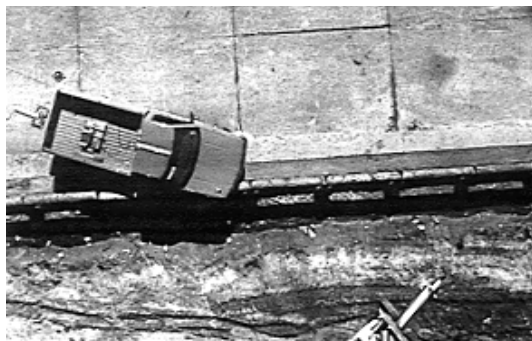

c) Overhead at 0.194 s.

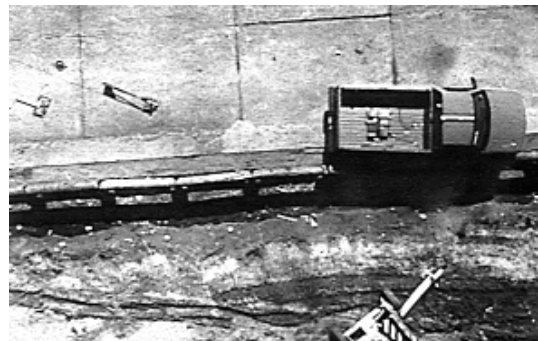

g) Overhead at 1.936 s.



d) Overhead at 0.363 s.

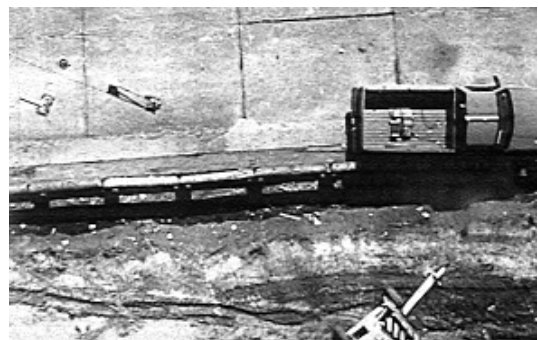

h) Overhead at 2.904 s.

Figure 204. Sequential photographs for test 405181-20 (overhead view).



a) Frontal at 0.000 s.



e) Frontal at 0.726 s.



b) Frontal at 0.097 s.



f) Frontal at 1.210 s.



c) Frontal at 0.194 s.



g) Frontal at 1.936 s.



d) Frontal at 0.363 s.



h) Frontal at 2.904 s.

Figure 205. Sequential photographs for test 405181-20 (frontal view).



a) Rear at 0.000 s.

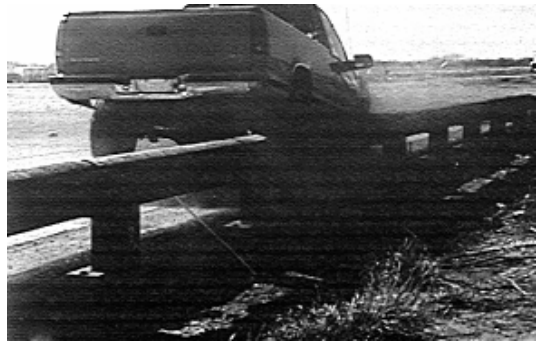

e) Rear at 0.726 s.



b) Rear at 0.097 s.



f) Rear at 1.210 s.



c) Rear at 0.194 s.



g) Rear at 1.936 s.



d) Rear at 0.363 s.



h) Rear at 2.904 s.

Figure 206. Sequential photographs for test 405181-20 (rear view).



a) Overhead at 0.000 s.

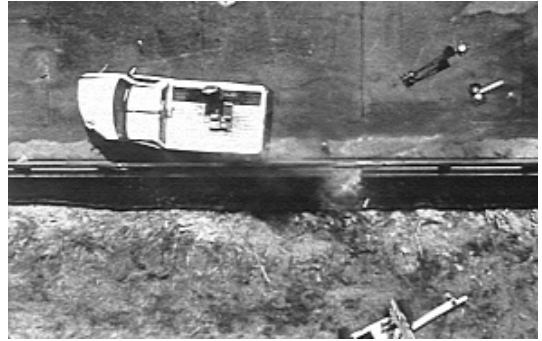

e) Overhead at 0.370 s.



b) Overhead at 0.074 s.

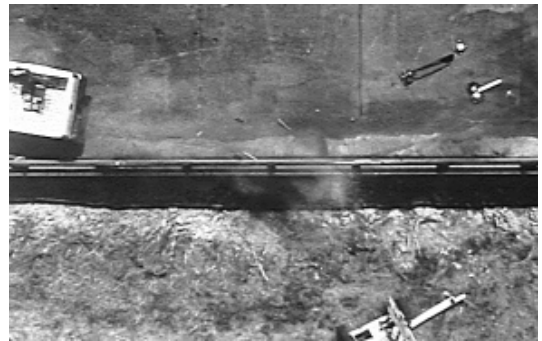

f) Overhead at 0.616 s.



c) Overhead at 0.148 s.

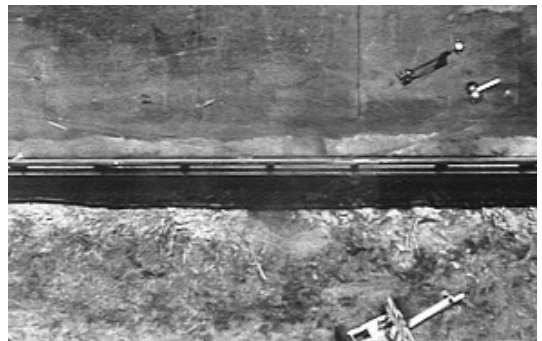

g) Overhead at 0.986 s.



d) Overhead at 0.246 s.

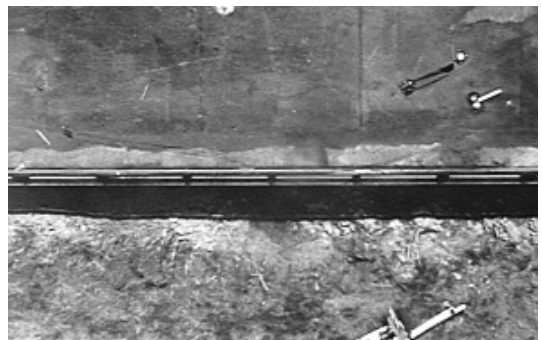

h) Overhead at 1.602 s.

Figure 207. Sequential photographs for test 405181-9 (overhead view).



a) Frontal at 0.000 s.



e) Frontal at 0.370 s.



b) Frontal at 0.074 s.



f) Frontal at 0.616 s.



c) Frontal at 0.148 s.



g) Frontal at 0.986 s.



d) Frontal at 0.246 s.



h) Frontal at 1.602 s.

Figure 208. Sequential photographs for test 405181-9 (frontal view).



a) Rear at 0.000 s.

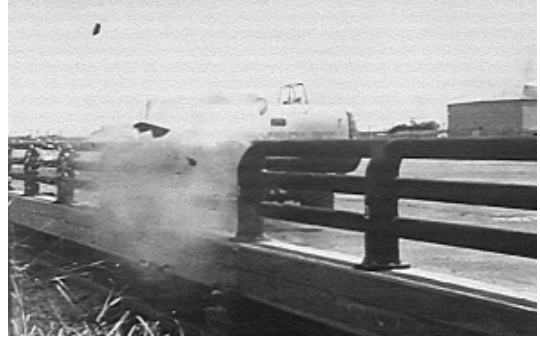

e) Rear at 0.370 s.



b) Rear at 0.074 s.



f) Rear at 0.616 s.



c) Rear at 0.148 s.



g) Rear at 0.986 s.



d) Rear at 0.246 s.



h) Rear at 1.602 s.

Figure 209. Sequential photographs for test 405181-9 (rear view).



a) Overhead at 0.000 s.



e) Overhead at 0.482 s.



b) Overhead at 0.072 s.



f) Overhead at 0.723 s.



c) Overhead at 0.169 s.



g) Overhead at 1.084 s.



d) Overhead at 0.289 s.



h) Overhead at 1.566 s.

Figure 210. Sequential photographs for test 405181-11 (overhead view).





a) Frontal at 0.000 s.



e) Frontal at 0.482 s.



b) Frontal at 0.072 s.



f) Frontal at 0.723 s.



c) Frontal at 0.169 s.



g) Frontal at 1.084 s.



d) Frontal at 0.289 s.



h) Frontal at 1.566 s.

Figure 211. Sequential photographs for test 405181-11 (frontal view).



a) Rear at 0.000 s.



e) Rear at 0.482 s.



b) Rear at 0.072 s.



f) Rear at 0.723 s.



c) Rear at 0.169 s.



g) Rear at 1.084 s.



d) Rear at 0.289 s.



h) Rear at 1.566 s.

Figure 212. Sequential photographs for test 405181-11 (rear view).



a) Overhead at 0.000 s.



e) Overhead at 0.296 s.



b) Overhead at 0.049 s.



f) Overhead at 0.494 s.



c) Overhead at 0.099 s.



g) Overhead at 0.864 s.



d) Overhead at 0.197 s.



h) Overhead at 2.962 s.

Figure 213. Sequential photographs for test 405181-12 (overhead view).



a) Frontal at 0.000 s.



e) Frontal at 0.296 s.



b) Frontal at 0.049 s.



f) Frontal at 0.494 s.



c) Frontal at 0.099 s.



g) Frontal at 0.864 s.



d) Frontal at 0.197 s.



h) Frontal at 2.962 s.

Figure 214. Sequential photographs for test 405181-12 (frontal view).

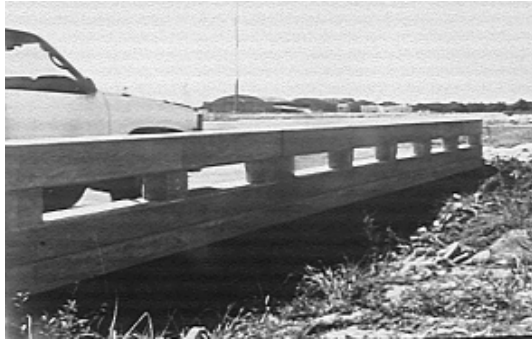

a) Rear at 0.000 s.



e) Rear at 0.296 s.



b) Rear at 0.049 s.



f) Rear at 0.494 s.



c) Rear at 0.099 s.



g) Rear at 0.864 s.



d) Rear at 0.197 s.



h) Rear at 2.962 s.

Figure 215. Sequential photographs for test 405181-12 (rear view).



a) Overhead at 0.000 s.



e) Overhead at 0.496 s.



b) Overhead at 0.099 s.

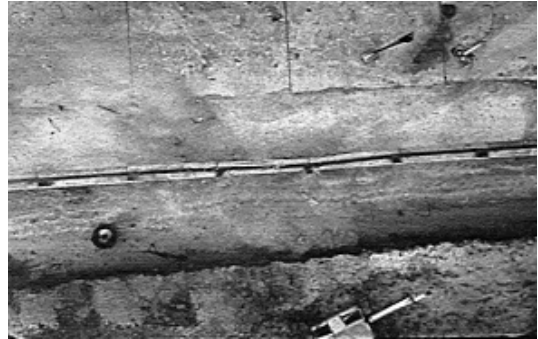

f) Overhead at 0.743 s.



c) Overhead at 0.198 s.

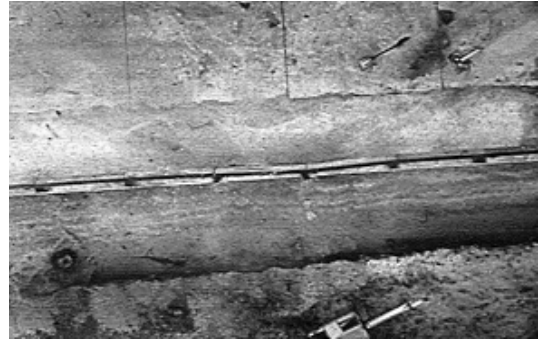

g) Overhead at 1.115 s.



d) Overhead at 0.297 s.

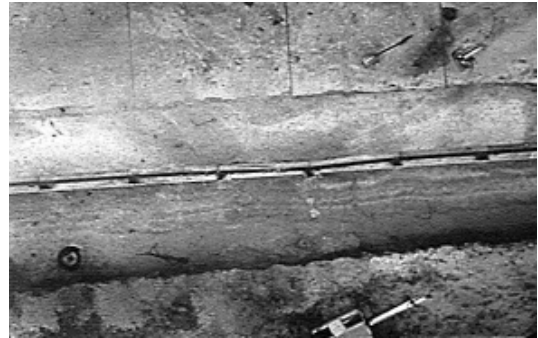

h) Overhead at 1.610 s.

Figure 216. Sequential photographs for test 405181-21 (overhead view).



a) Frontal at 0.000 s.



e) Frontal at 0.496 s.



b) Frontal at 0.099 s.



f) Frontal at 0.743 s.



c) Frontal at 0.198 s.



g) Frontal at 1.115 s.



d) Frontal at 0.297 s.



h) Frontal at 1.610 s.

Figure 217. Sequential photographs for test 405181-21 (frontal view).



a) Rear at 0.000 s.



e) Rear at 0.496 s.



b) Rear at 0.099 s.

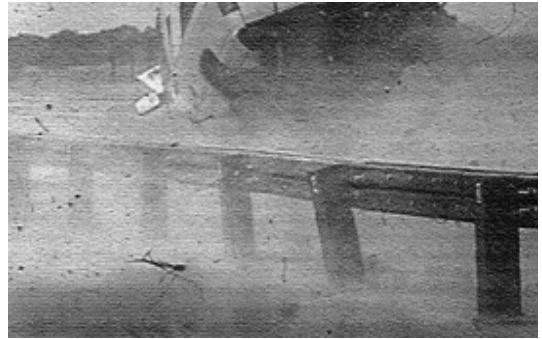

f) Rear at 0.743 s.



c) Rear at 0.198 s.

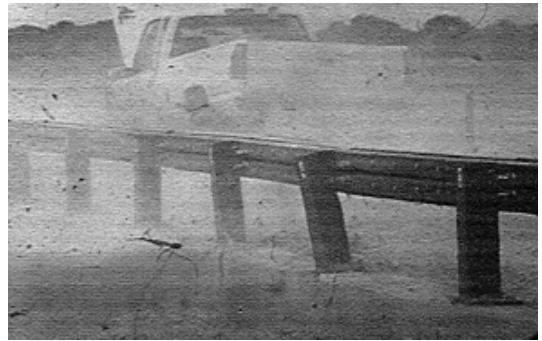

g) Rear at 1.115 s.



d) Rear at 0.297 s.

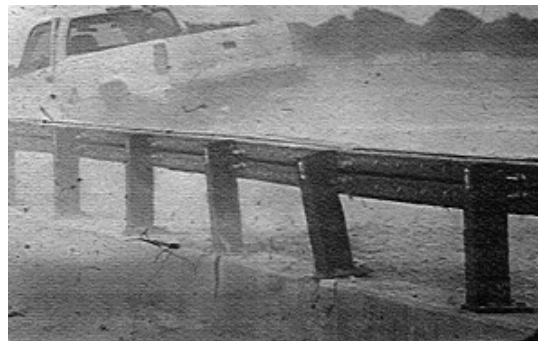

h) Rear at 1.610 s.

Figure 218. Sequential photographs for test 405181-21 (rear view).



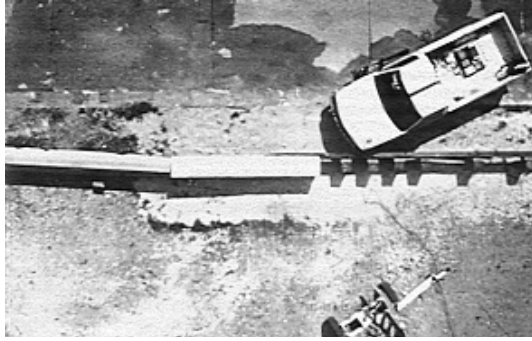

a) Overhead at 0.000 s.



e) Overhead at 0.621 s.



b) Overhead at 0.095 s.

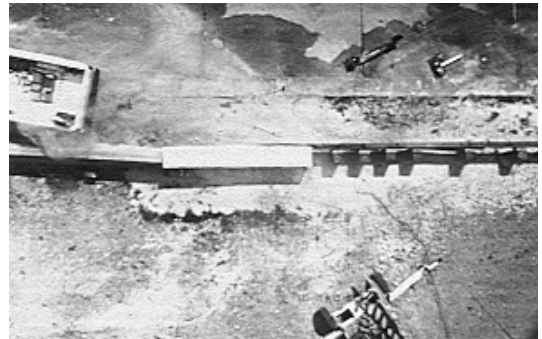

f) Overhead at 0.955 s.



c) Overhead at 0.191 s.

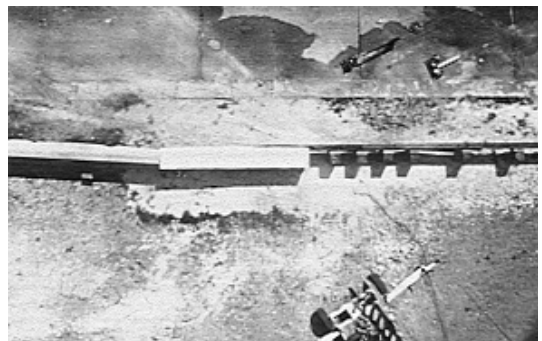

g) Overhead at 1.671 s.



d) Overhead at 0.382 s.

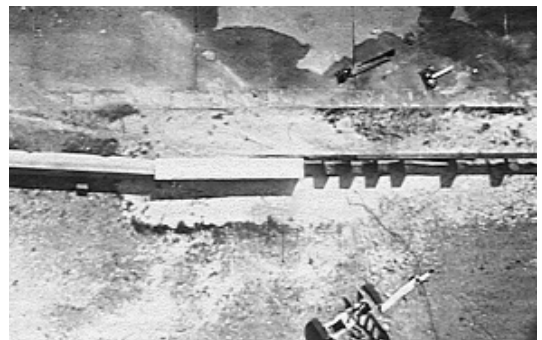

h) Overhead at 3.103 s.

Figure 219. Sequential photographs for test 405181-5a (overhead view).



a) Frontal at 0.000 s.



e) Frontal at 0.621 s.



b) Frontal at 0.095 s.



f) Frontal at 0.955 s.



c) Frontal at 0.191 s.



g) Frontal at 1.671 s.



d) Frontal at 0.382 s.



h) Frontal at 3.103 s.

Figure 220. Sequential photographs for test 405181-5a (frontal view).



a) Rear at 0.000 s.



e) Rear at 0.621 s.



b) Rear at 0.095 s.



f) Rear at 0.955 s.



c) Rear at 0.191 s.



g) Rear at 1.671 s.



d) Rear at 0.382 s.



h) Rear at 3.103 s.

Figure 221. Sequential photographs for test 405181-5a (rear view).



a) Overhead at 0.000 s.

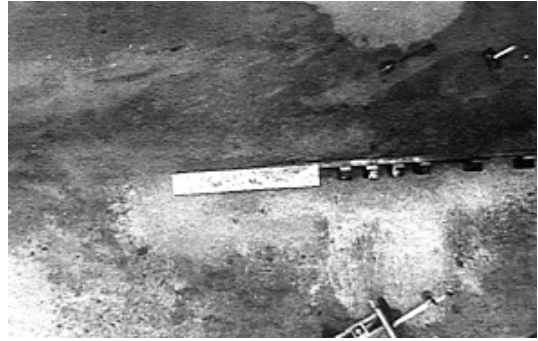

e) Overhead at 0.730 s.



b) Overhead at 0.097 s.



f) Overhead at 1.459 s.



c) Overhead at 0.195 s.



g) Overhead at 2.432 s.

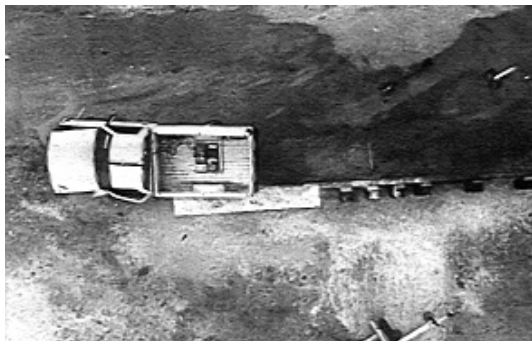

d) Overhead at 0.365 s.

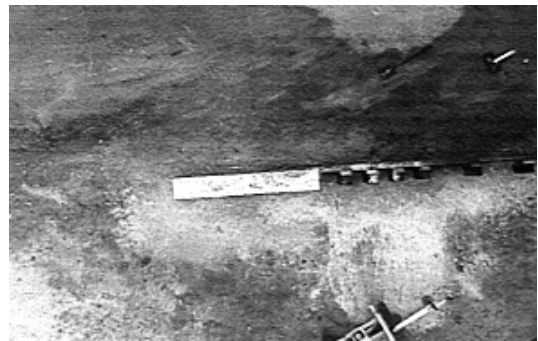

h) Overhead at 4.134 s.

Figure 222. Sequential photographs for test 405181-18 (overhead view).



a) Frontal at 0.000 s.



e) Frontal at 0.730 s.



b) Frontal at 0.097 s.



f) Frontal at 1.459 s.



c) Frontal at 0.195 s.



g) Frontal at 2.432 s.



d) Frontal at 0.365 s.



h) Frontal at 4.134 s.

Figure 223. Sequential photographs for test 405181-18 (frontal view).



a) Rear at 0.000 s.



e) Rear at 0.730 s.



b) Rear at 0.097 s.



f) Rear at 1.459 s.



c) Rear at 0.195 s.



g) Rear at 2.432 s.



d) Rear at 0.365 s.



h) Rear at 4.134 s.

Figure 224. Sequential photographs for test 405181-18 (rear view).

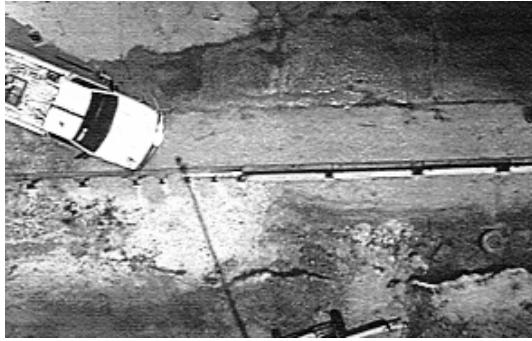

a) Overhead at 0.000 s.



e) Overhead at 0.499 s.



b) Overhead at 0.050 s.

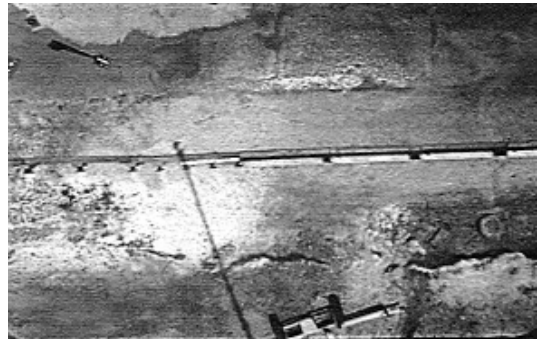

f) Overhead at 0.998 s.



c) Overhead at 0.150 s.



g) Overhead at 1.995 s.

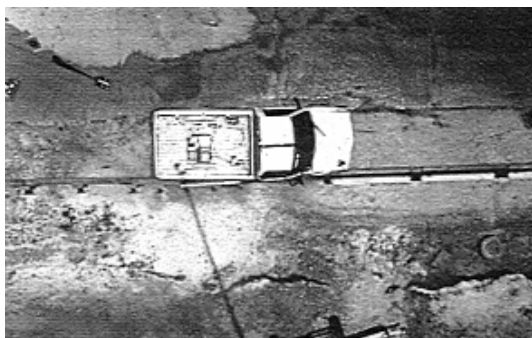

d) Overhead at 0.249 s.



h) Overhead at 3.741 s.

Figure 225. Sequential photographs for test 405181-22 (overhead view).



a) Frontal at 0.000 s.



e) Frontal at 0.499 s.



b) Frontal at 0.050 s.



f) Frontal at 0.998 s.



c) Frontal at 0.150 s.



g) Frontal at 1.995 s.



d) Frontal at 0.249 s.



h) Frontal at 3.741 s.

Figure 226. Sequential photographs for test 405181-22 (frontal view).





a) Rear at 0.000 s.



e) Rear at 0.499 s.

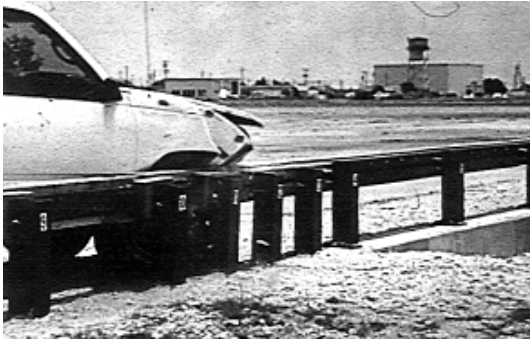

b) Rear at 0.050 s.



f) Rear at 0.998 s.



c) Rear at 0.150 s.



g) Rear at 1.995 s.



d) Rear at 0.249 s.



h) Rear at 3.741 s.

Figure 227. Sequential photographs for test 405181-22 (rear view).



## APPENDIX D. VEHICLE ANGULAR DISPLACEMENTS AND ACCELERATIONS

Axes are vehicle fixed.  
Sequence for determining orientation:

1. Yaw.
2. Pitch.
3. Roll.

x, y, and z are axis labels for a conventional, three-dimensional, orthogonal, Cartesian coordinate system.

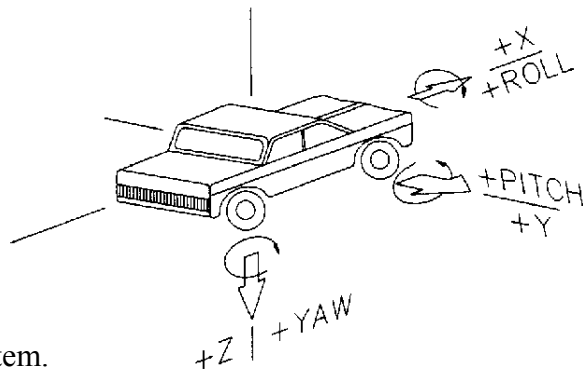

Figure 228. Vehicle coordinates.

# Roll, Pitch, and Yaw Angles

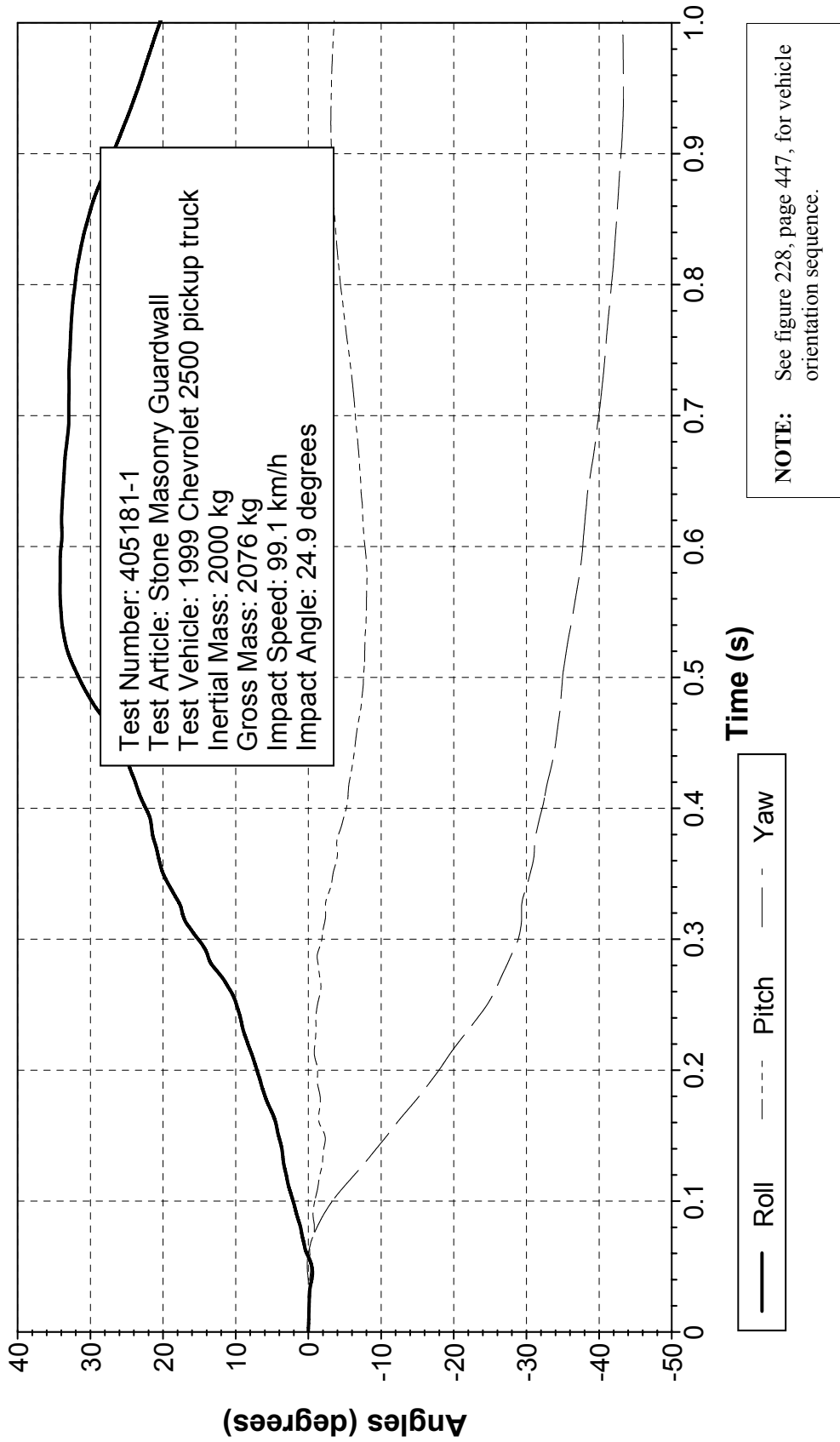

Figure 229. Vehicle angular displacements for test 405181-1.

# X Acceleration at C.G.

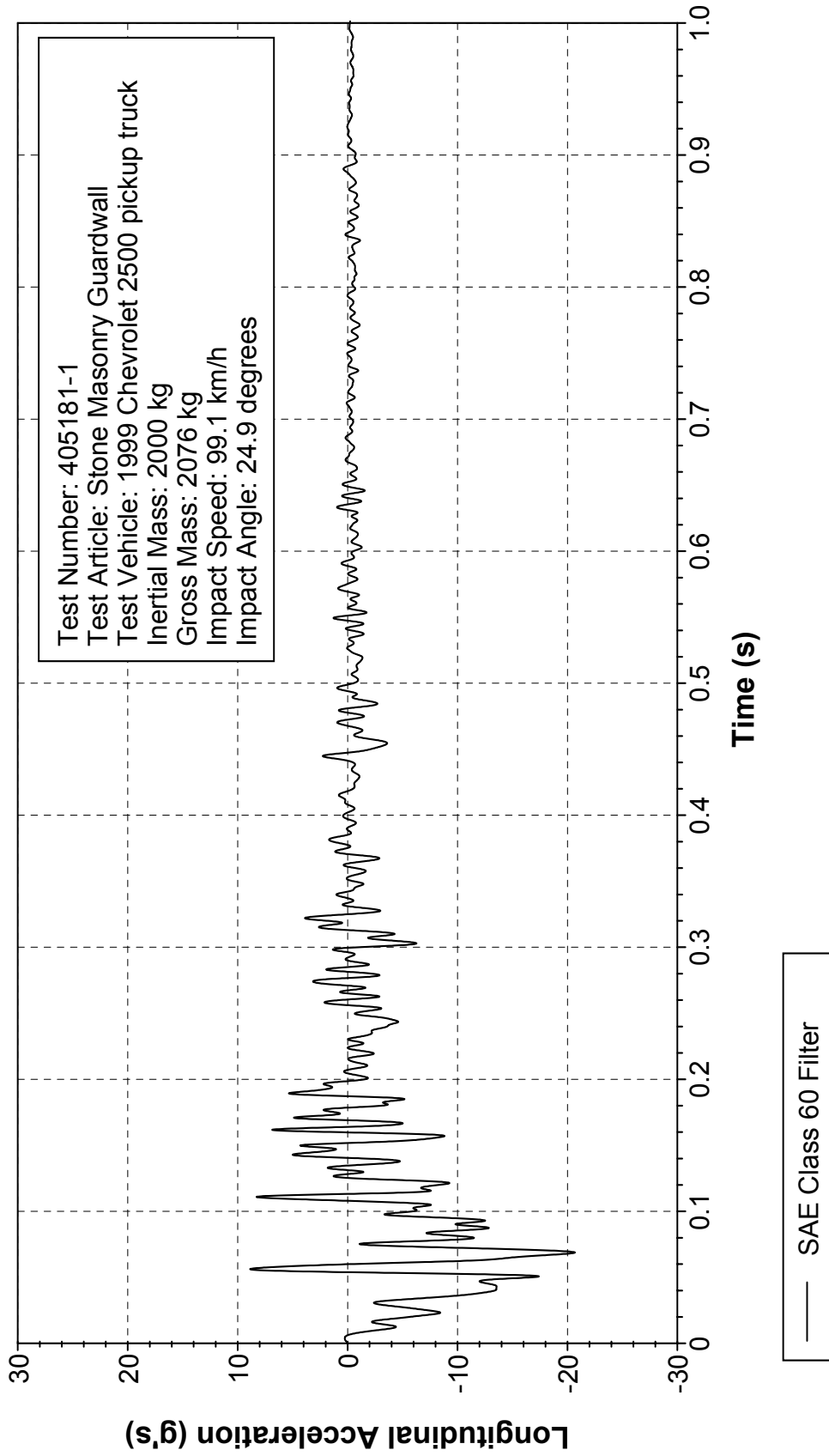

Figure 230. Vehicle longitudinal accelerometer trace for test 405181-1 (accelerometer located at center of gravity).

# Y Acceleration at C.G.

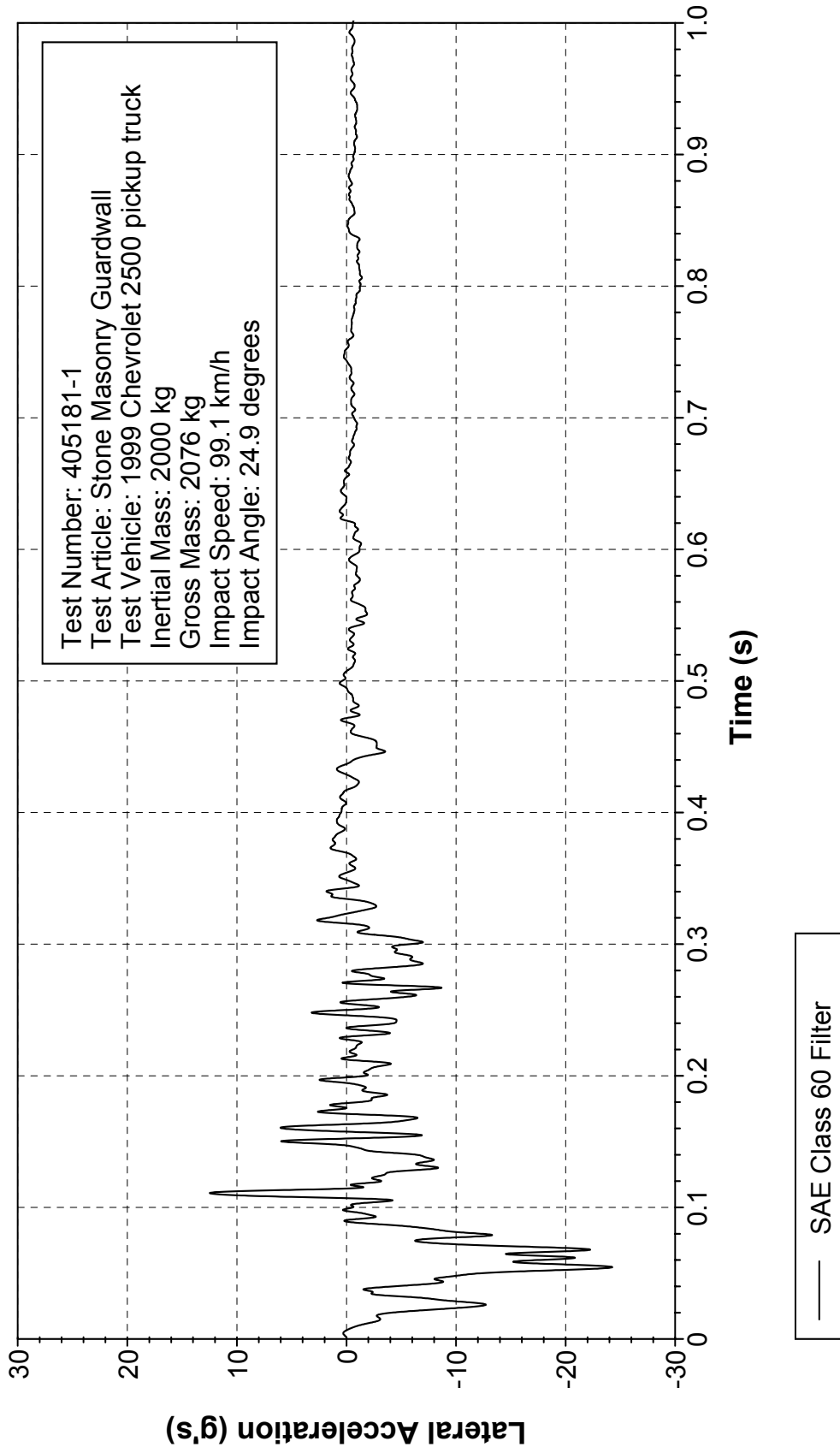

Figure 231. Vehicle lateral accelerometer trace for test 405181-1 (accelerometer located at center of gravity).

# Z Acceleration at C.G.

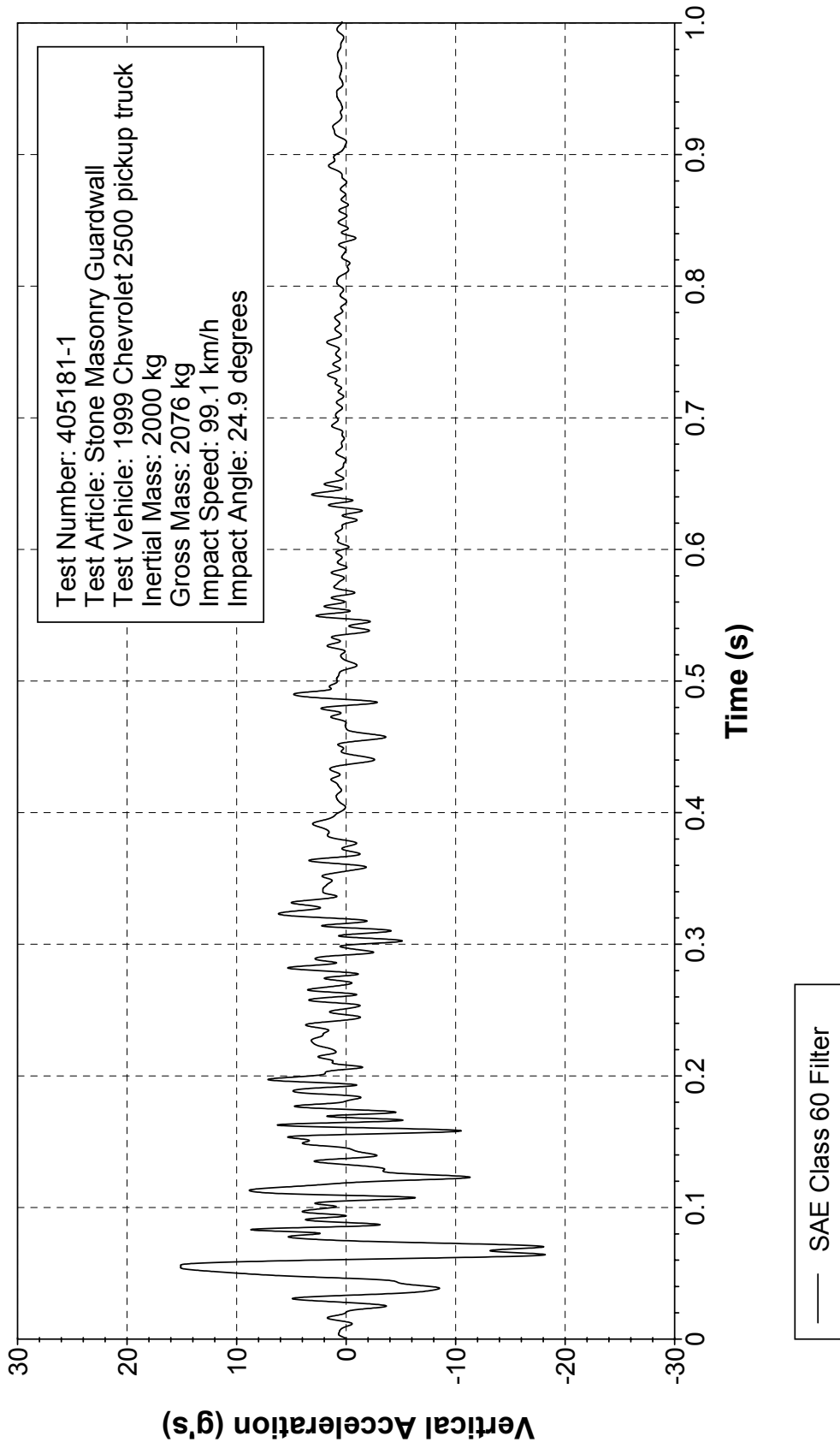

Figure 232. Vehicle vertical accelerometer trace for test 405181-1 (accelerometer located at center of gravity).

# X Acceleration over Rear Axle

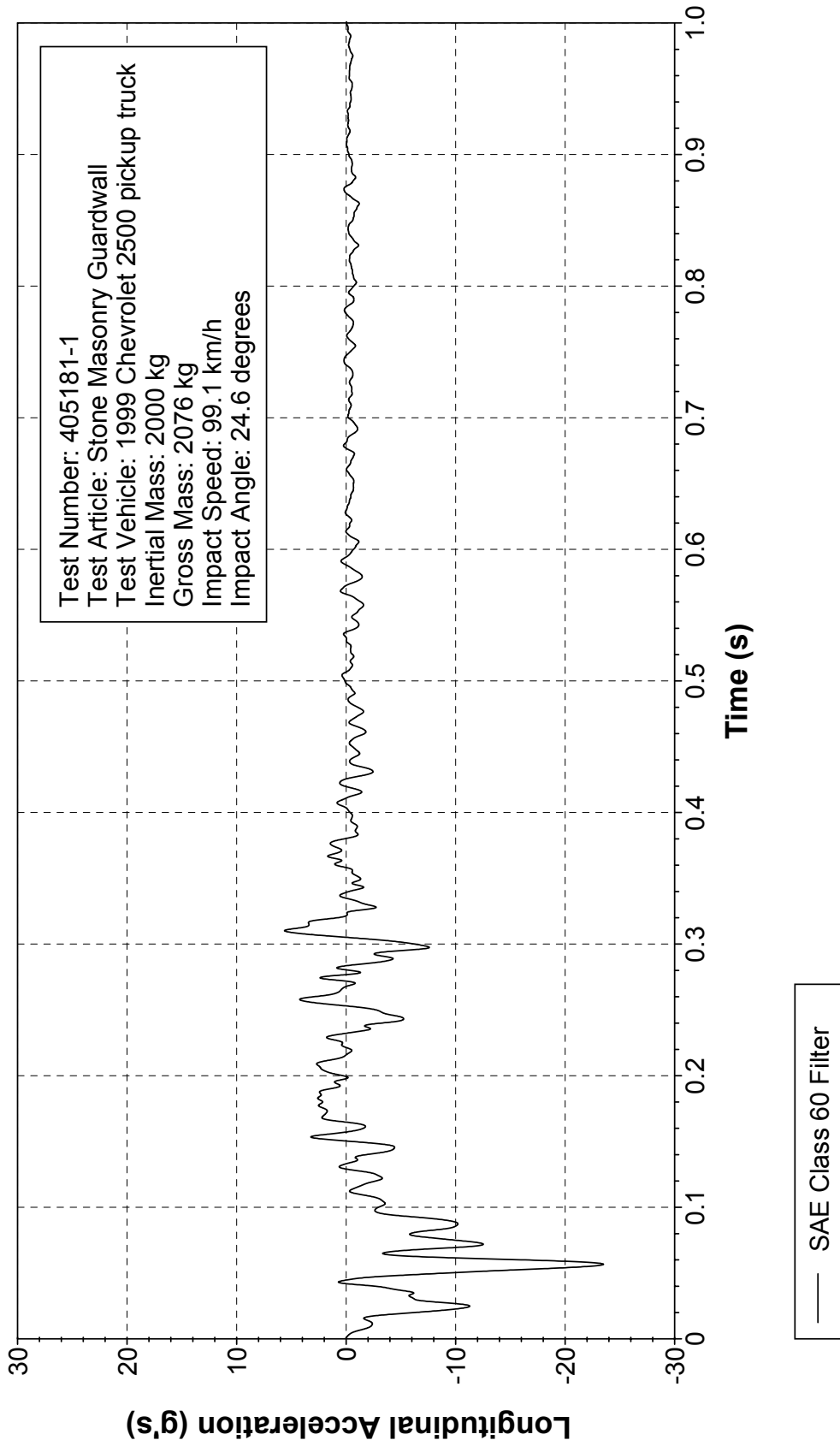

Figure 233. Vehicle longitudinal accelerometer trace for test 405181-1 (accelerometer located over rear axle).



# Y Acceleration over Rear Axle

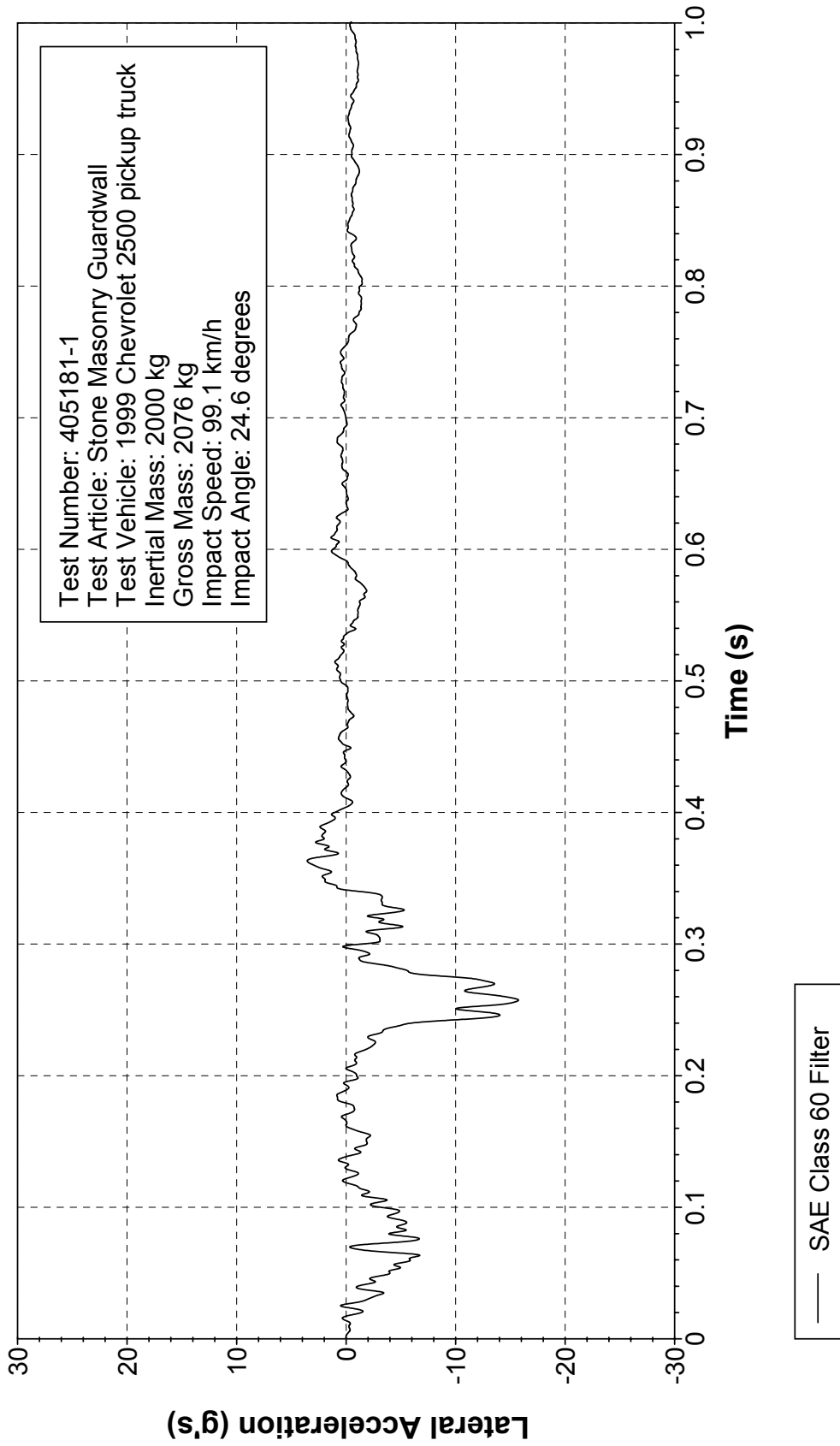

Figure 234. Vehicle lateral accelerometer trace for test 405181-1 (accelerometer located over rear axle).

# Z Acceleration over Rear Axle

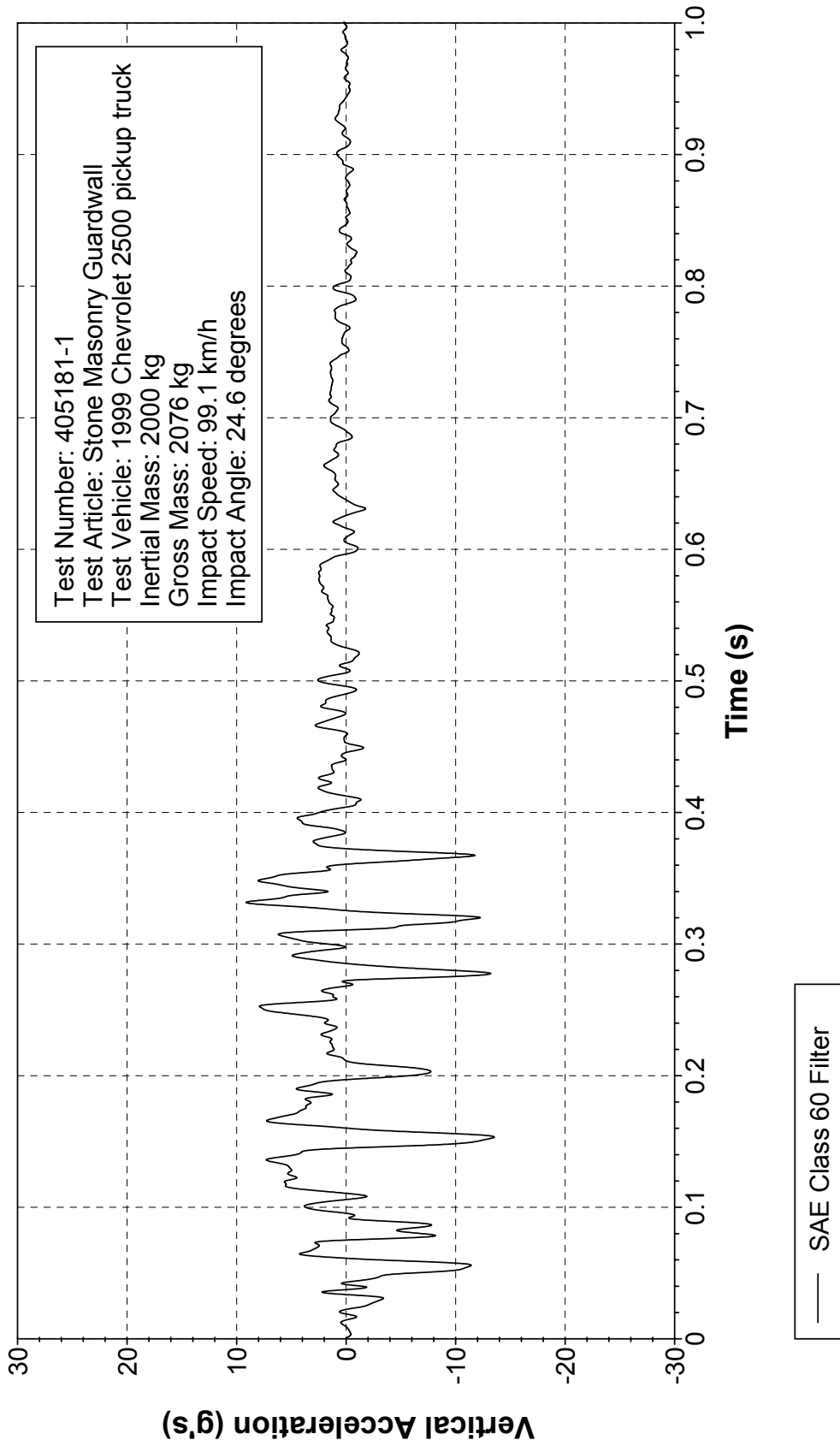

Figure 235. Vehicle vertical accelerometer trace for test 405181-1 (accelerometer located over rear axle).

# Roll, Pitch, and Yaw Angles

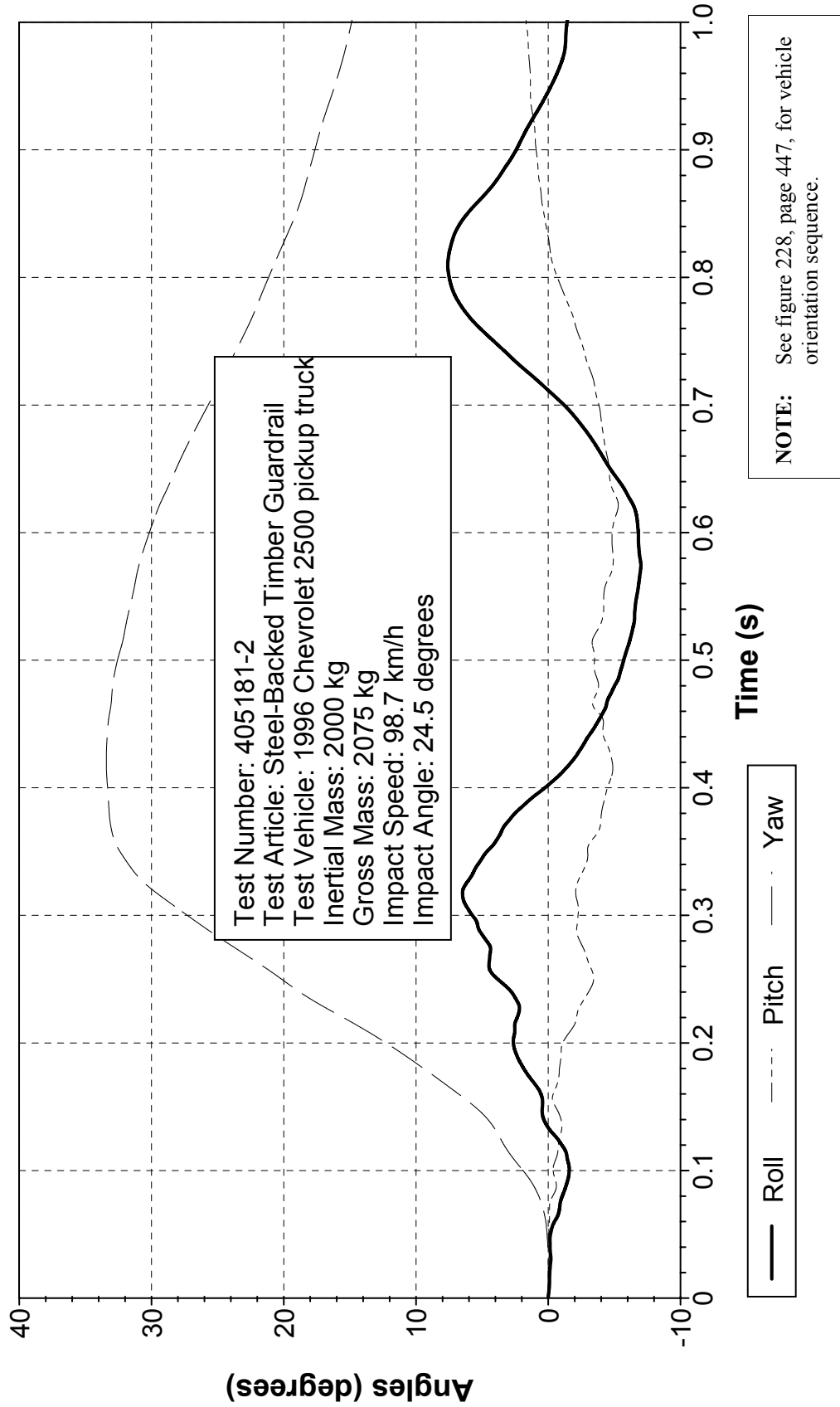

Figure 236. Vehicle angular displacements for test 405181-2.

# X Acceleration at C.G.

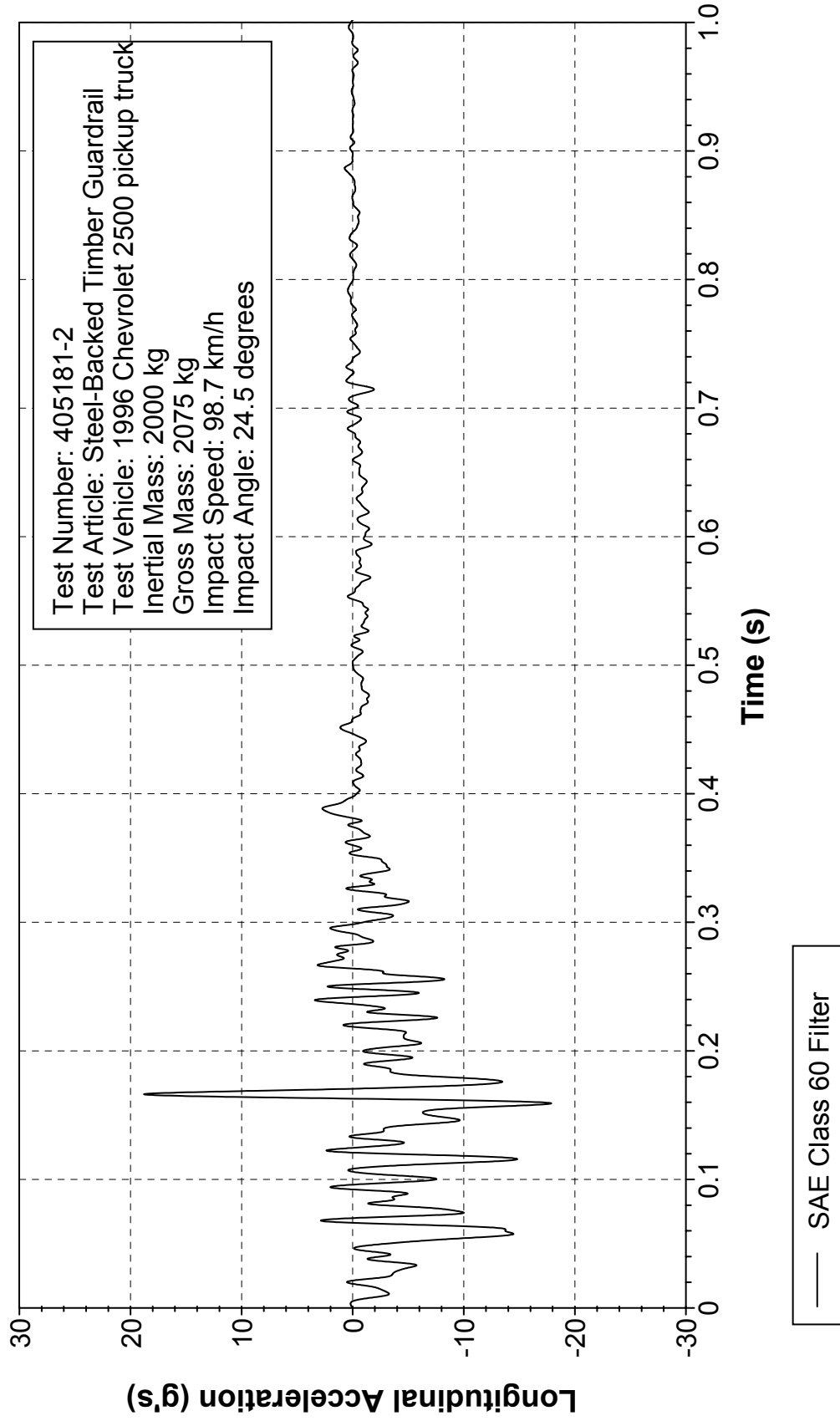

Figure 237. Vehicle longitudinal accelerometer trace for test 405181-2 (accelerometer located at center of gravity).

# Y Acceleration at C.G.

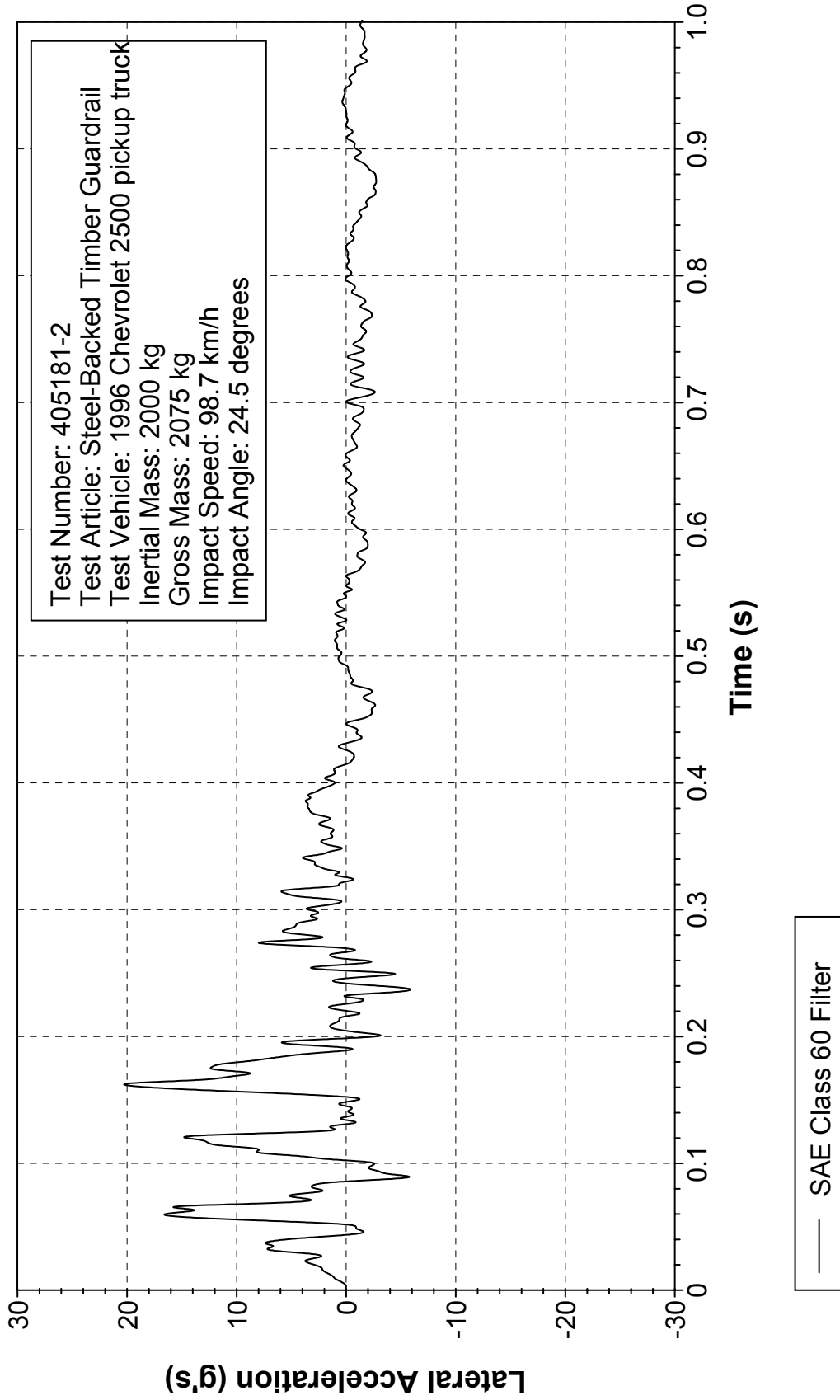

Figure 238. Vehicle lateral accelerometer trace for test 405181-2 (accelerometer located at center of gravity).

# Z Acceleration at C.G.

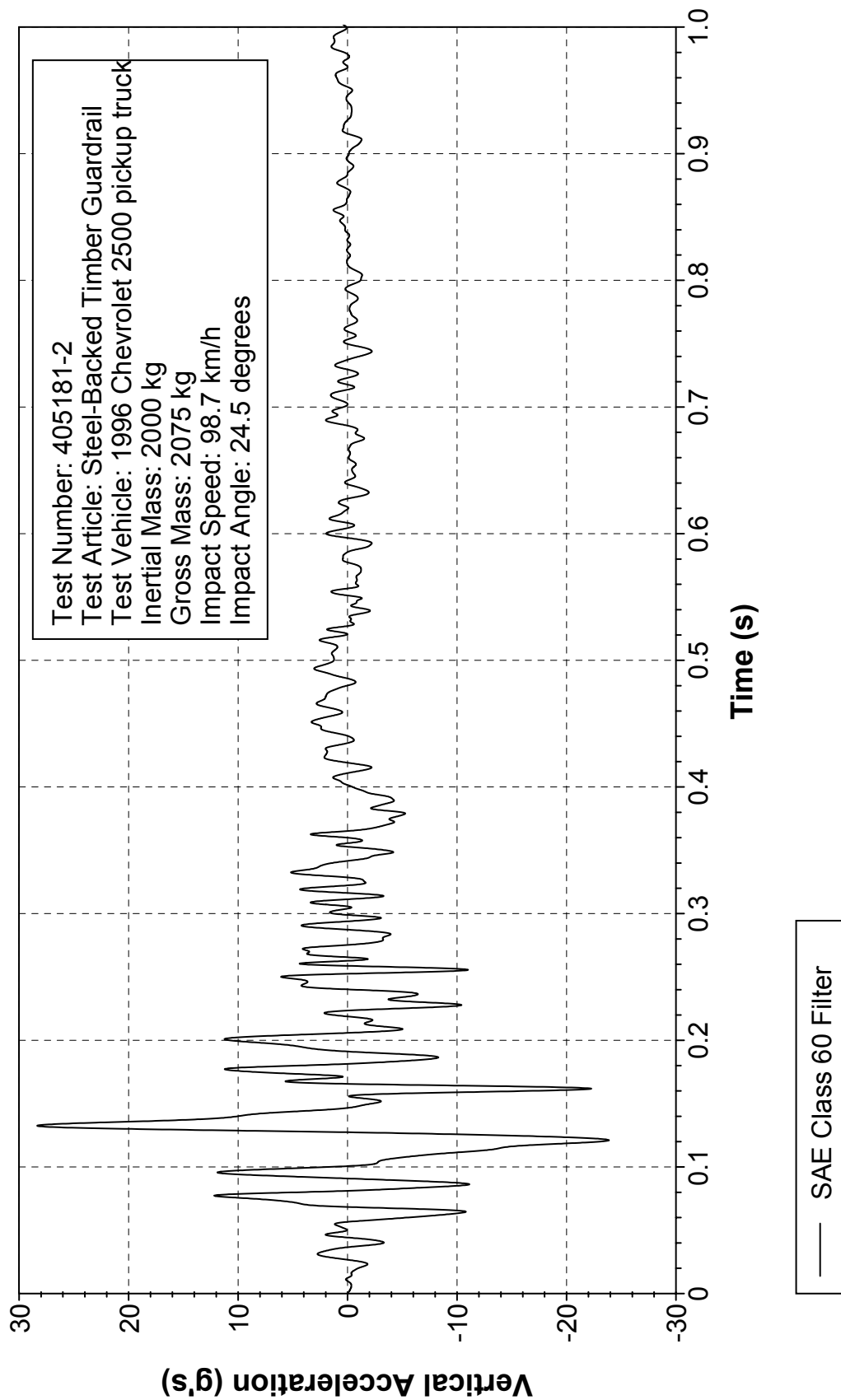

Figure 239. Vehicle vertical accelerometer trace for test 405181-2 (accelerometer located at center of gravity).

# X Acceleration over Rear Axle

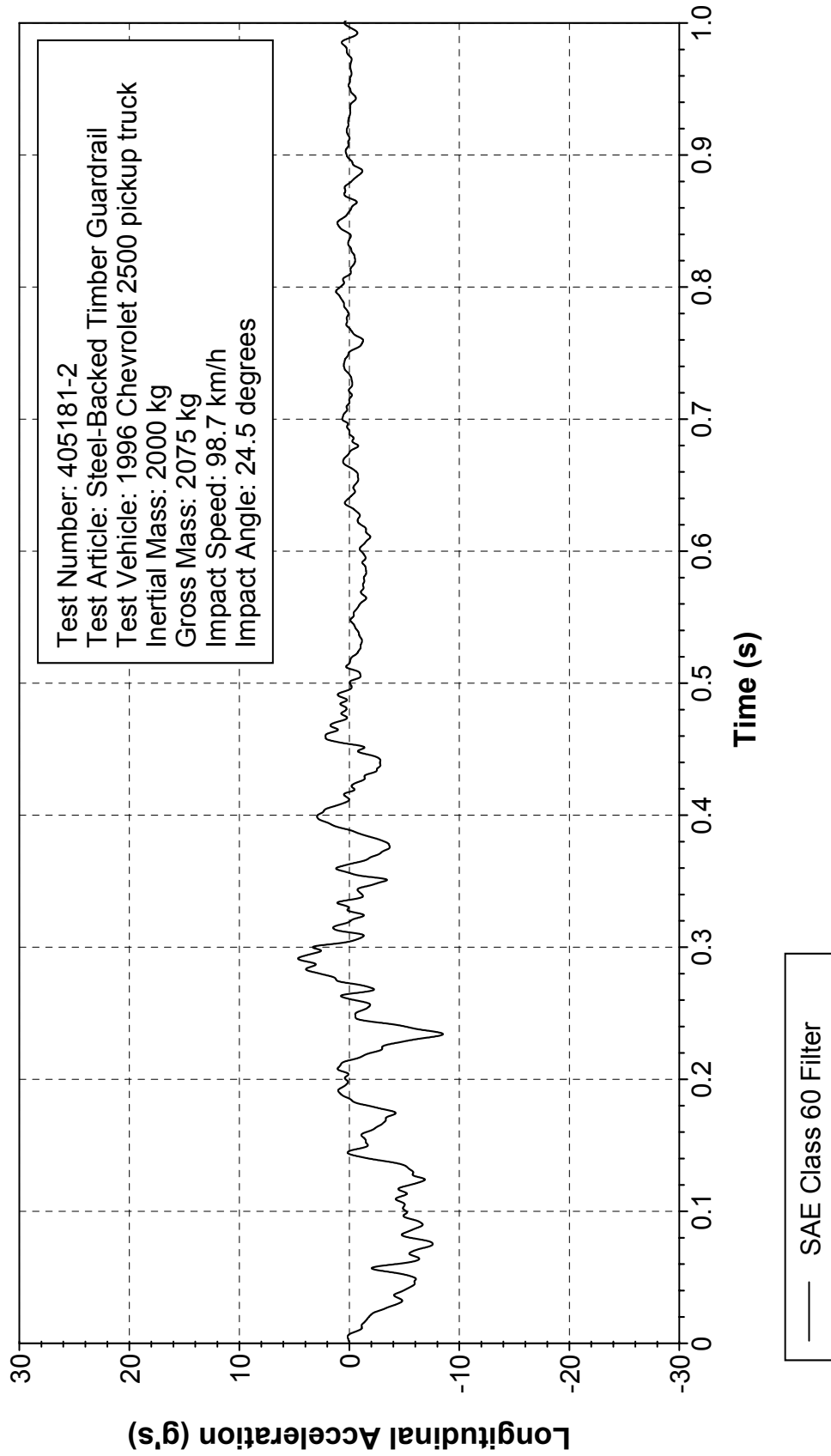

Figure 240. Vehicle longitudinal accelerometer trace for test 405181-2 (accelerometer located over rear axle).

# Y Acceleration over Rear Axle

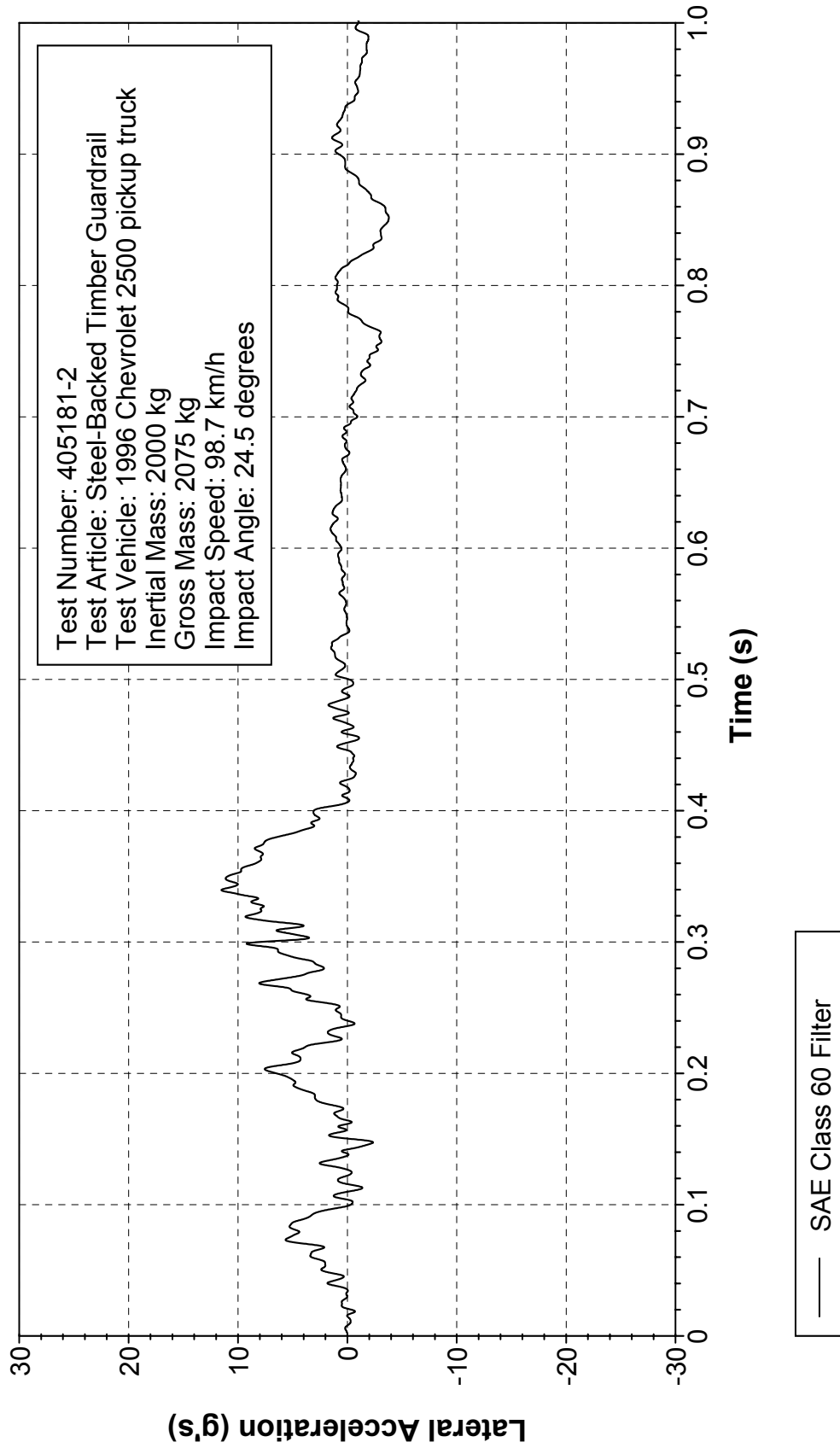

Figure 241. Vehicle lateral accelerometer trace for test 405181-2 (accelerometer located over rear axle).



# Z Acceleration over Rear Axle

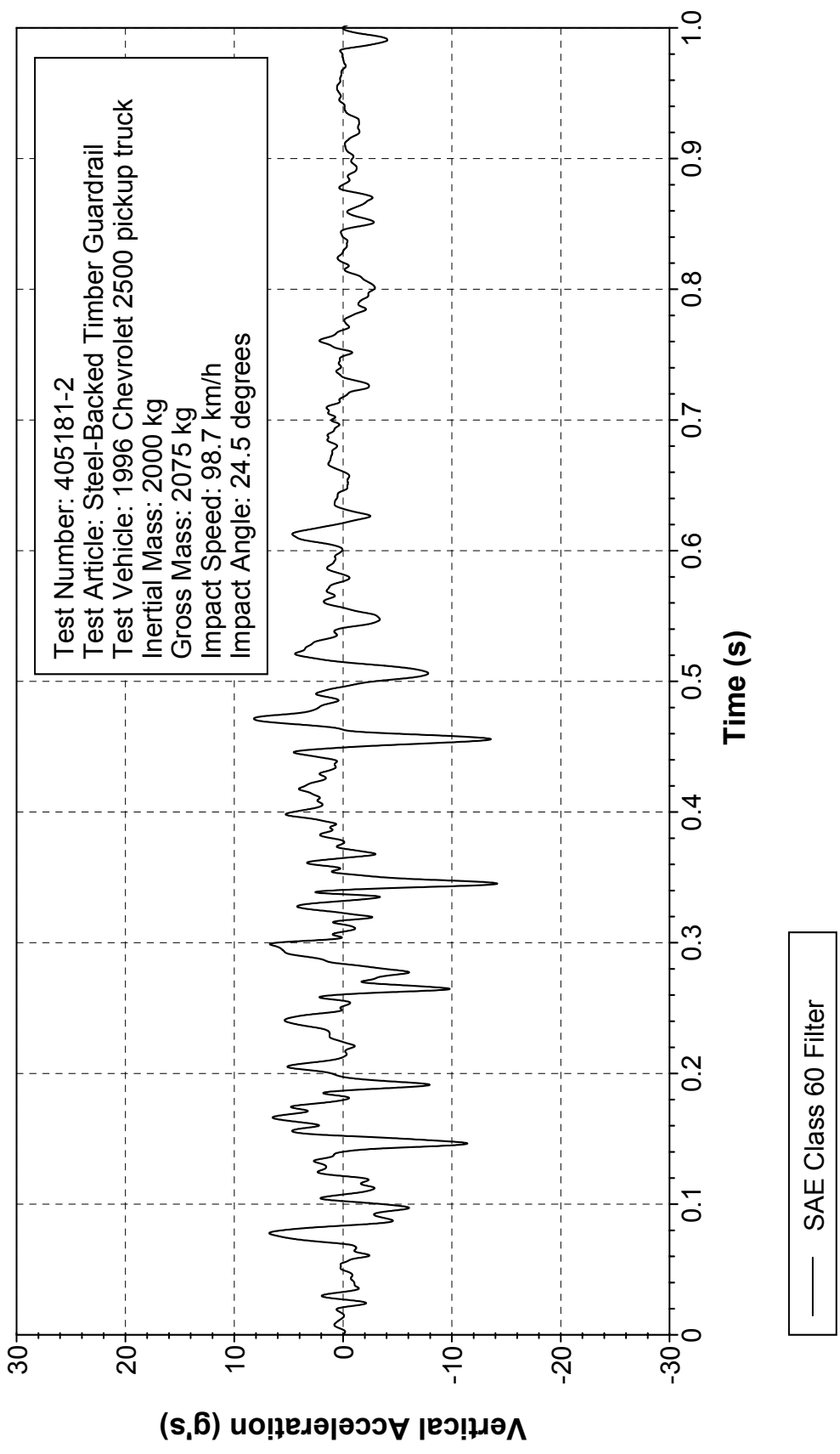

Figure 242. Vehicle vertical accelerometer trace for test 405181-2 (accelerometer located over rear axle).

# Roll, Pitch, and Yaw Angles

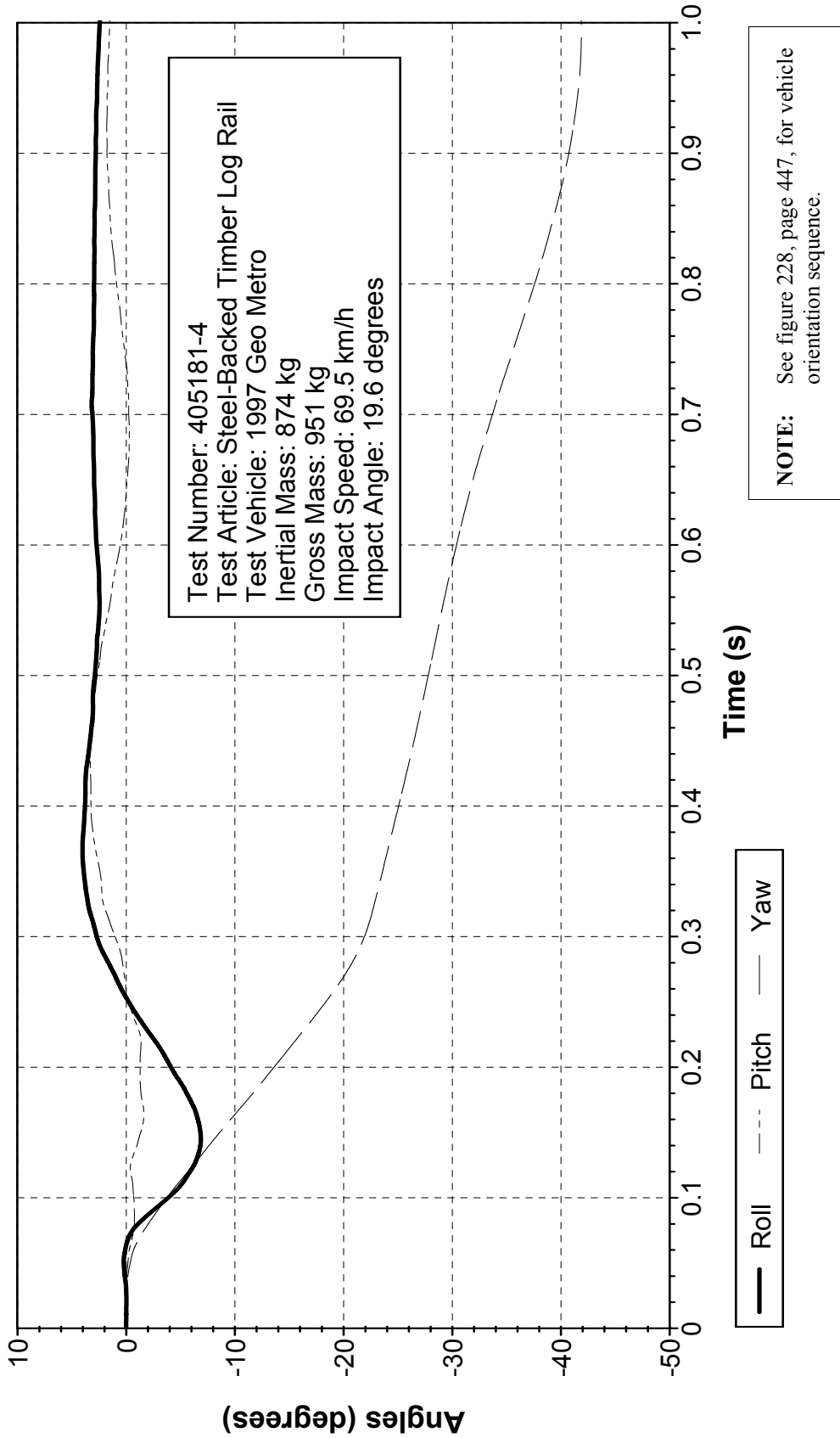

Figure 243. Vehicle angular displacements for test 405181-4.

# X Acceleration at C.G.

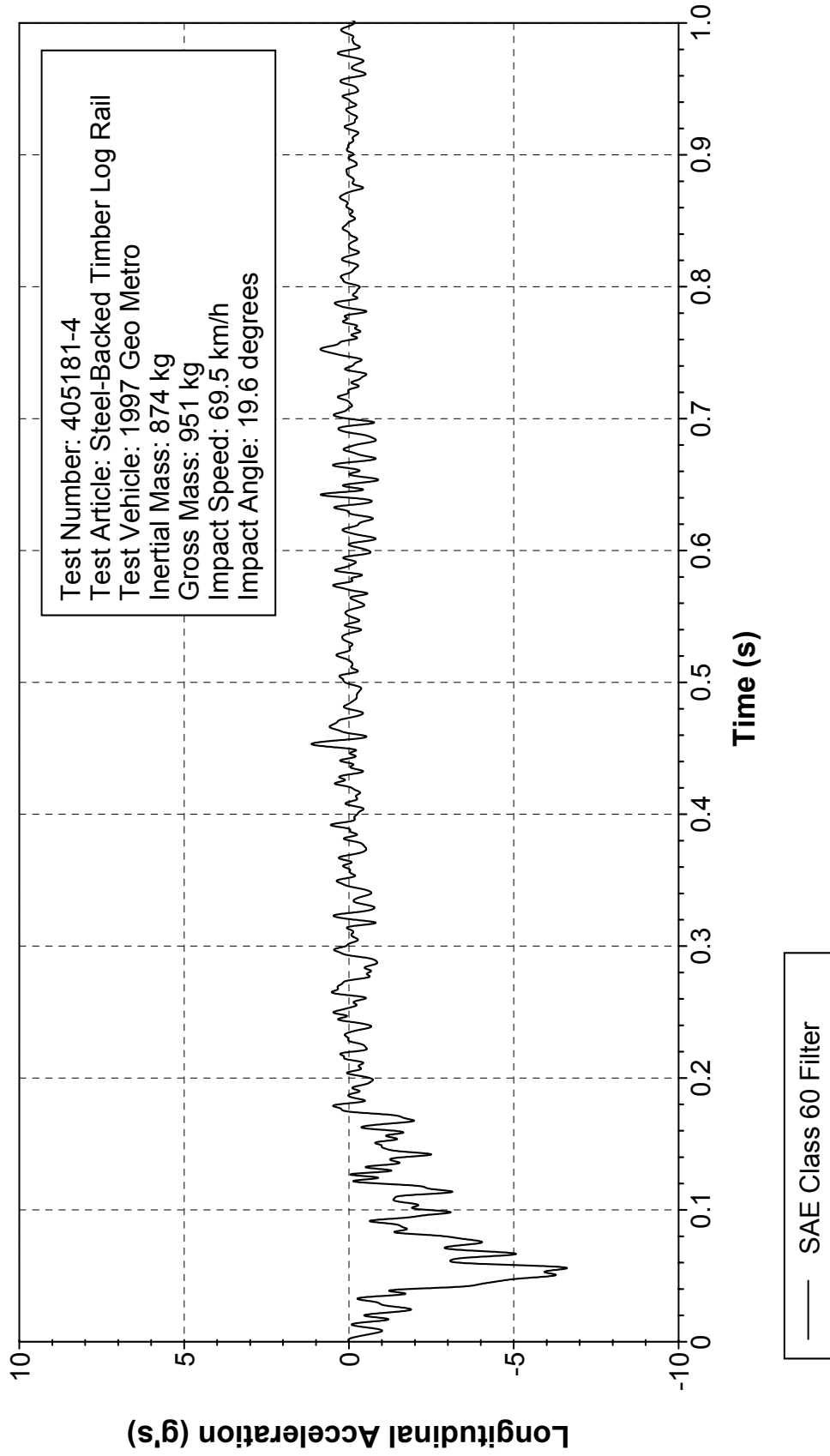

Figure 244. Vehicle longitudinal accelerometer trace for test 405181-4 (accelerometer located at center of gravity).

# Y Acceleration at C.G.

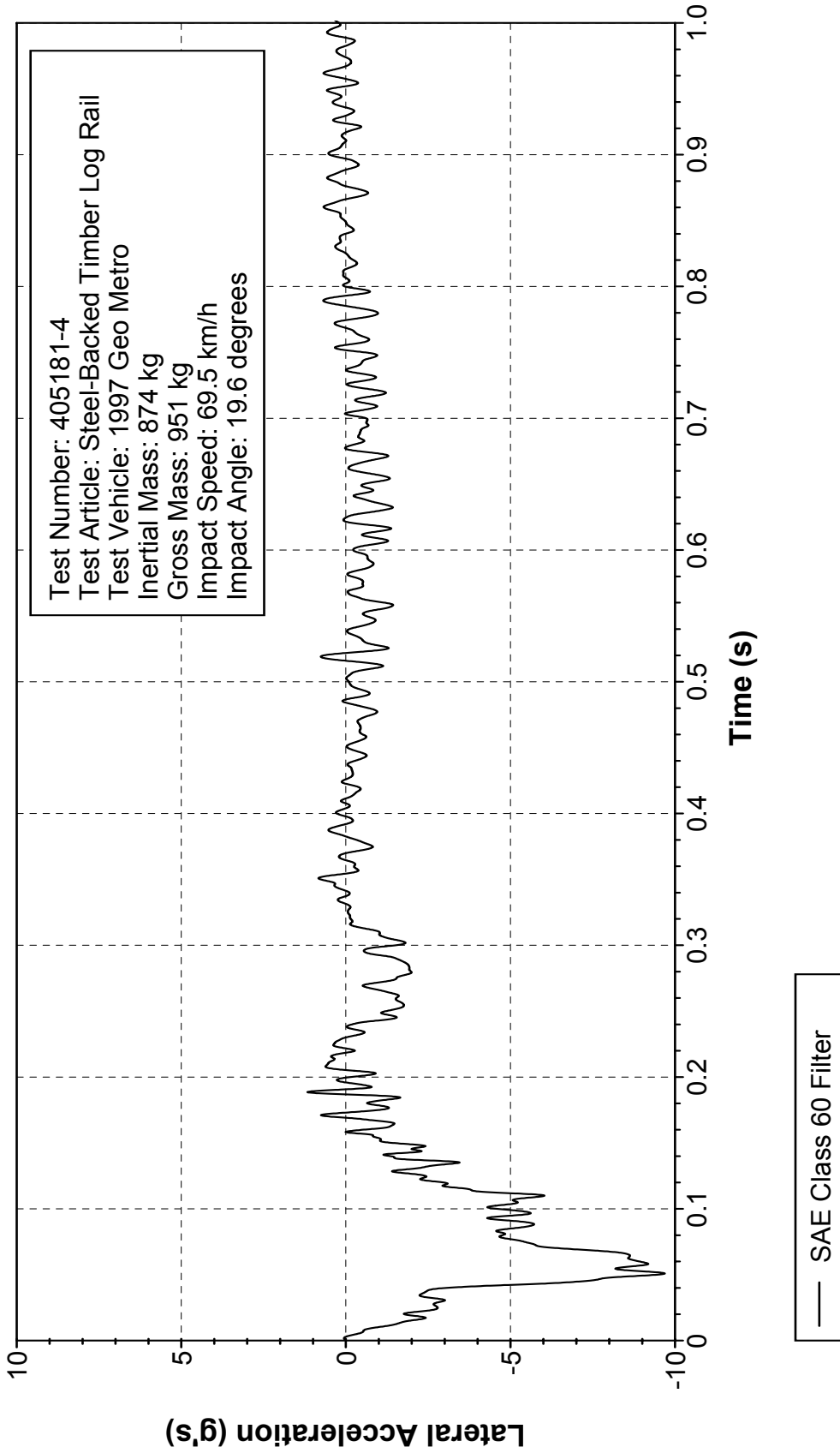

Figure 245. Vehicle lateral accelerometer trace for test 405181-4 (accelerometer located at center of gravity).

# Z Acceleration at C.G.

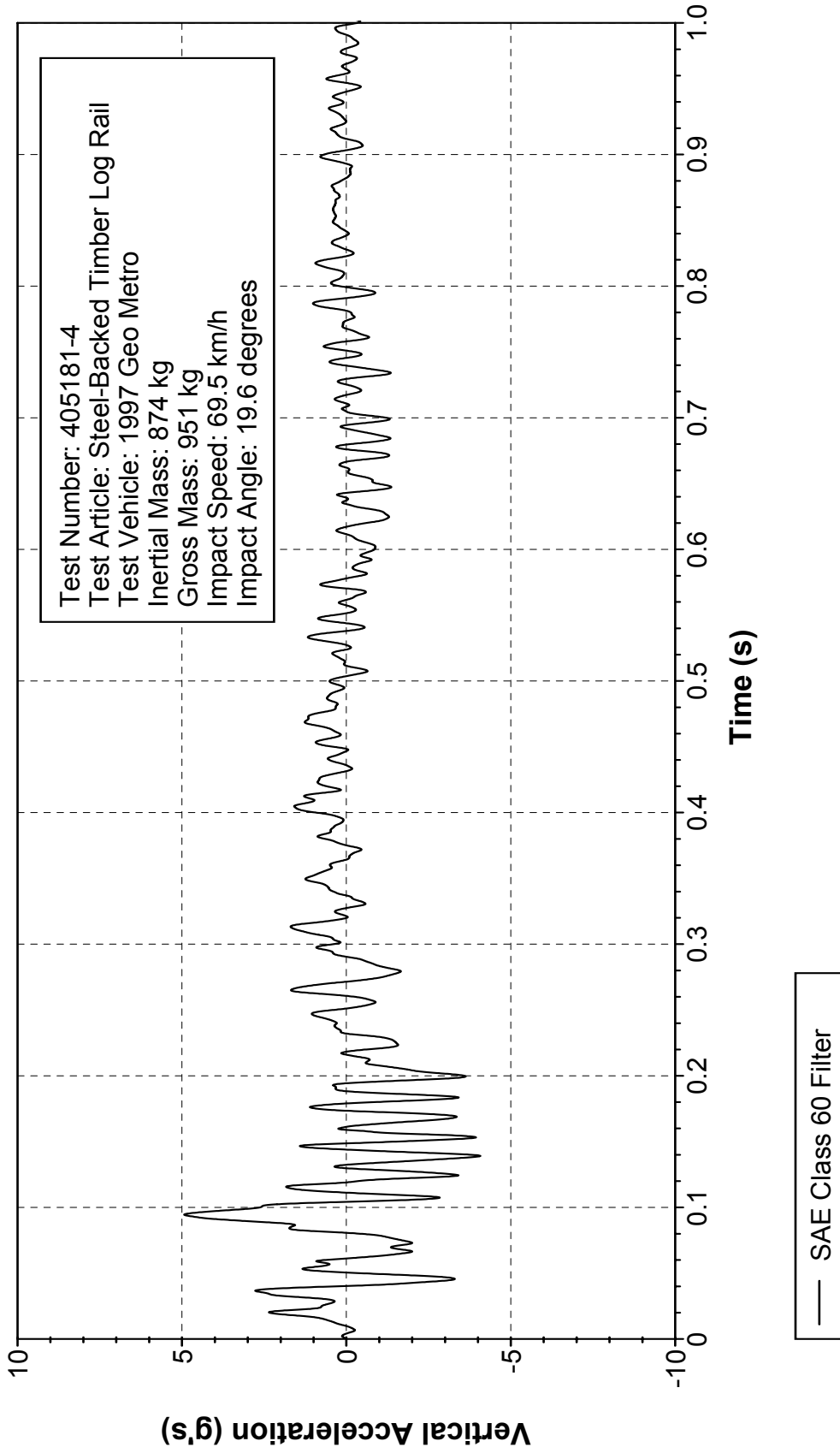

Figure 246. Vehicle vertical accelerometer trace for test 405181-4 (accelerometer located at center of gravity).

# X Acceleration over Rear Axle

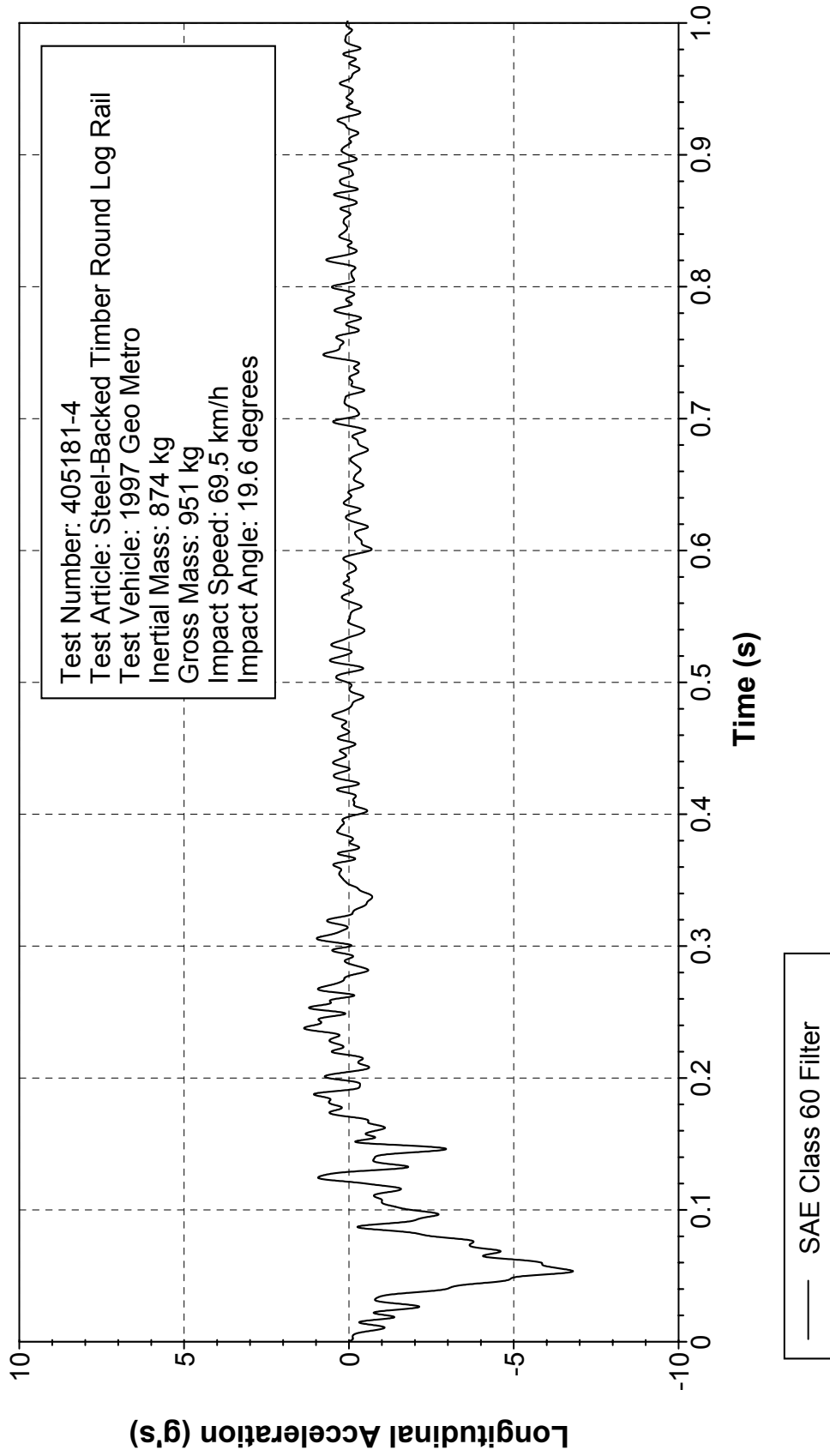

Figure 247. Vehicle longitudinal accelerometer trace for test 405181-4 (accelerometer located over rear axle).

# Y Acceleration over Rear Axle

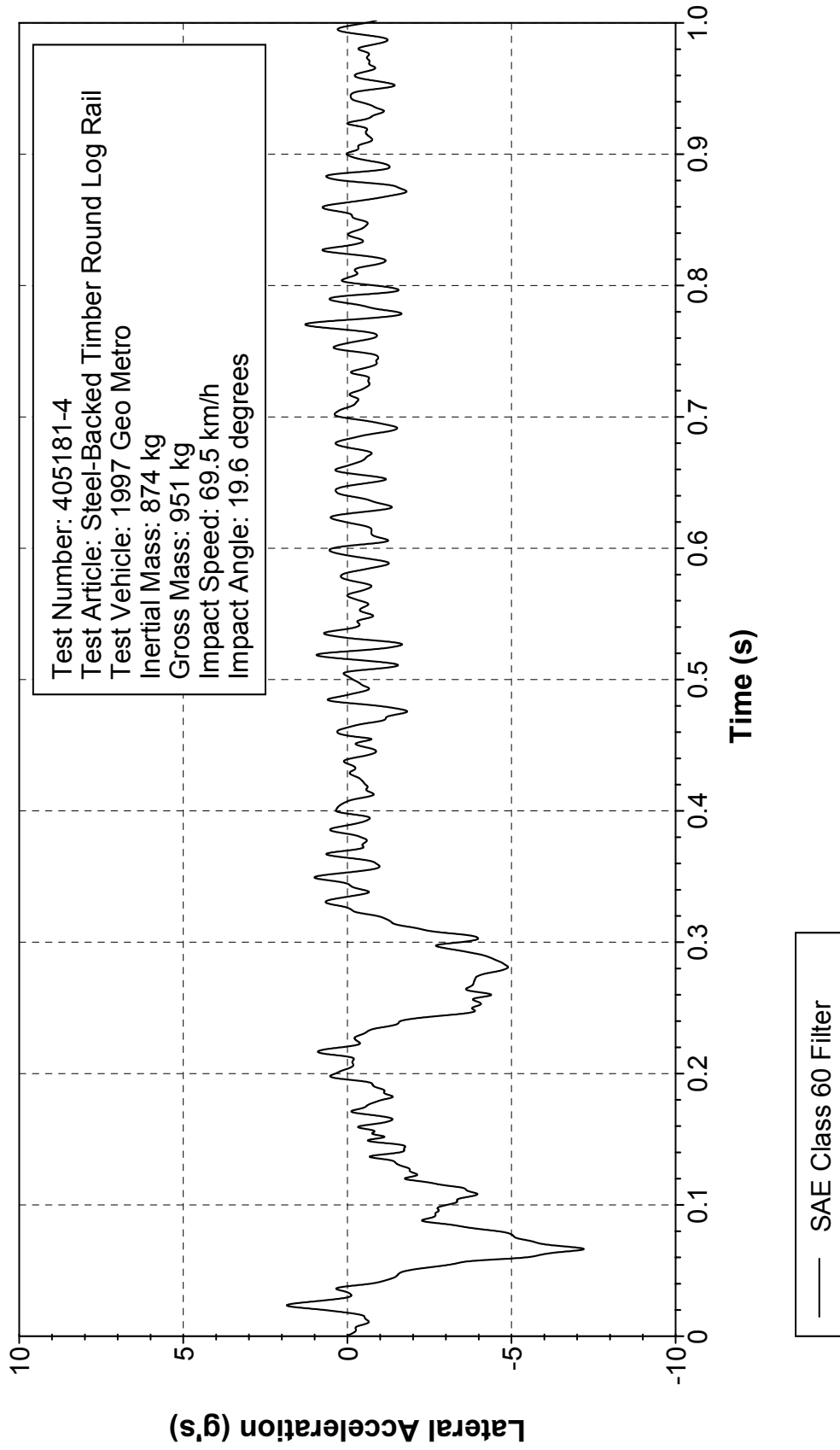

Figure 248. Vehicle lateral accelerometer trace for test 405181-4 (accelerometer located over rear axle).

# Z Acceleration over Rear Axle

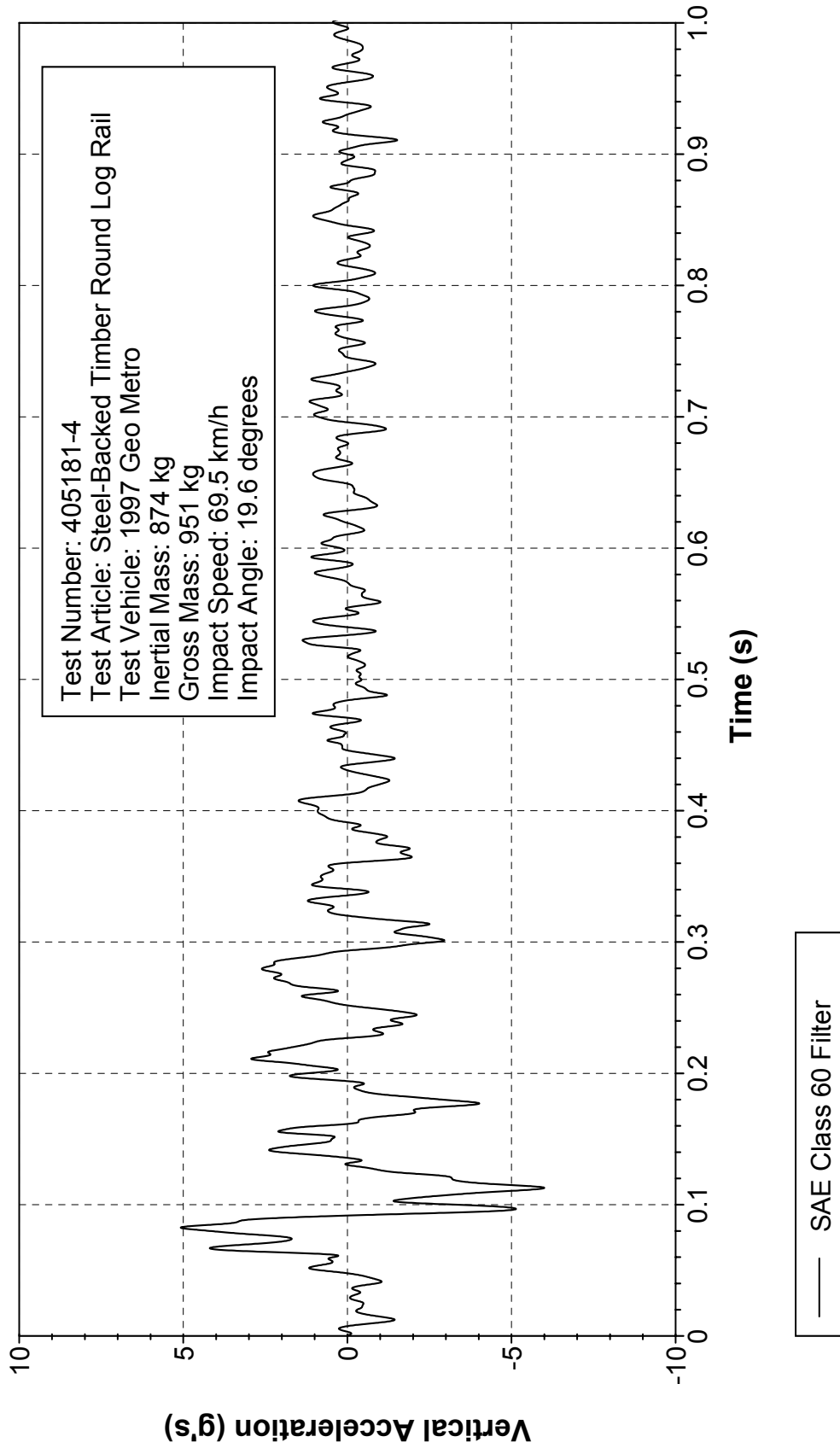

Figure 249. Vehicle vertical accelerometer trace for test 405181-4 (accelerometer located over rear axle).



### Crash Test 405181-4

#### Accelerometer on top of instrument panel surface

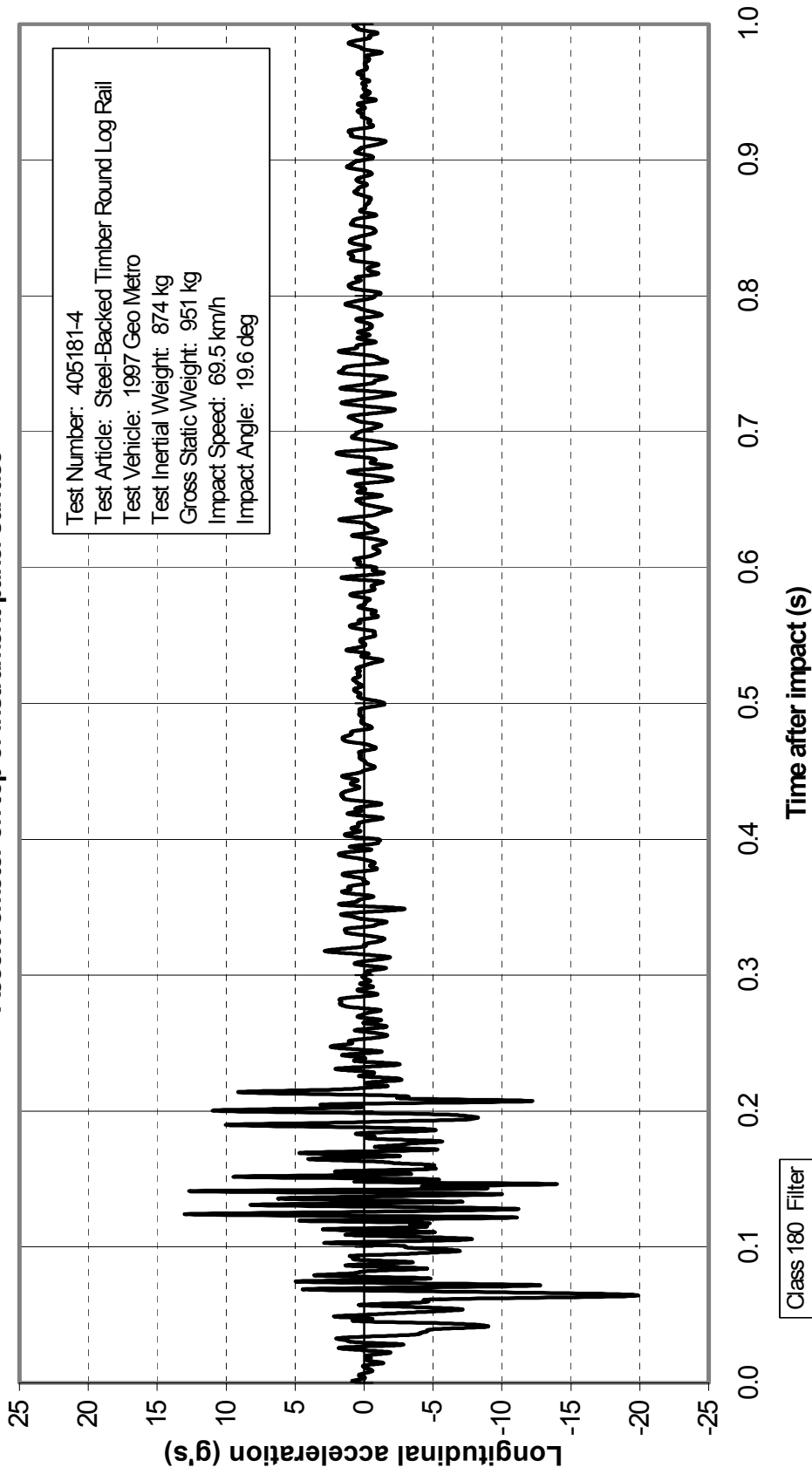

Figure 250. Vehicle longitudinal accelerometer trace for test 405181-4 (accelerometer located on top surface of instrument panel).

### Crash Test 405181-4

#### Accelerometer on right front brake caliper

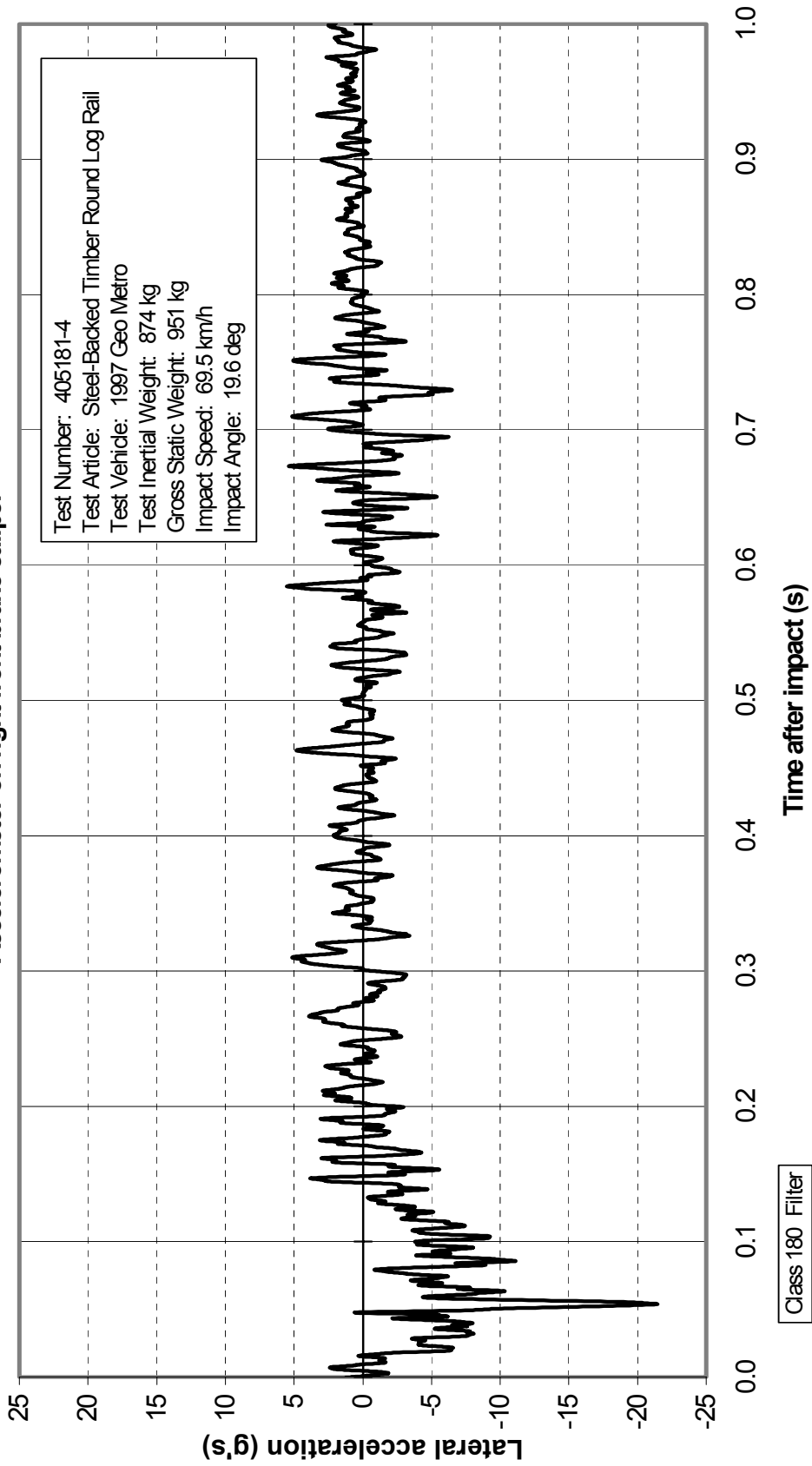

Figure 251. Vehicle lateral accelerometer trace for test 405181-4 (accelerometer located on right front brake caliper).

### Crash Test 405181-4

Accelerometer on left front brake caliper

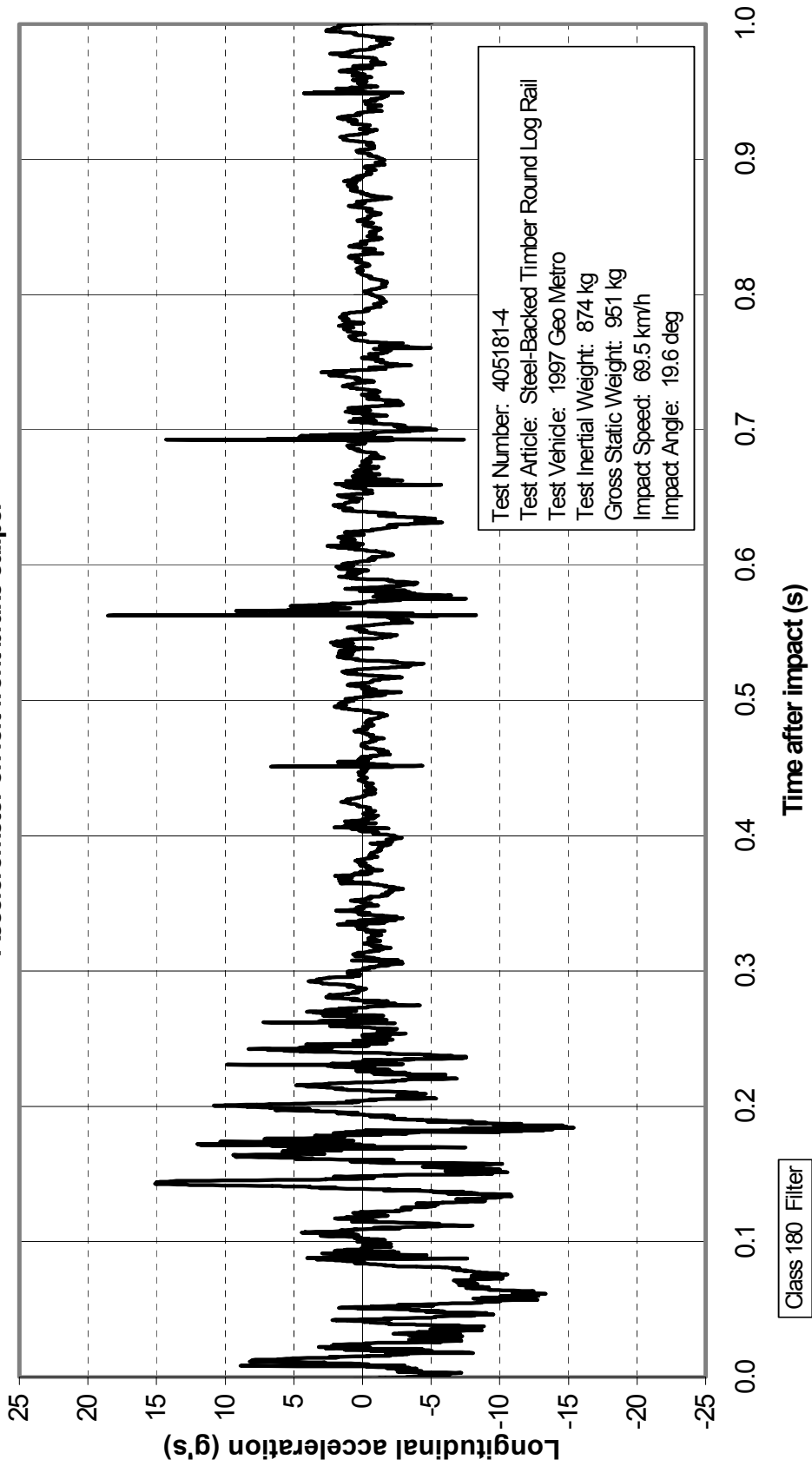

Figure 252. Vehicle longitudinal accelerometer trace for test 405181-4 (accelerometer located on left front brake caliper).

### Crash Test 405181-4 Accelerometer on top of engine block

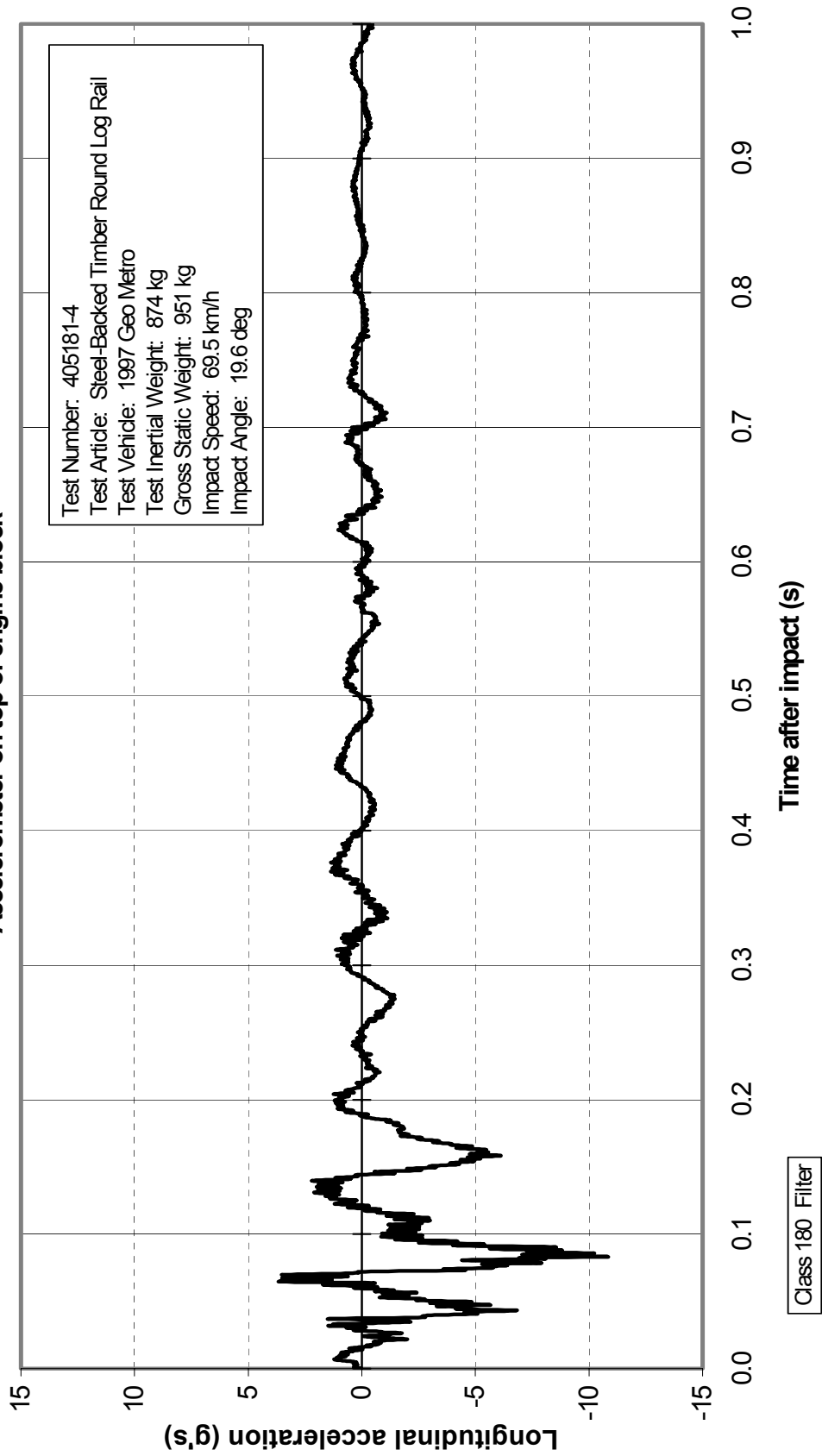

Figure 253. Vehicle longitudinal accelerometer trace for test 405181-4 (accelerometer located on top of engine block).

### Crash Test 405181-4

#### Accelerometer on bottom of engine block

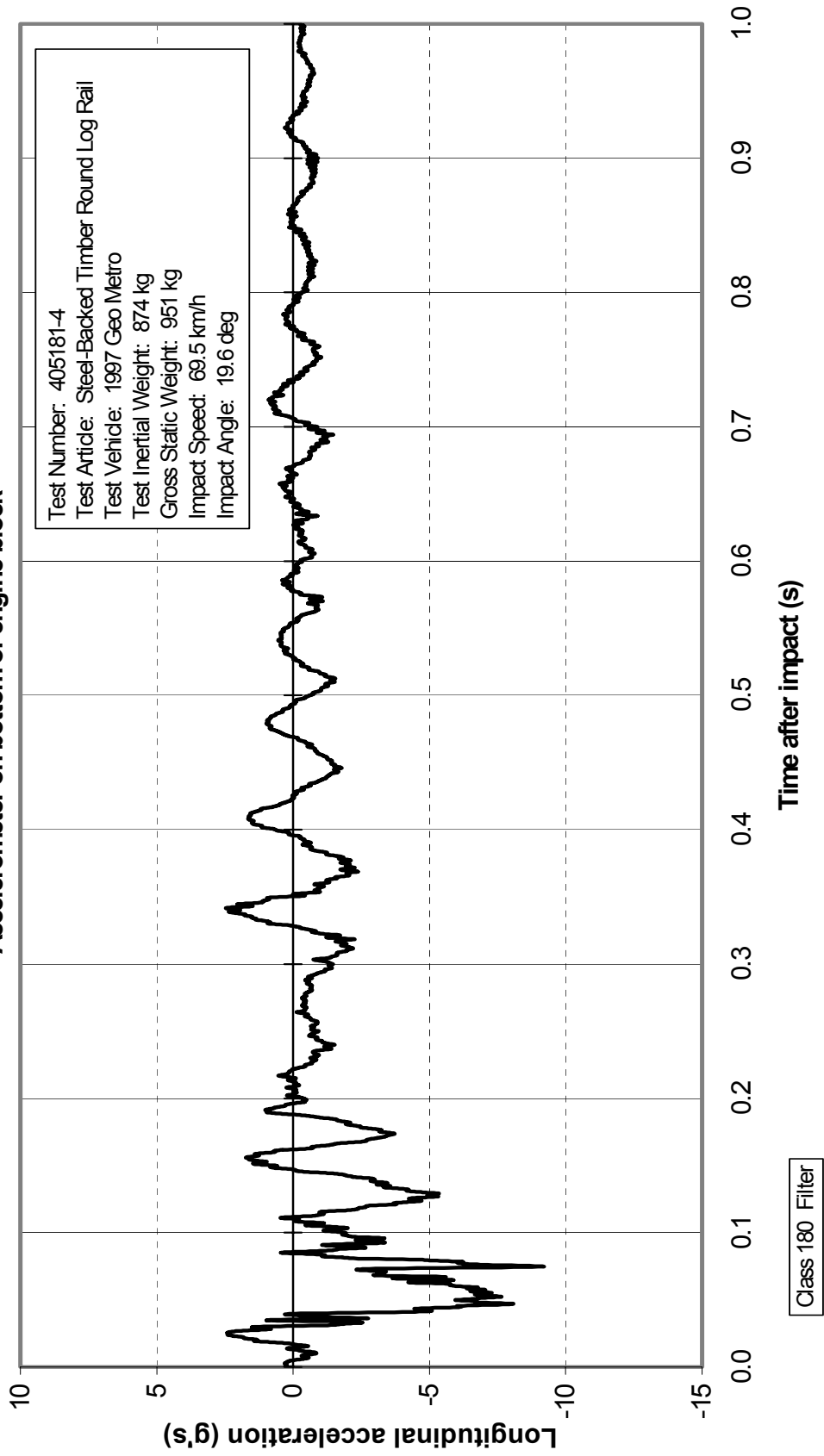

Figure 254. Vehicle longitudinal accelerometer trace for test 405181-4 (accelerometer located on bottom of engine block).

# Roll, Pitch, and Yaw Angles

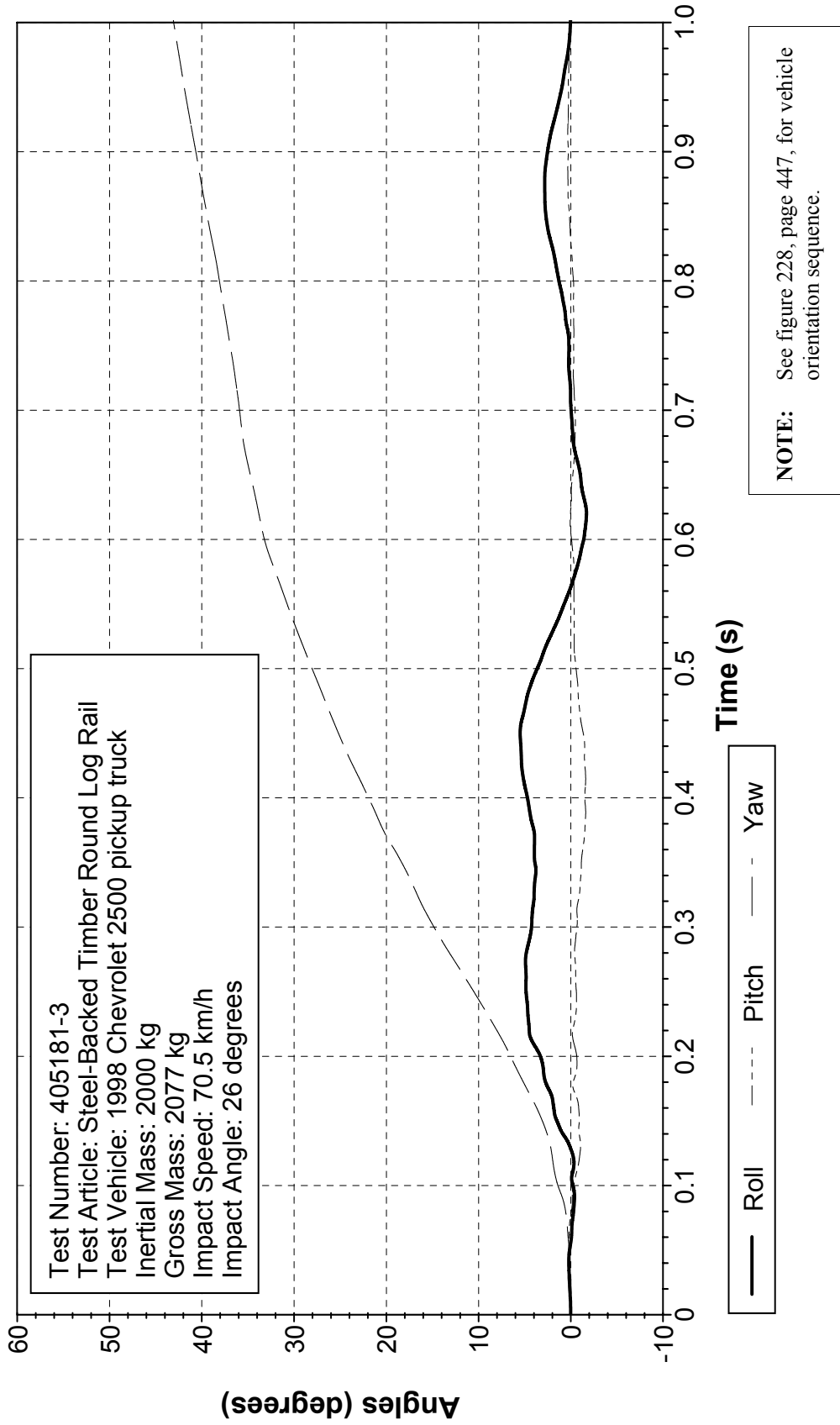

Figure 255. Vehicle angular displacements for test 405181-3.

# X Acceleration at C.G.

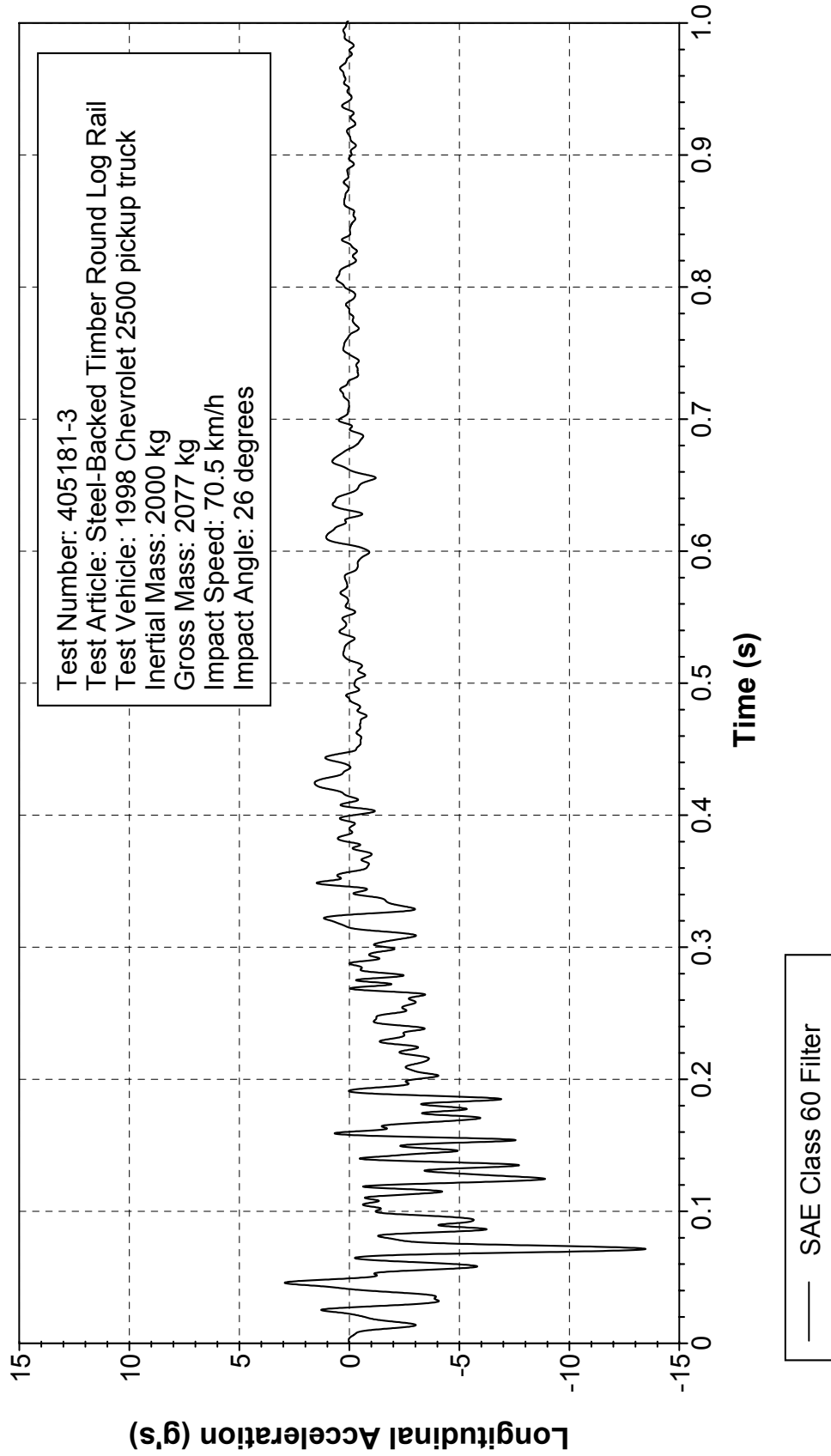

Figure 256. Vehicle longitudinal accelerometer trace for test 405181-3 (accelerometer located at center of gravity).

# Y Acceleration at C.G.

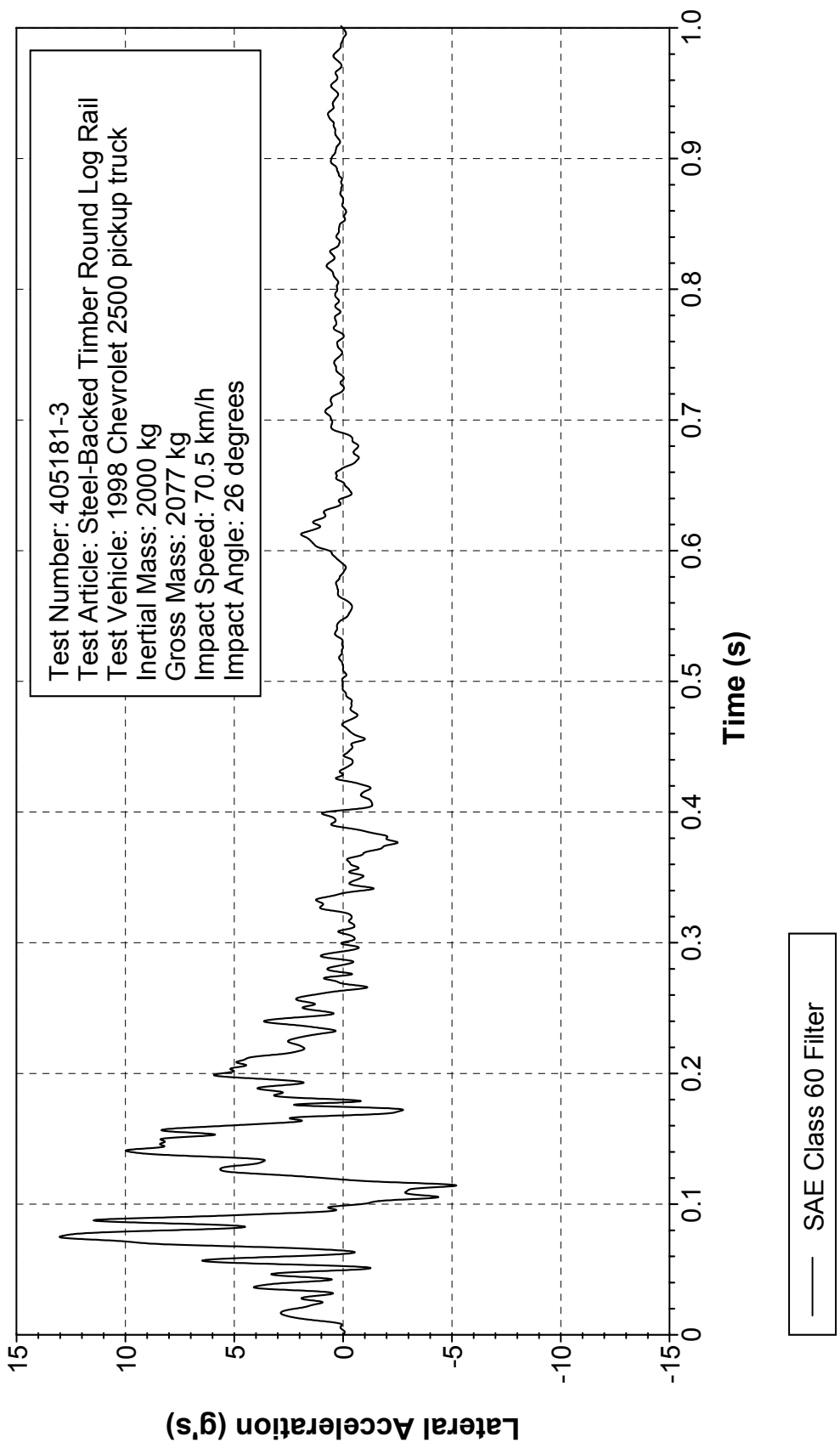

Figure 257. Vehicle lateral accelerometer trace for test 405181-3 (accelerometer located at center of gravity).



## Z Acceleration at C.G.

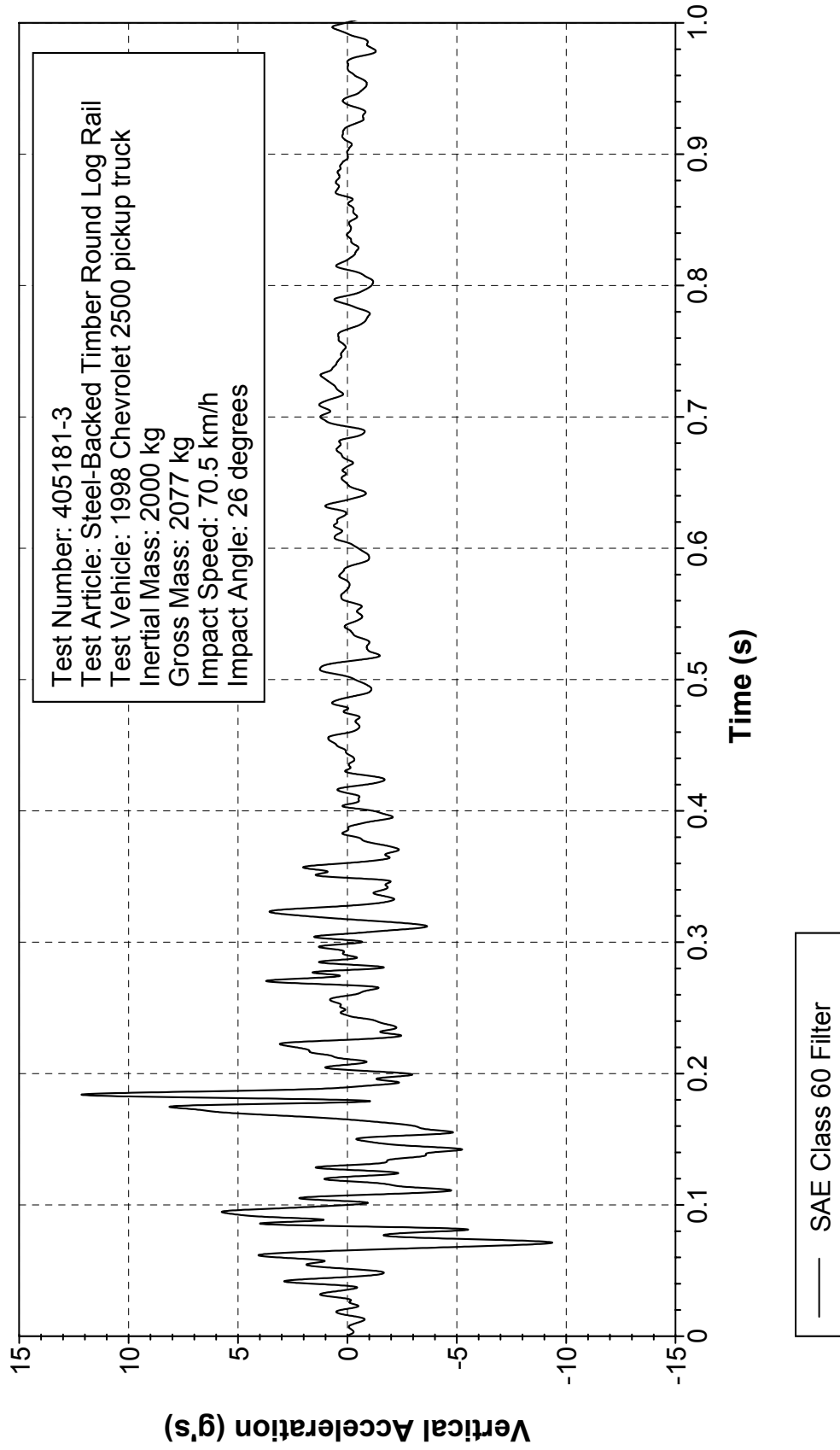

Figure 258. Vehicle vertical accelerometer trace for test 405181-3 (accelerometer located at center of gravity).

# X Acceleration over Rear Axle

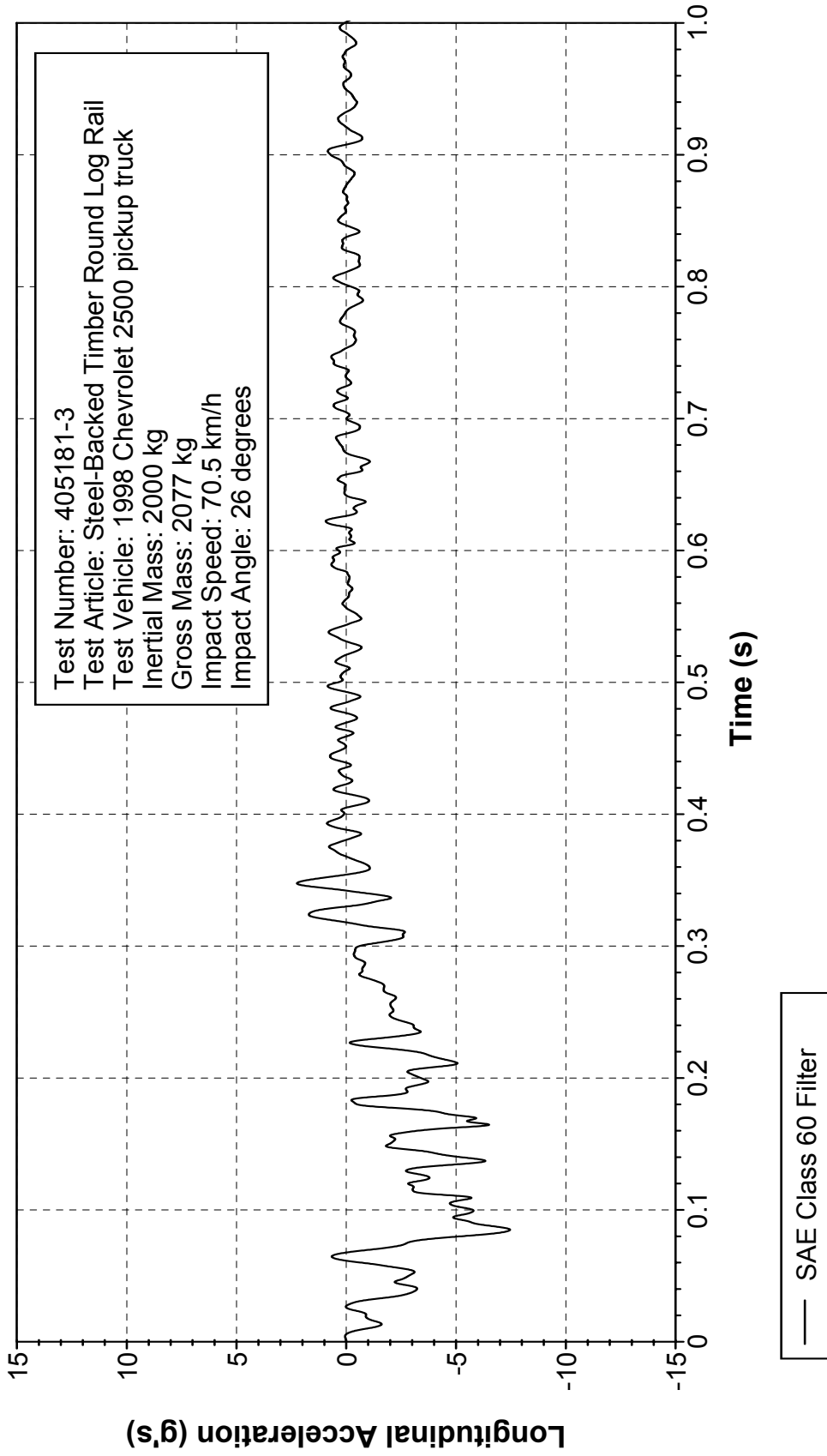

Figure 259. Vehicle longitudinal accelerometer trace for test 405181-3 (accelerometer located over rear axle).

# Y Acceleration over Rear Axle

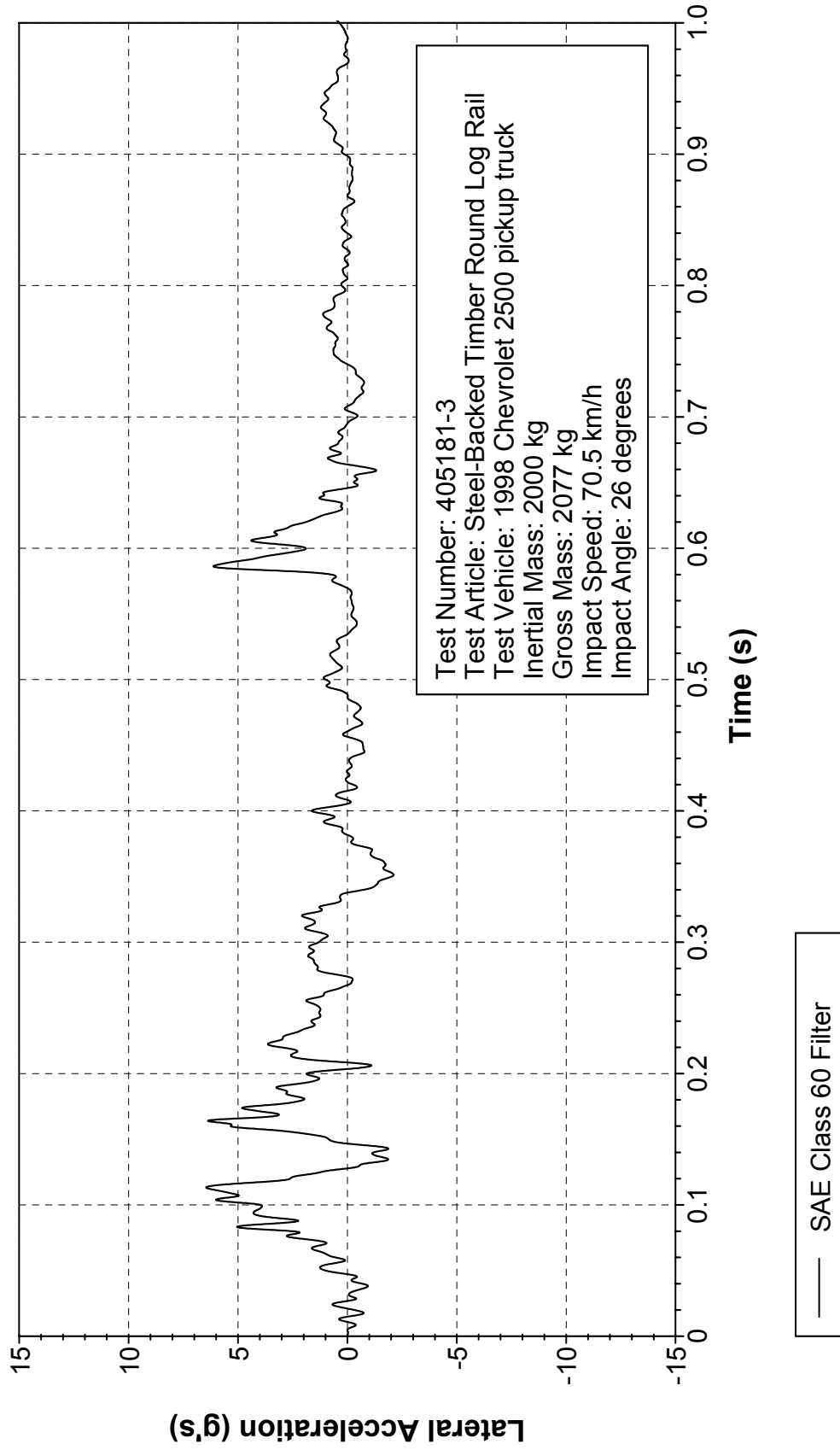

Figure 260. Vehicle lateral accelerometer trace for test 405181-3 (accelerometer located over rear axle).

# Z Acceleration over Rear Axle

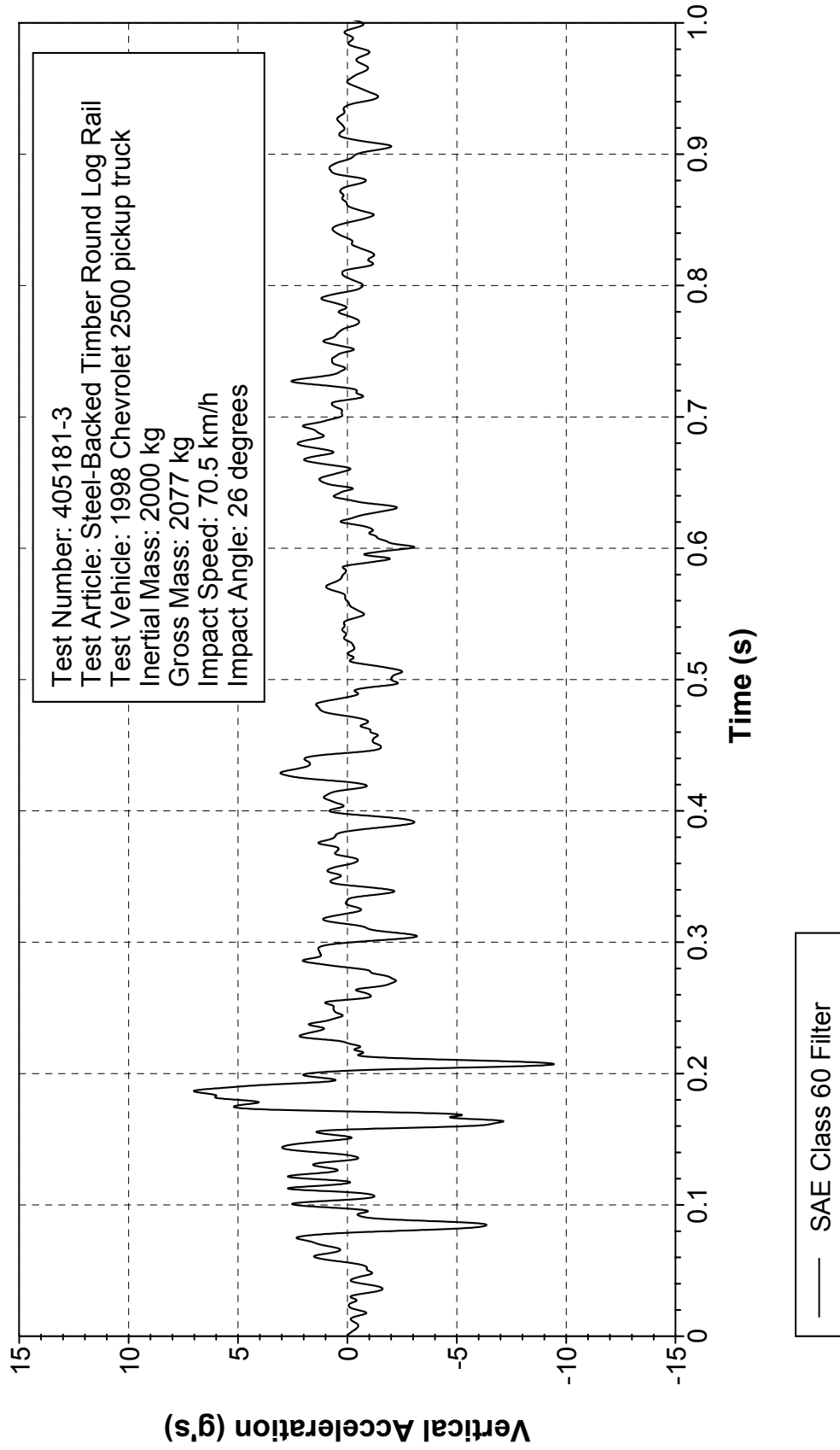

Figure 261. Vehicle vertical accelerometer trace for test 405181-3 (accelerometer located over rear axle).

### Crash Test 405181-3

#### Accelerometer on top of instrument panel surface

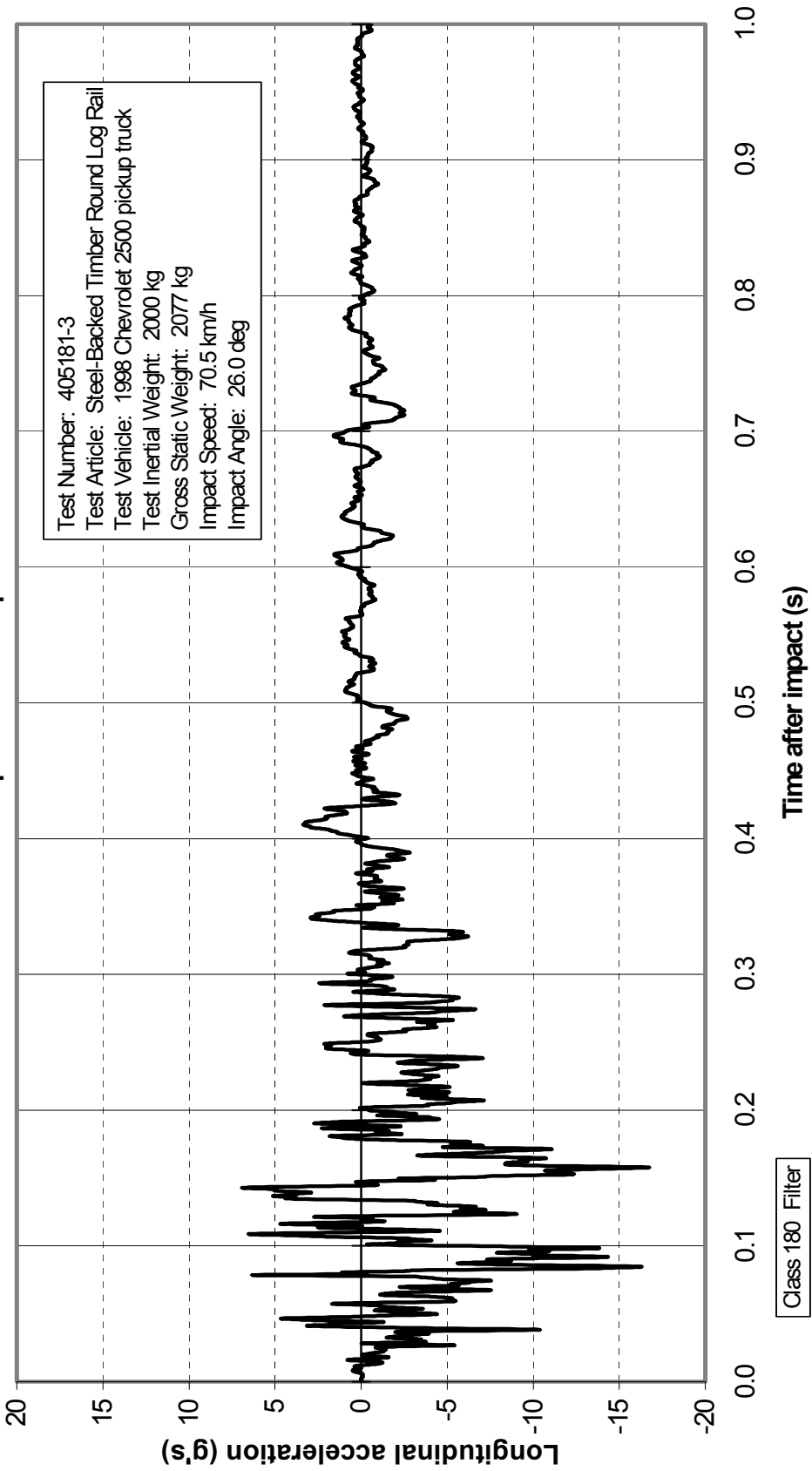

Figure 262. Vehicle longitudinal accelerometer trace for test 405181-3 (accelerometer located on top surface of instrument panel).

### Crash Test 405181-3

#### Accelerometer on right front brake caliper

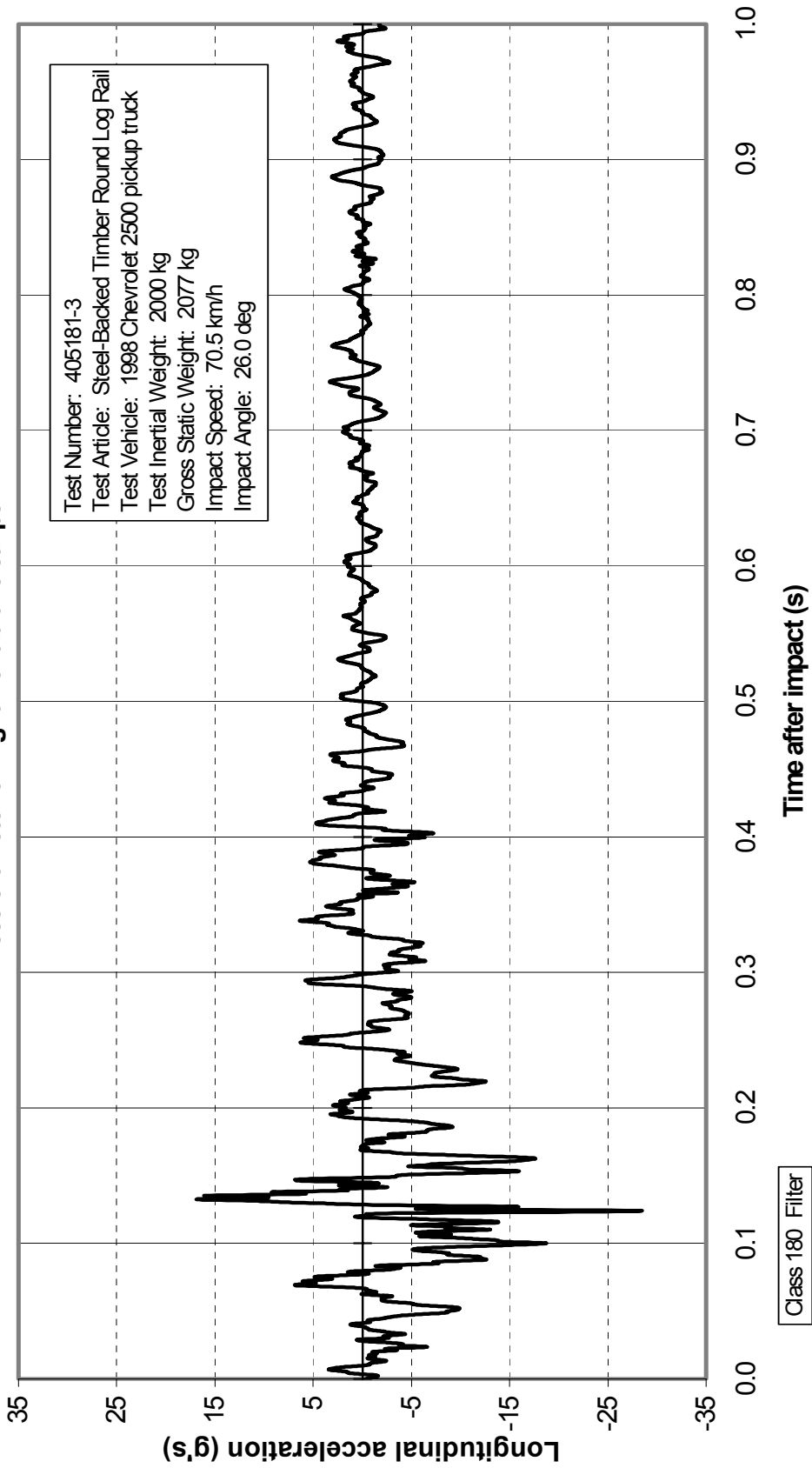

Figure 263. Vehicle lateral accelerometer trace for test 405181-3 (accelerometer located on right front brake caliper).

### Crash Test 405181-3

Accelerometer on left front brake caliper

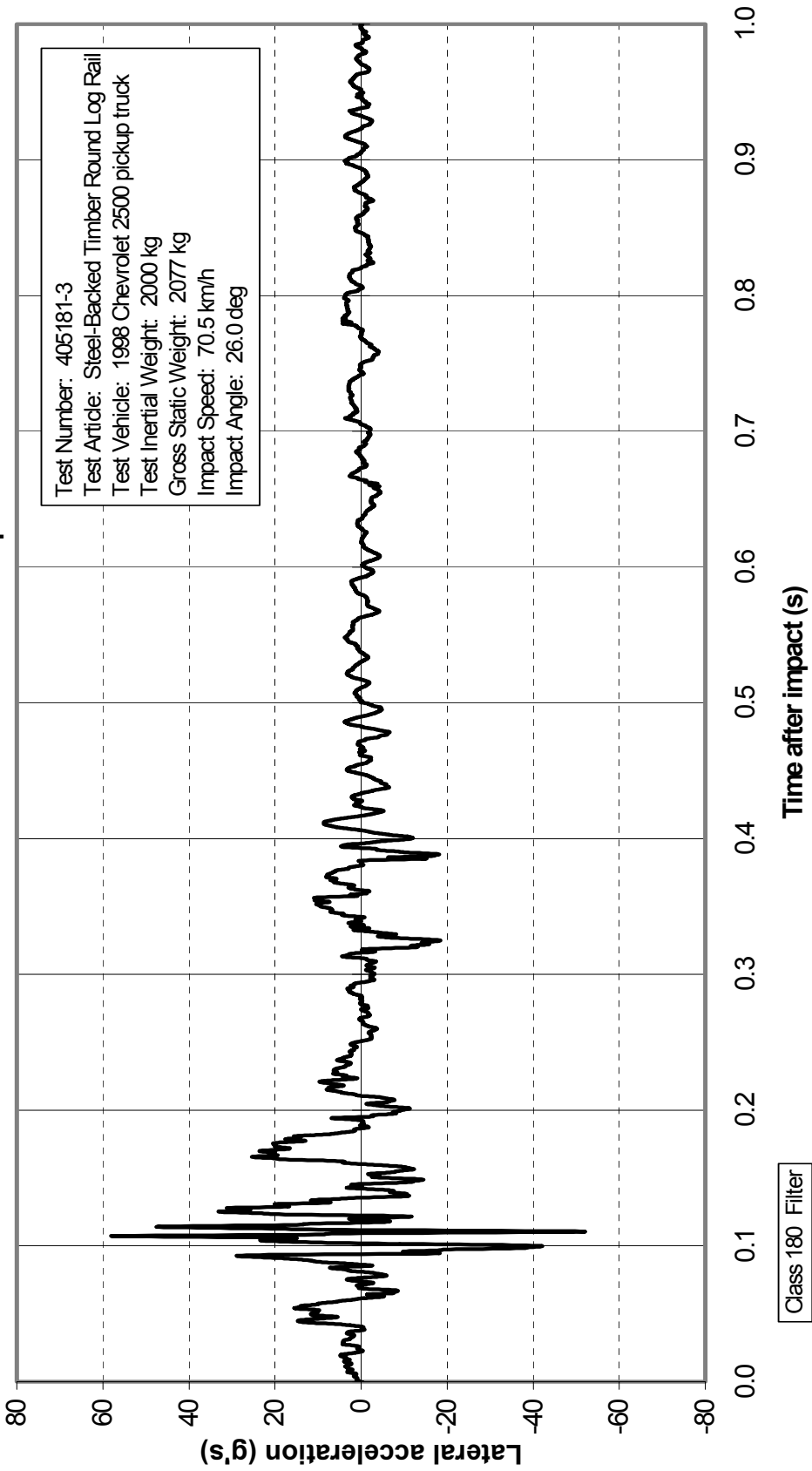

Figure 264. Vehicle longitudinal accelerometer trace for test 405181-3 (accelerometer located on left front brake caliper).

### Crash Test 405181-3 Accelerometer on top of engine block

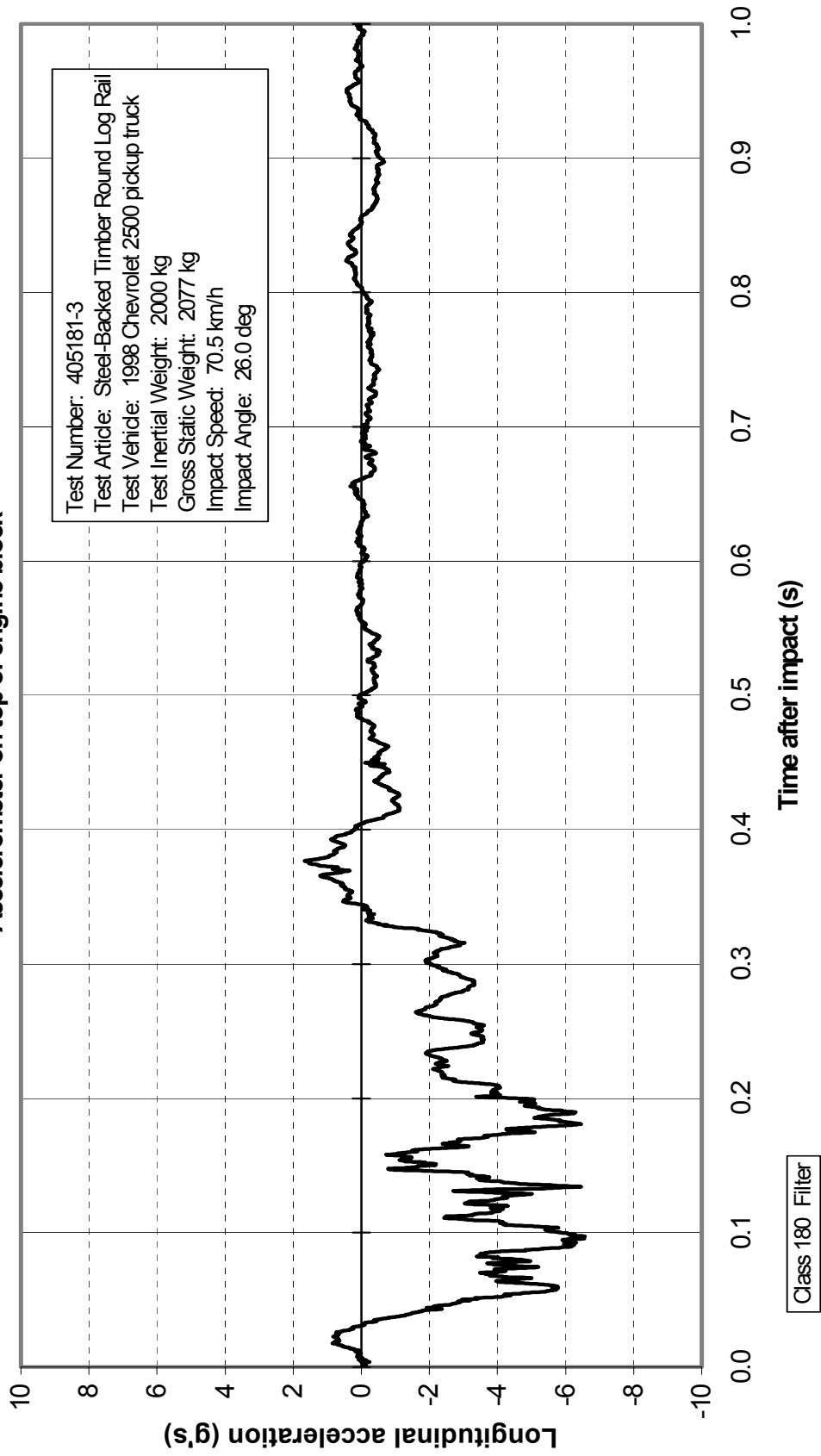

Figure 265. Vehicle longitudinal accelerometer trace for test 405181-3 (accelerometer located on top of engine block).



### Crash Test 405181-3

Accelerometer on bottom of engine block

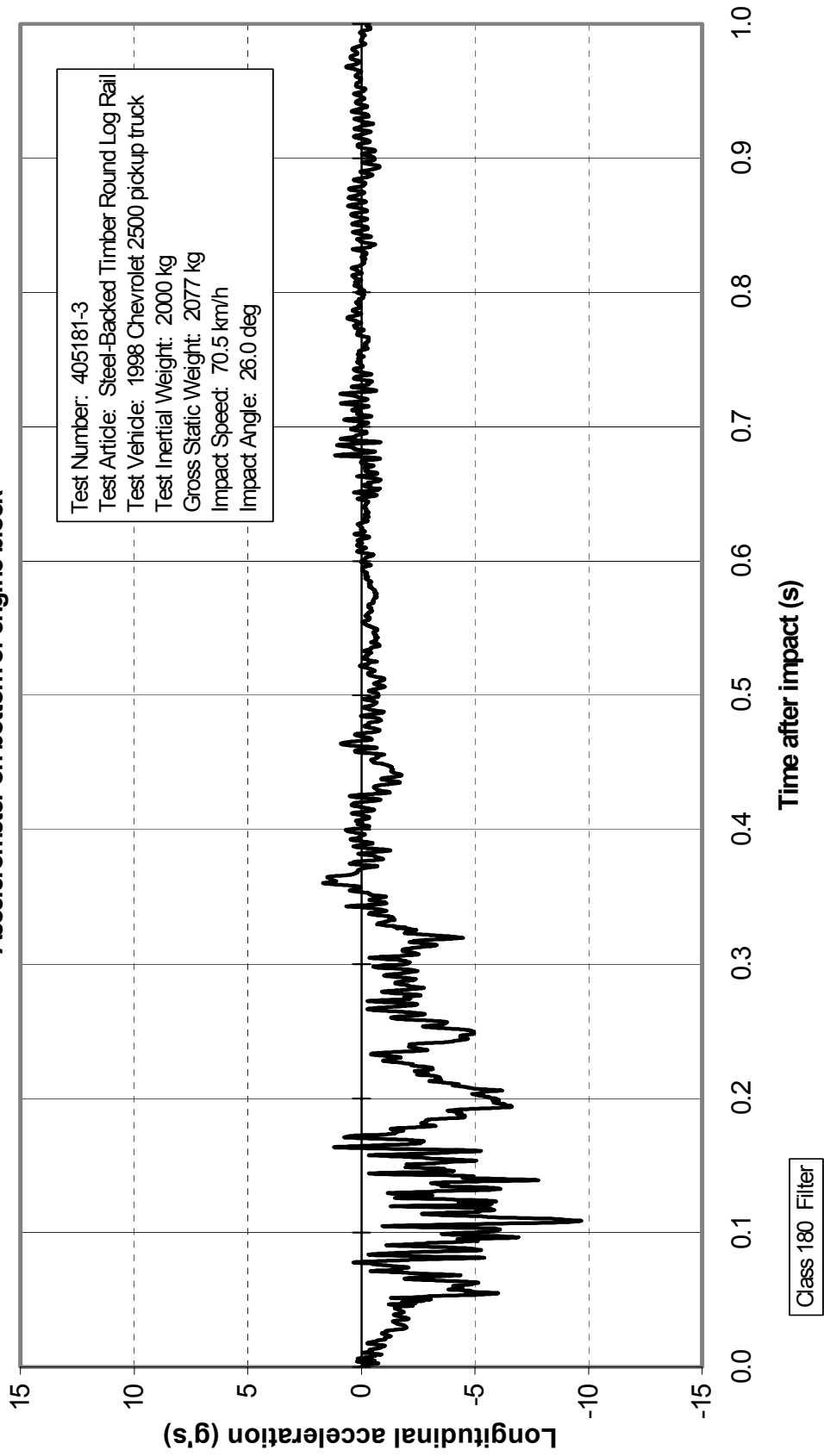

Figure 266. Vehicle longitudinal accelerometer trace for test 405181-3 (accelerometer located on bottom of engine block).

# Roll, Pitch, and Yaw Angles

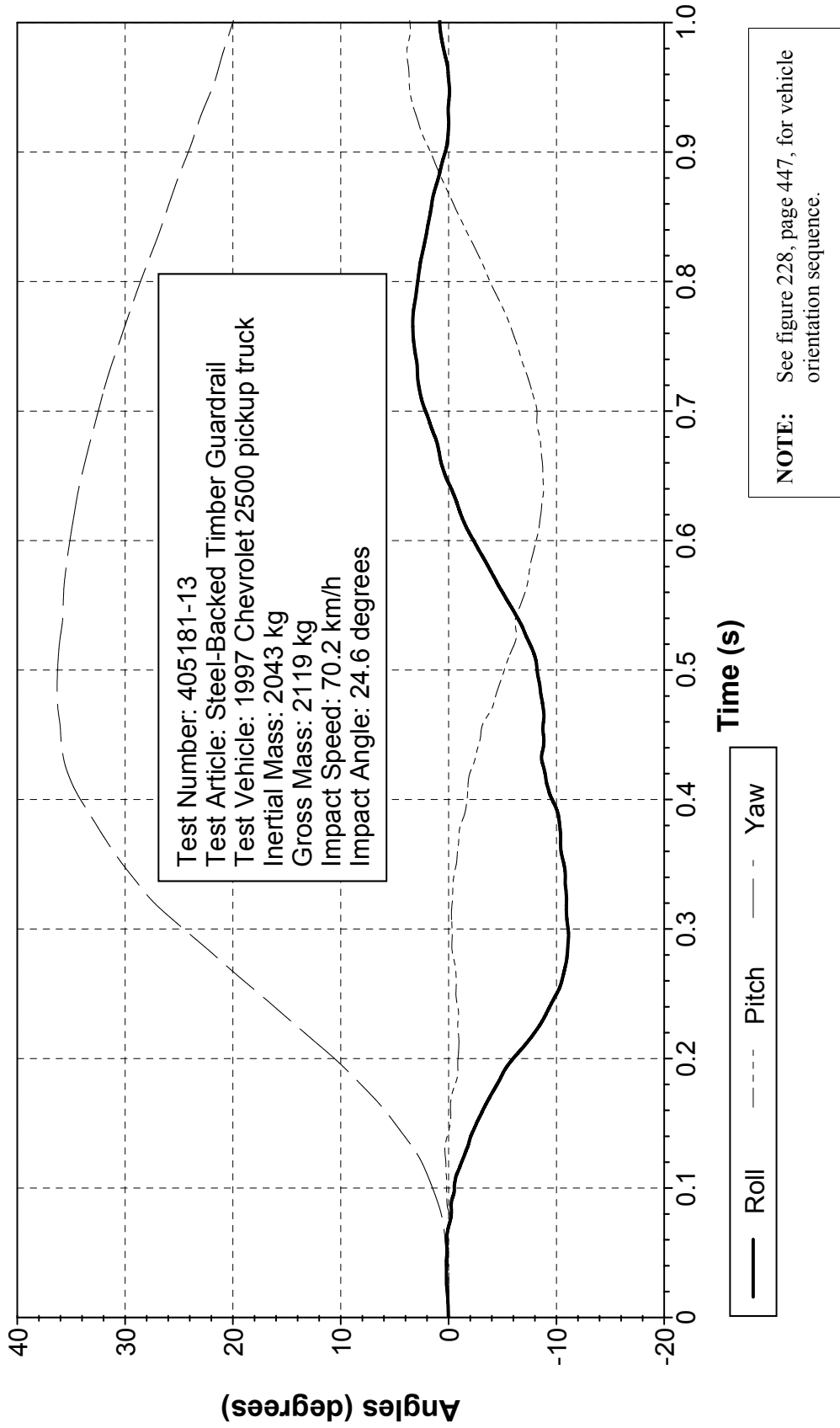

Figure 267. Vehicle angular displacements for test 405181-13.

# X Acceleration at C.G.

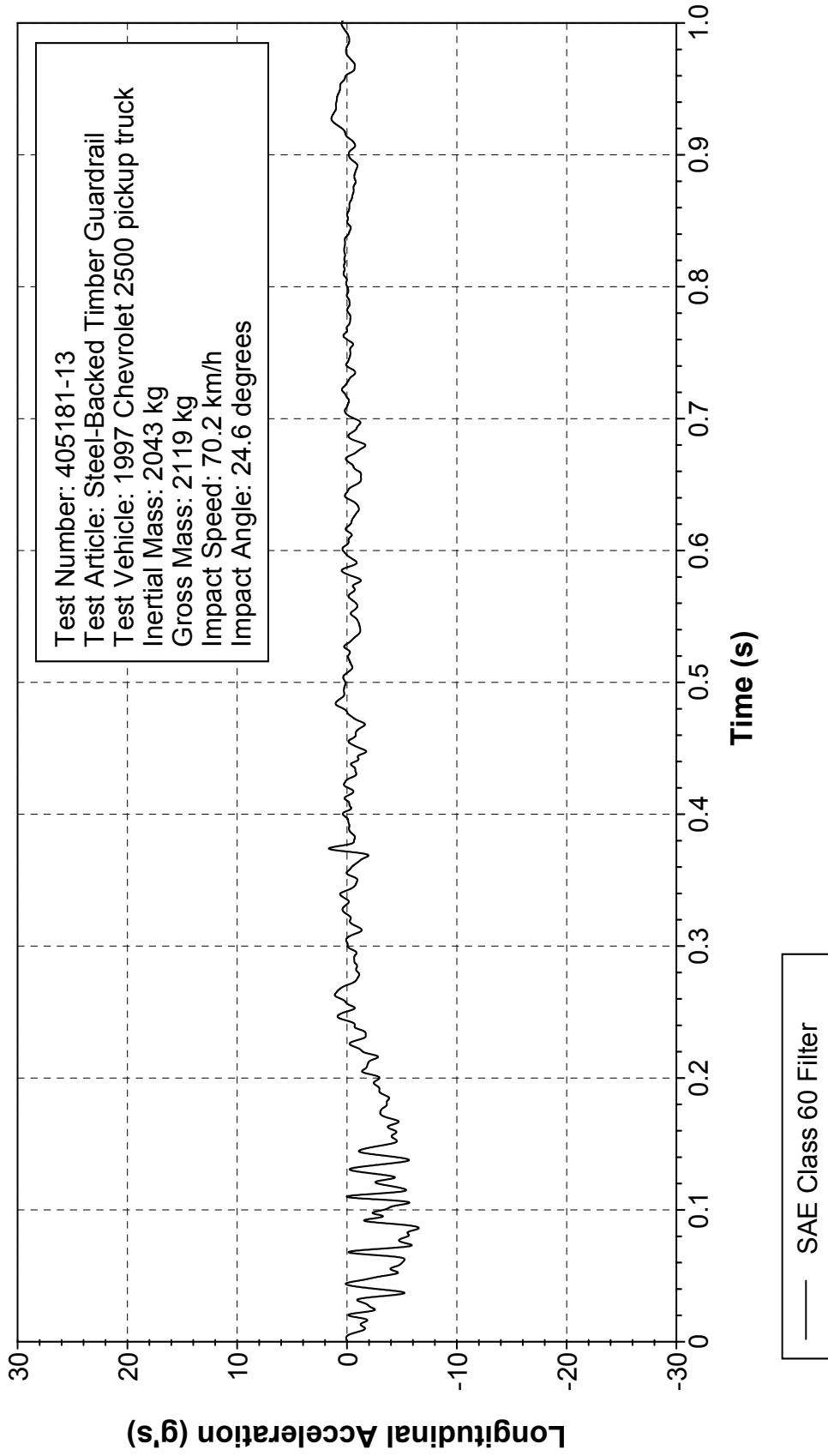

Figure 268. Vehicle longitudinal accelerometer trace for test 405181-13 (accelerometer located at center of gravity).

# Y Acceleration at C.G.

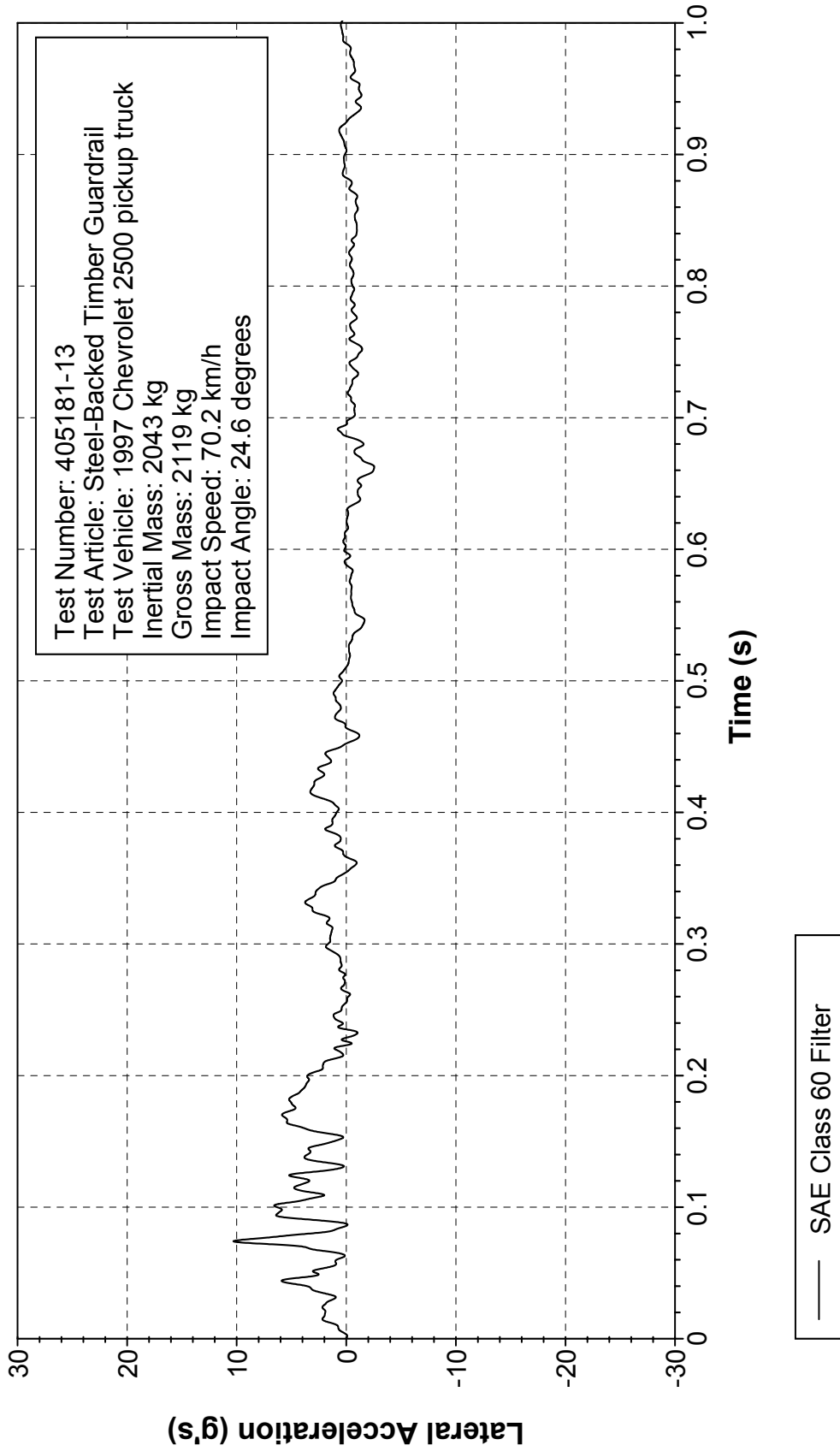

Figure 269. Vehicle lateral accelerometer trace for test 405181-13 (accelerometer located at center of gravity).

## Z Acceleration at C.G.

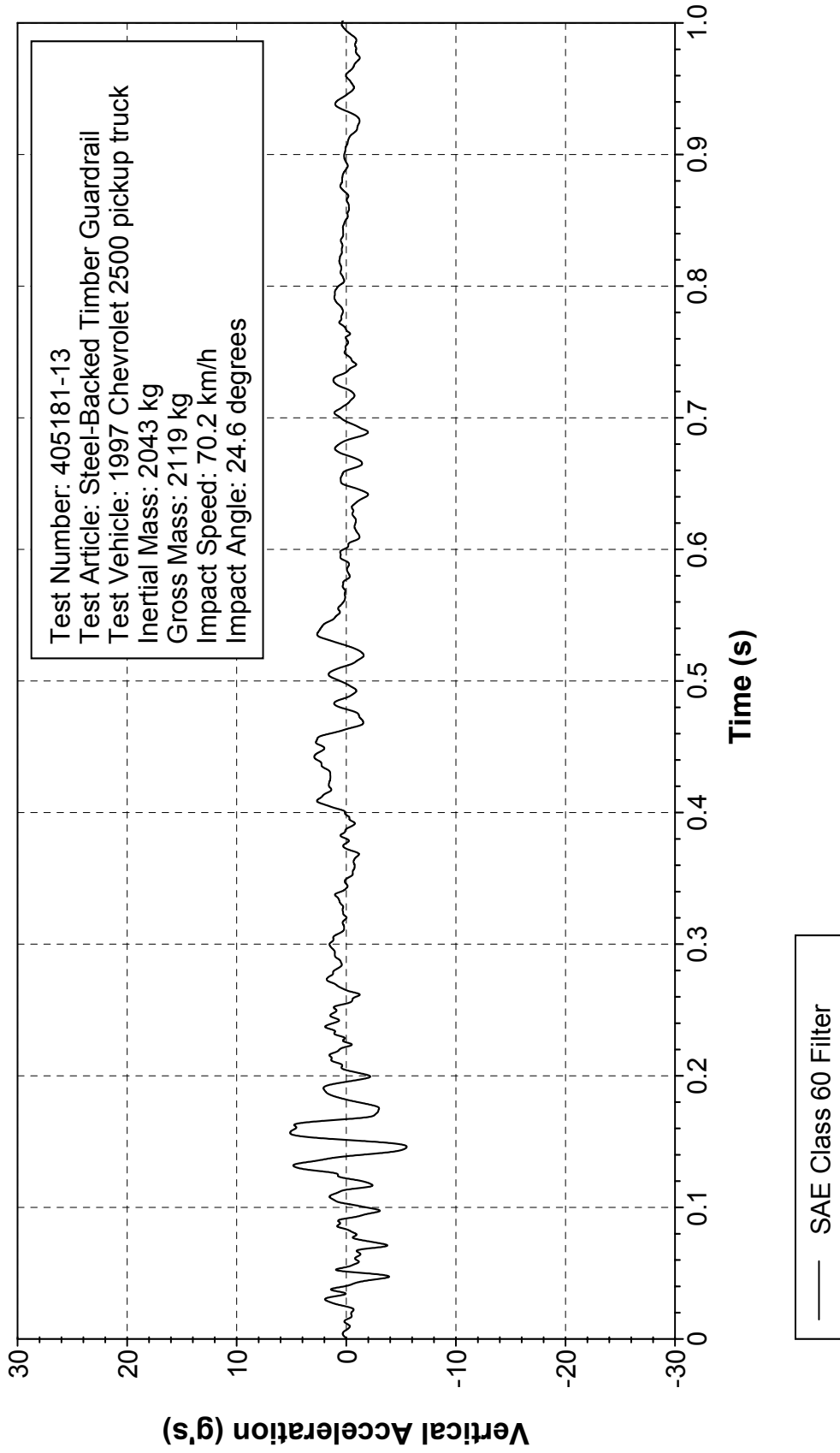

Figure 270. Vehicle vertical accelerometer trace for test 405181-13 (accelerometer located at center of gravity).

# X Acceleration over Rear Axle

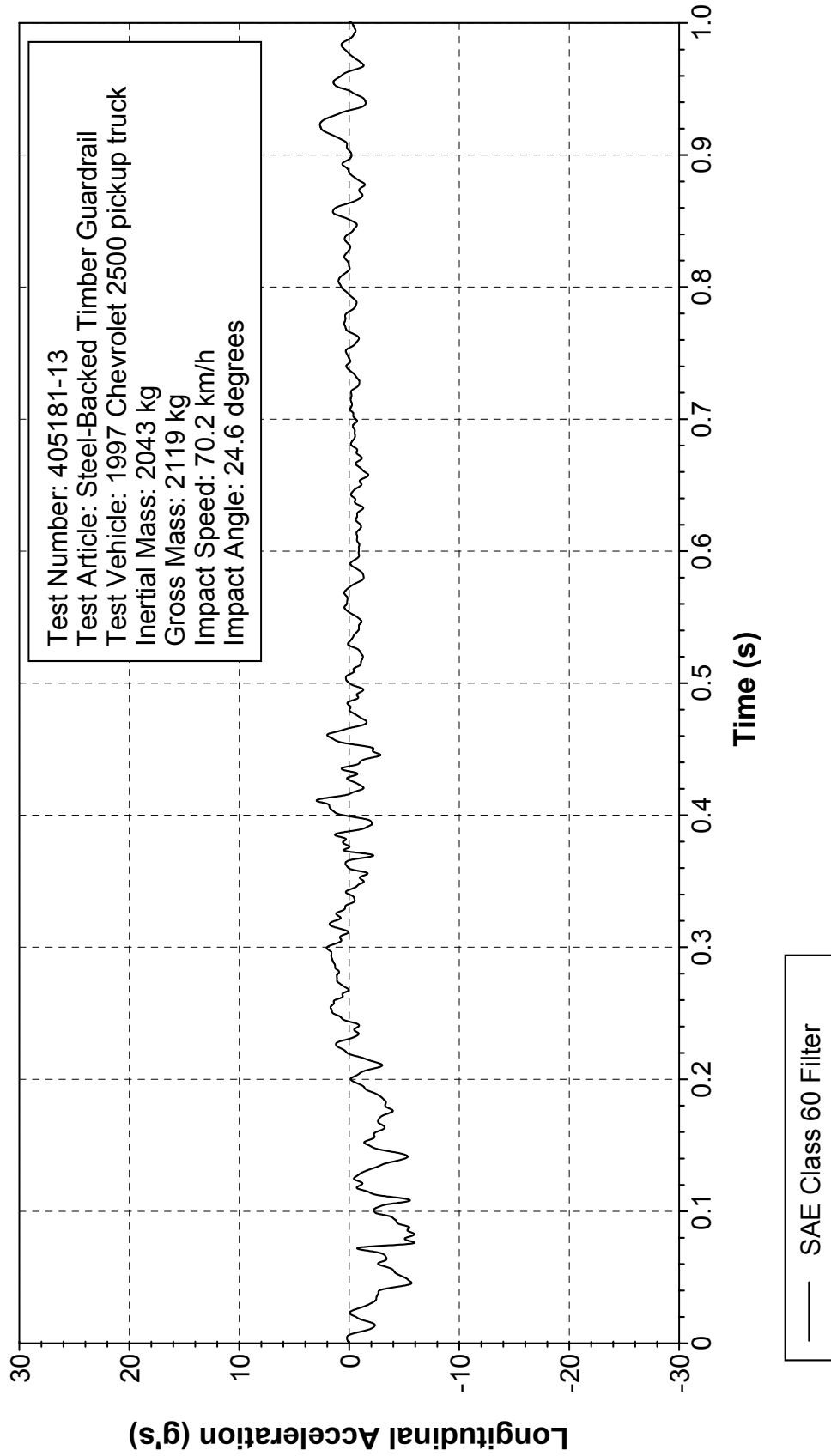

Figure 271. Vehicle longitudinal accelerometer trace for test 405181-13 (accelerometer located over rear axle).

# Y Acceleration over Rear Axle

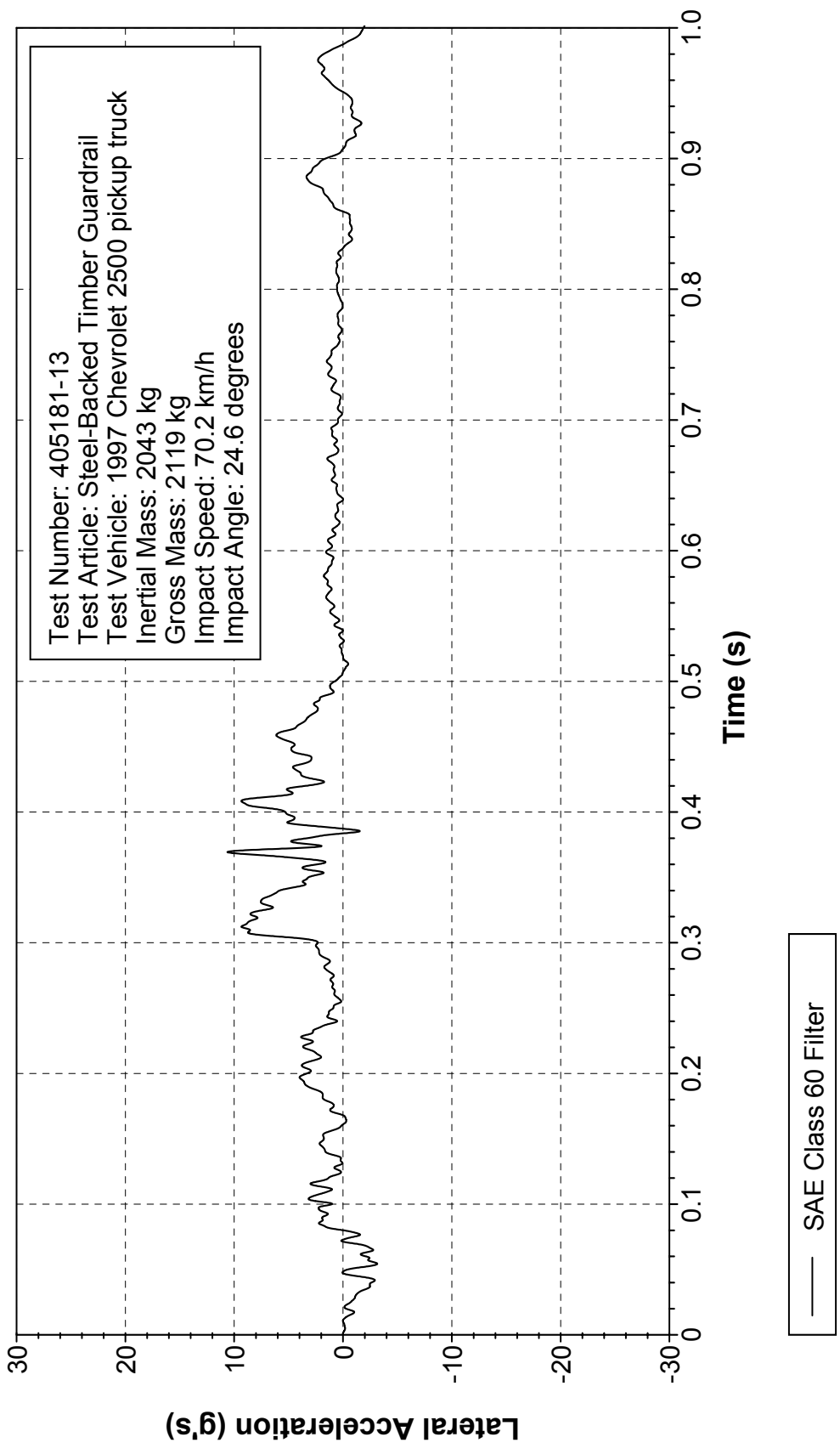

Figure 272. Vehicle lateral accelerometer trace for test 405181-13 (accelerometer located over rear axle).

# Z Acceleration over Rear Axle

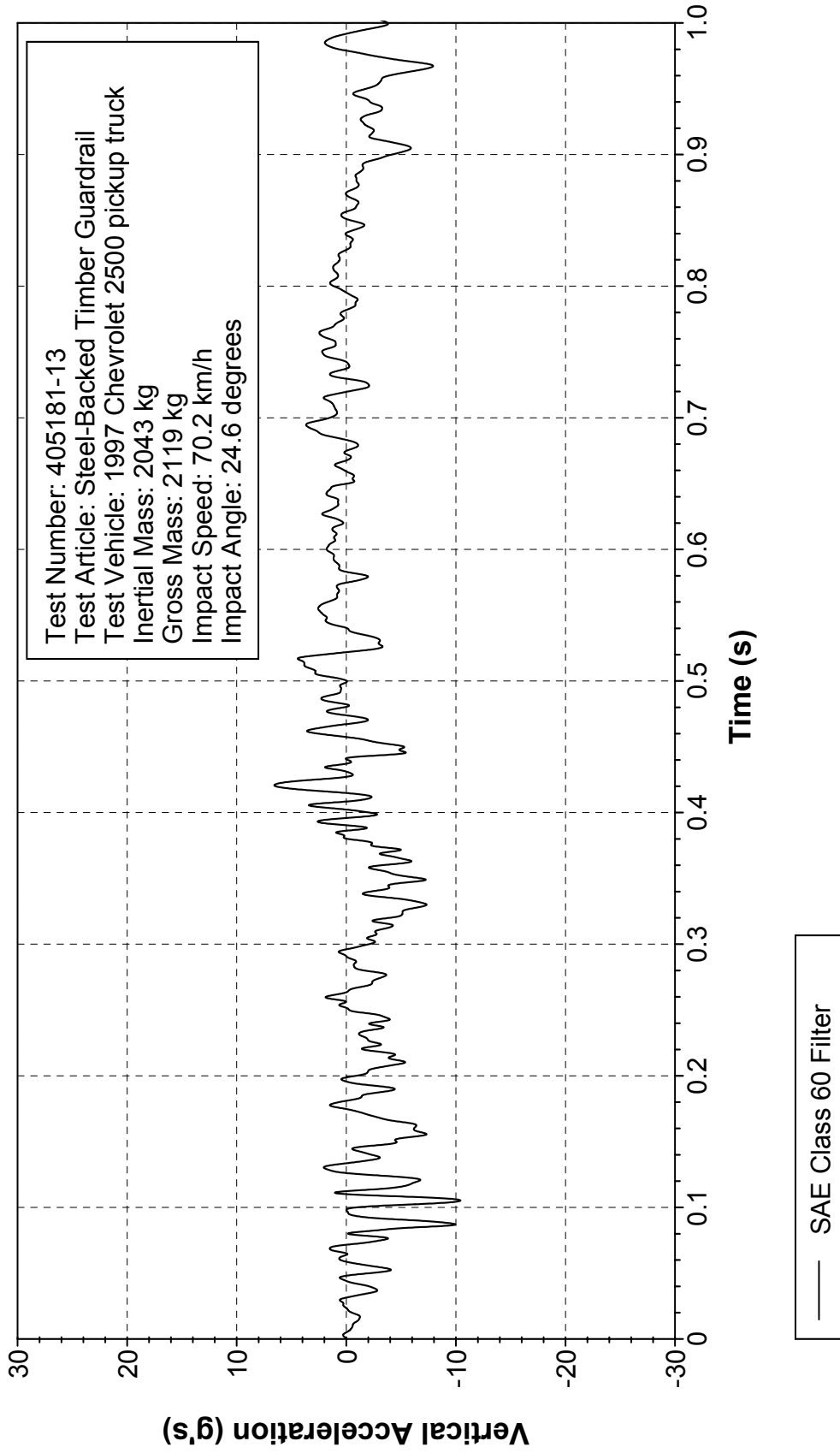

Figure 273. Vehicle vertical accelerometer trace for test 405181-13 (accelerometer located over rear axle).



# Roll, Pitch, and Yaw Angles

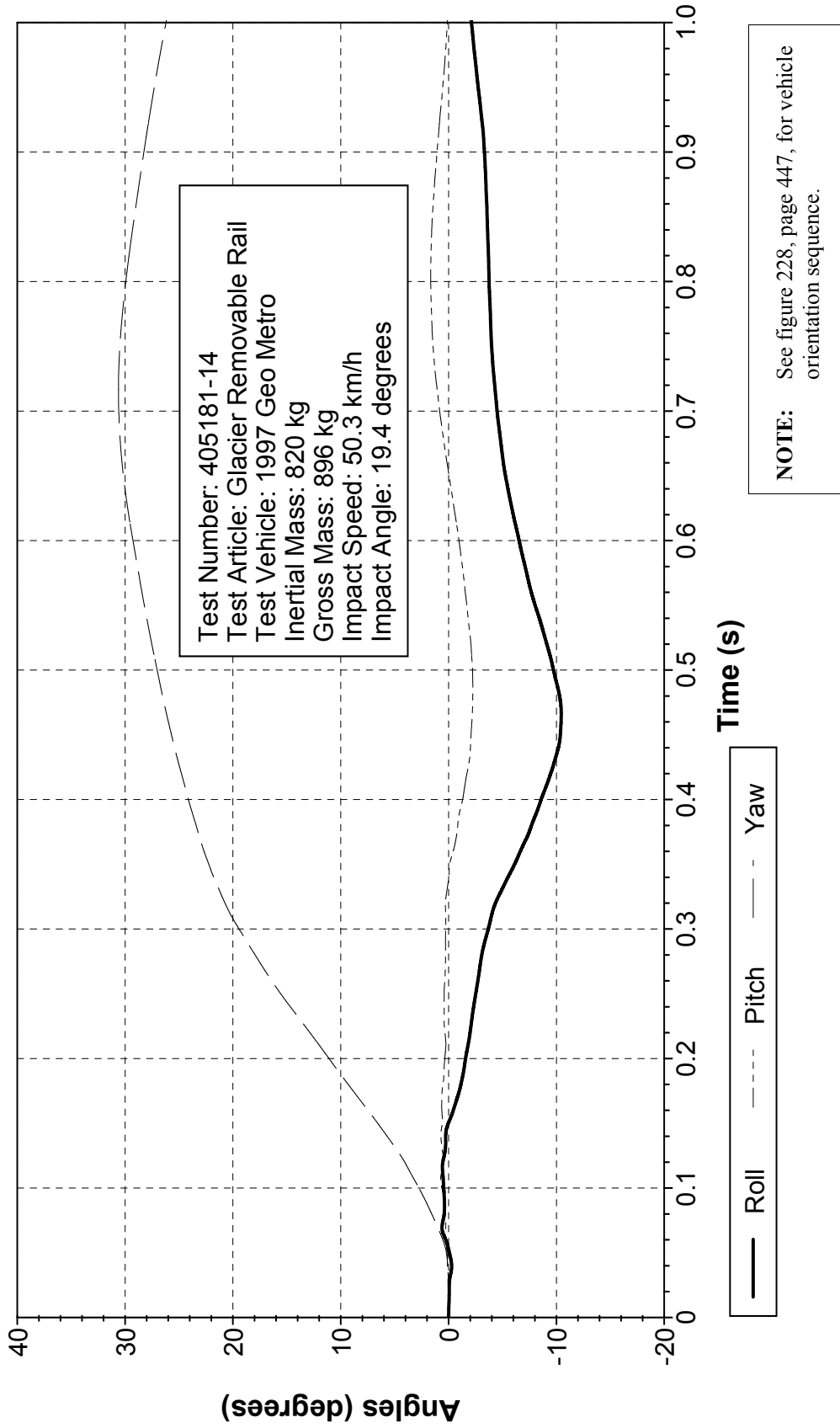

Figure 274. Vehicle angular displacements for test 405181-14.

# X Acceleration at C.G.

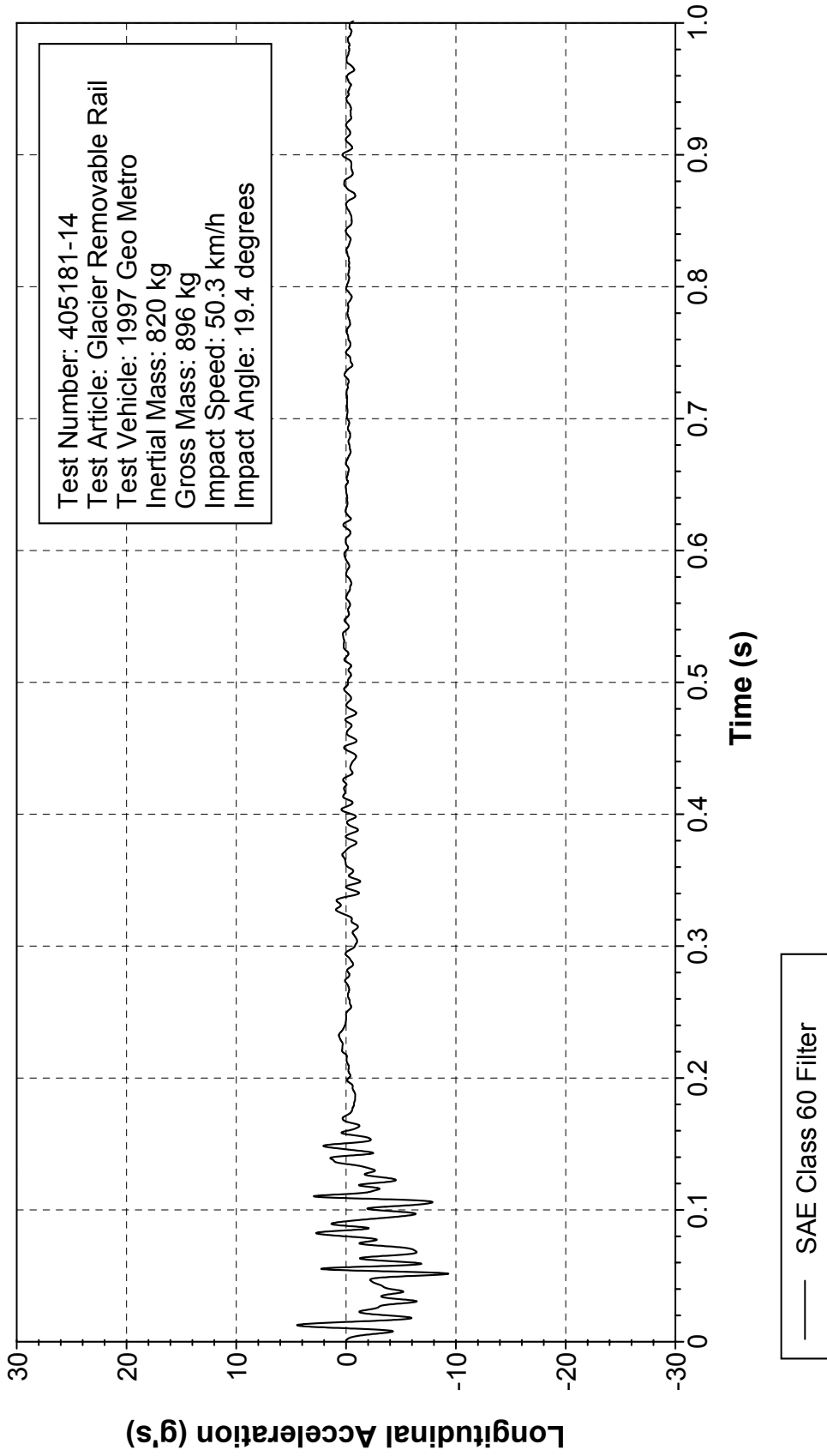

Figure 275. Vehicle longitudinal accelerometer trace for test 405181-14 (accelerometer located at center of gravity).

# Y Acceleration at C.G.

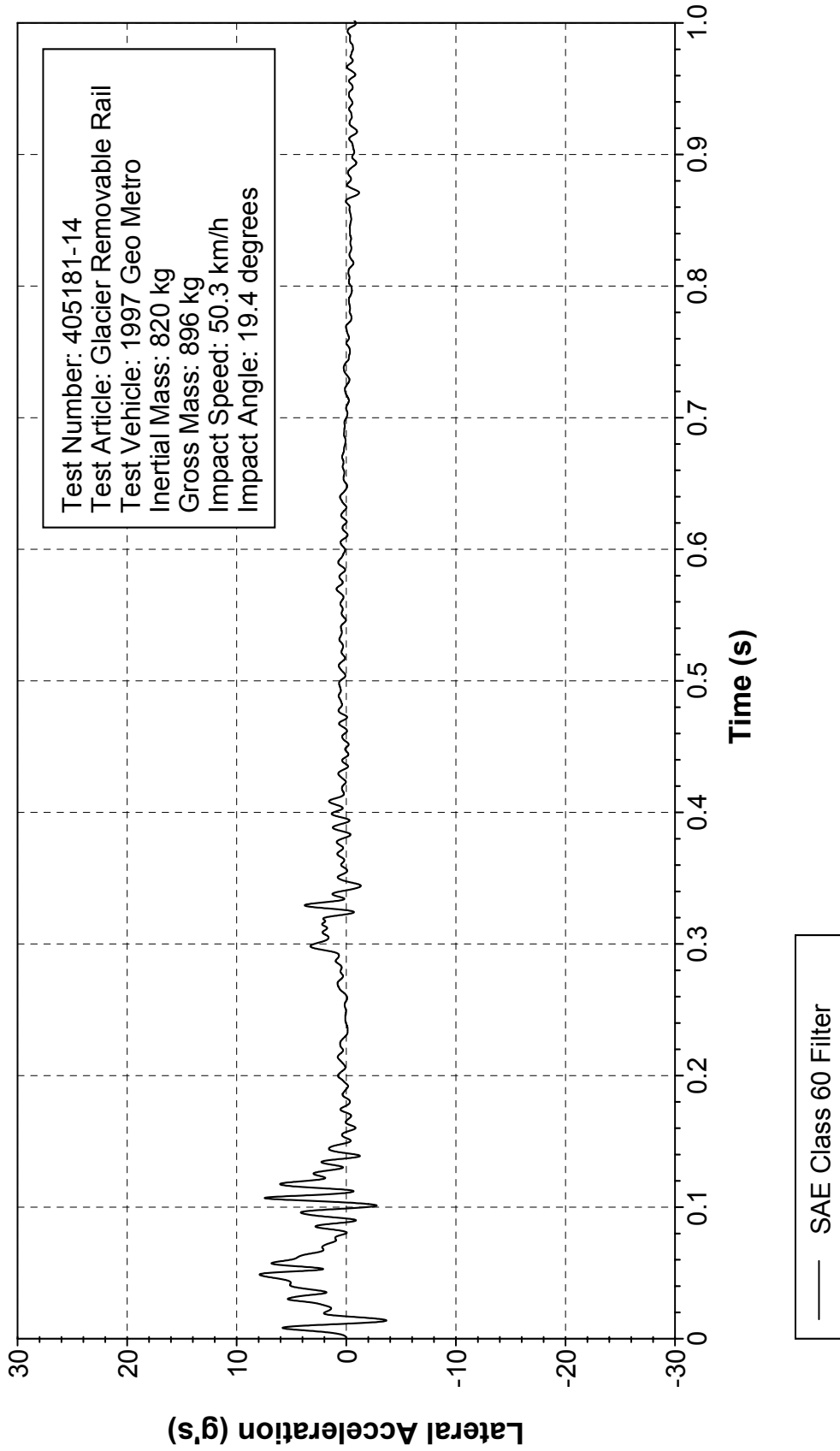

Figure 276. Vehicle lateral accelerometer trace for test 405181-14 (accelerometer located at center of gravity).

# Z Acceleration at C.G.

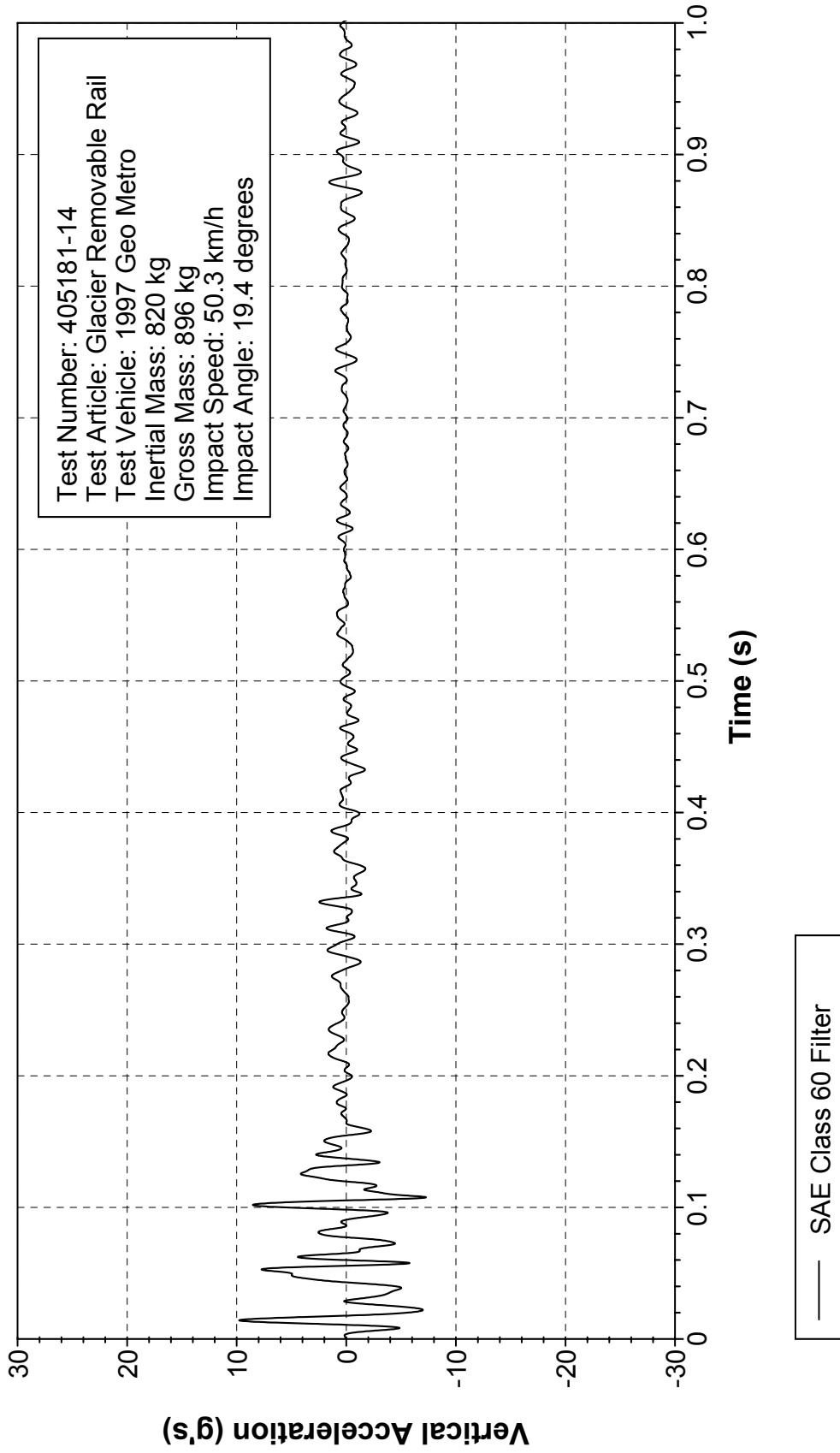

Figure 277. Vehicle vertical accelerometer trace for test 405181-14 (accelerometer located at center of gravity).

# X Acceleration over Rear Axle

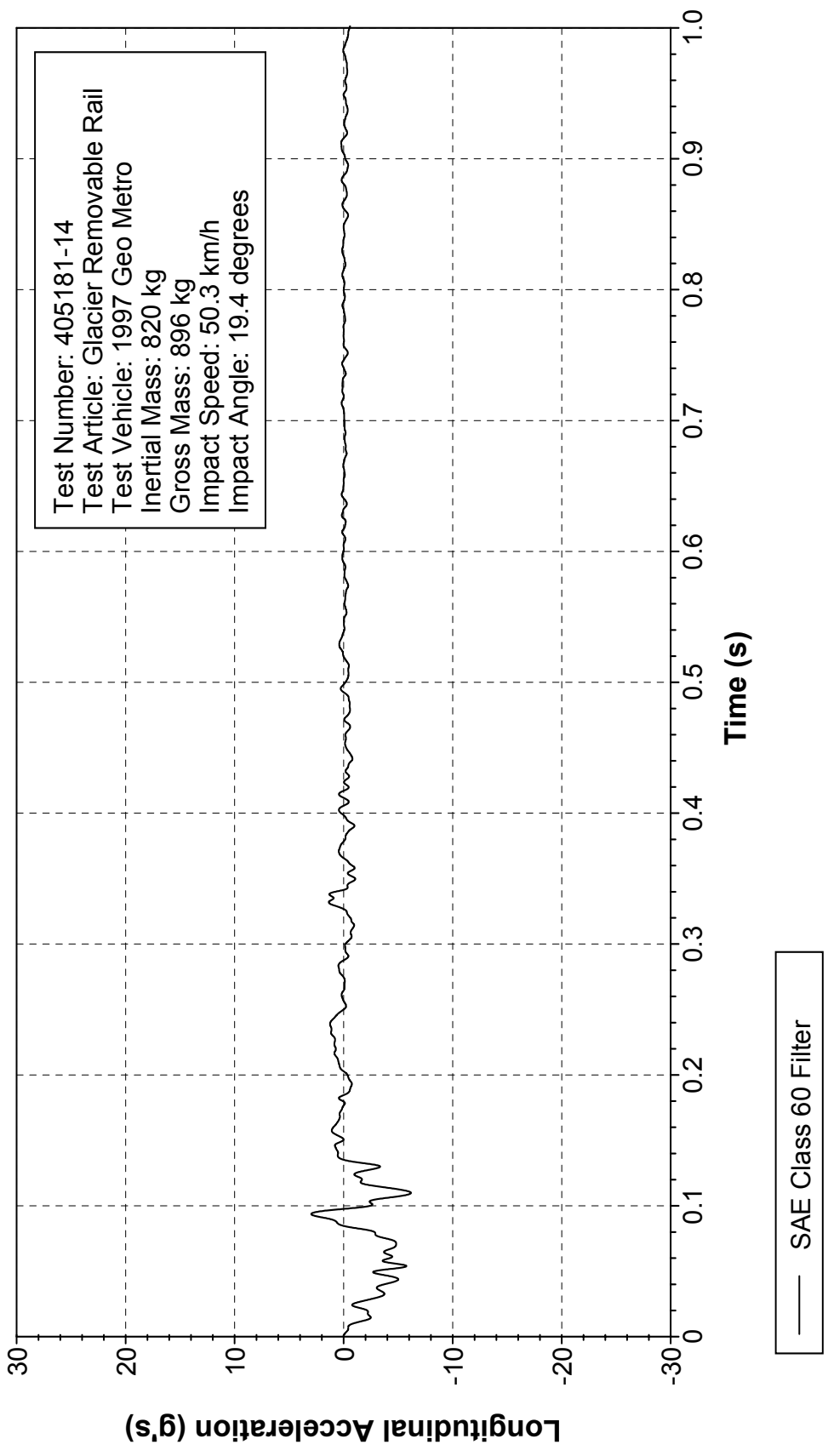

Figure 278. Vehicle longitudinal accelerometer trace for test 405181-14 (accelerometer located over rear axle).

# Y Acceleration over Rear Axle

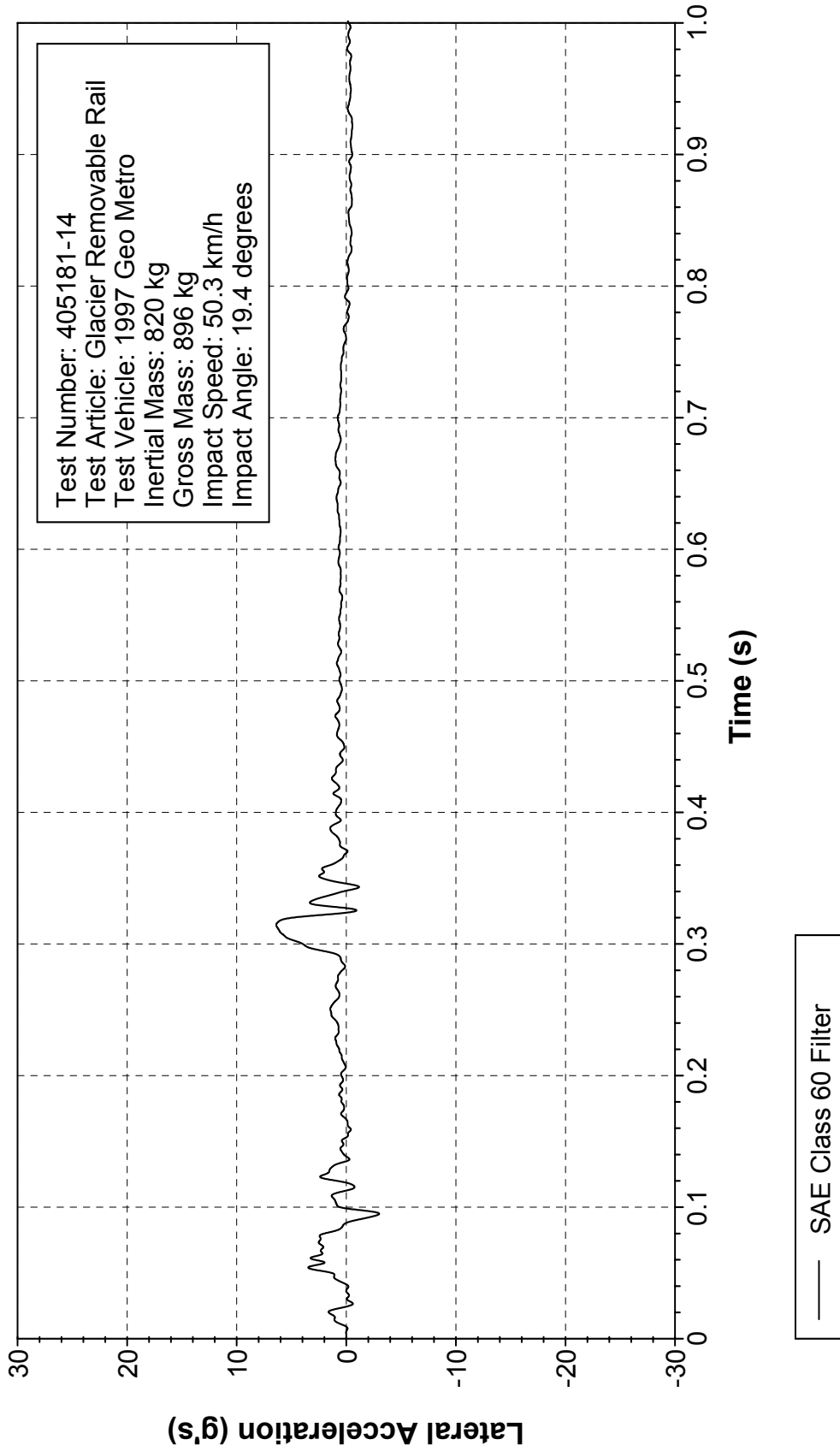

Figure 279. Vehicle lateral accelerometer trace for test 405181-14 (accelerometer located over rear axle).

# Z Acceleration over Rear Axle

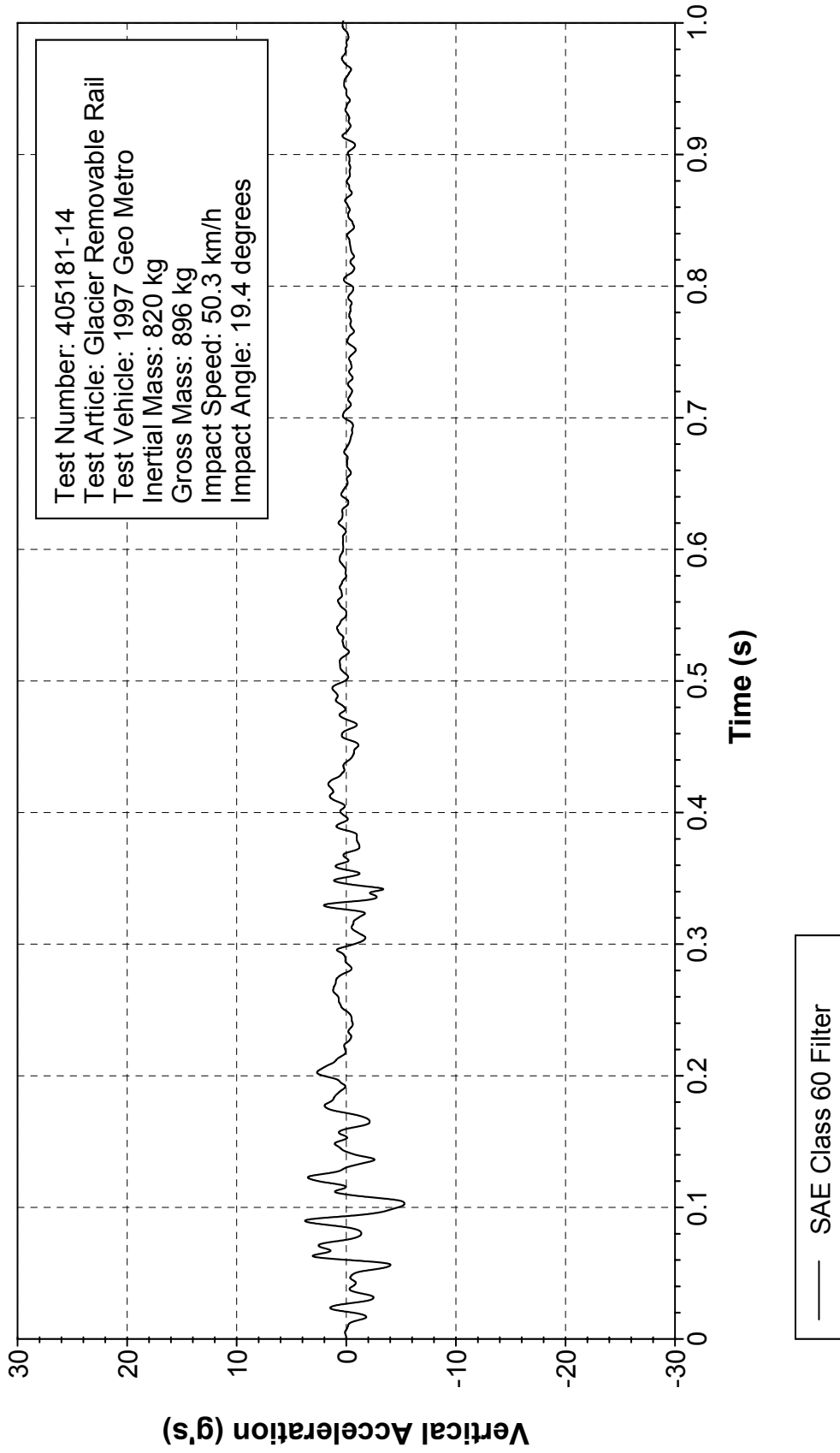

Figure 280. Vehicle vertical accelerometer trace for test 405181-14 (accelerometer located over rear axle).

**Crash Test 405181-14**  
Accelerometer on top of instrument panel surface

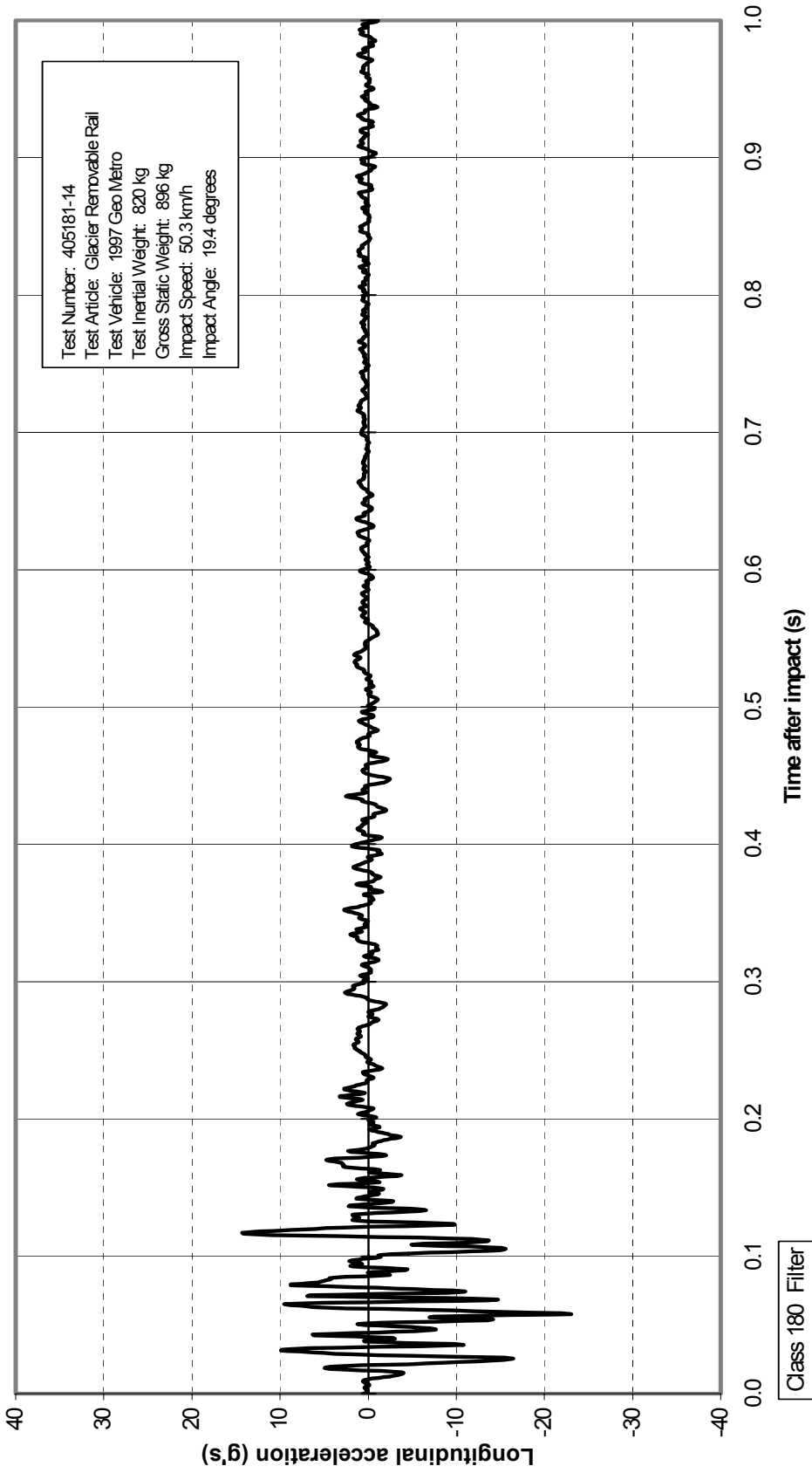

Figure 281. Vehicle longitudinal accelerometer trace for test 405181-14 (accelerometer located on top surface of instrument panel).



**Crash Test 405181-14**  
**Accelerometer on right front brake caliper**

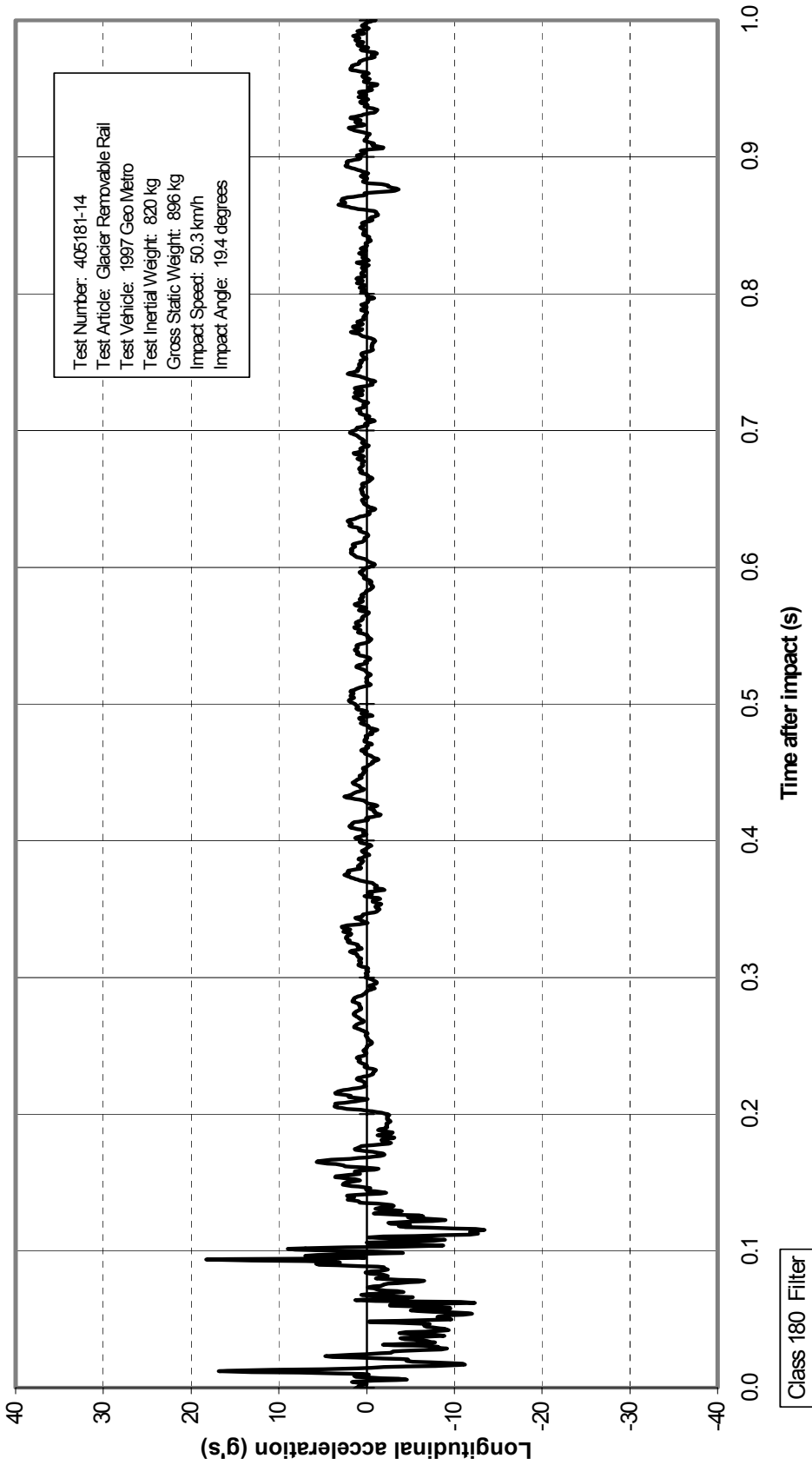

Figure 282. Vehicle lateral accelerometer trace for test 405181-14  
(accelerometer located on right front brake caliper).

**Crash Test 405181-14**  
Accelerometer on left front brake caliper

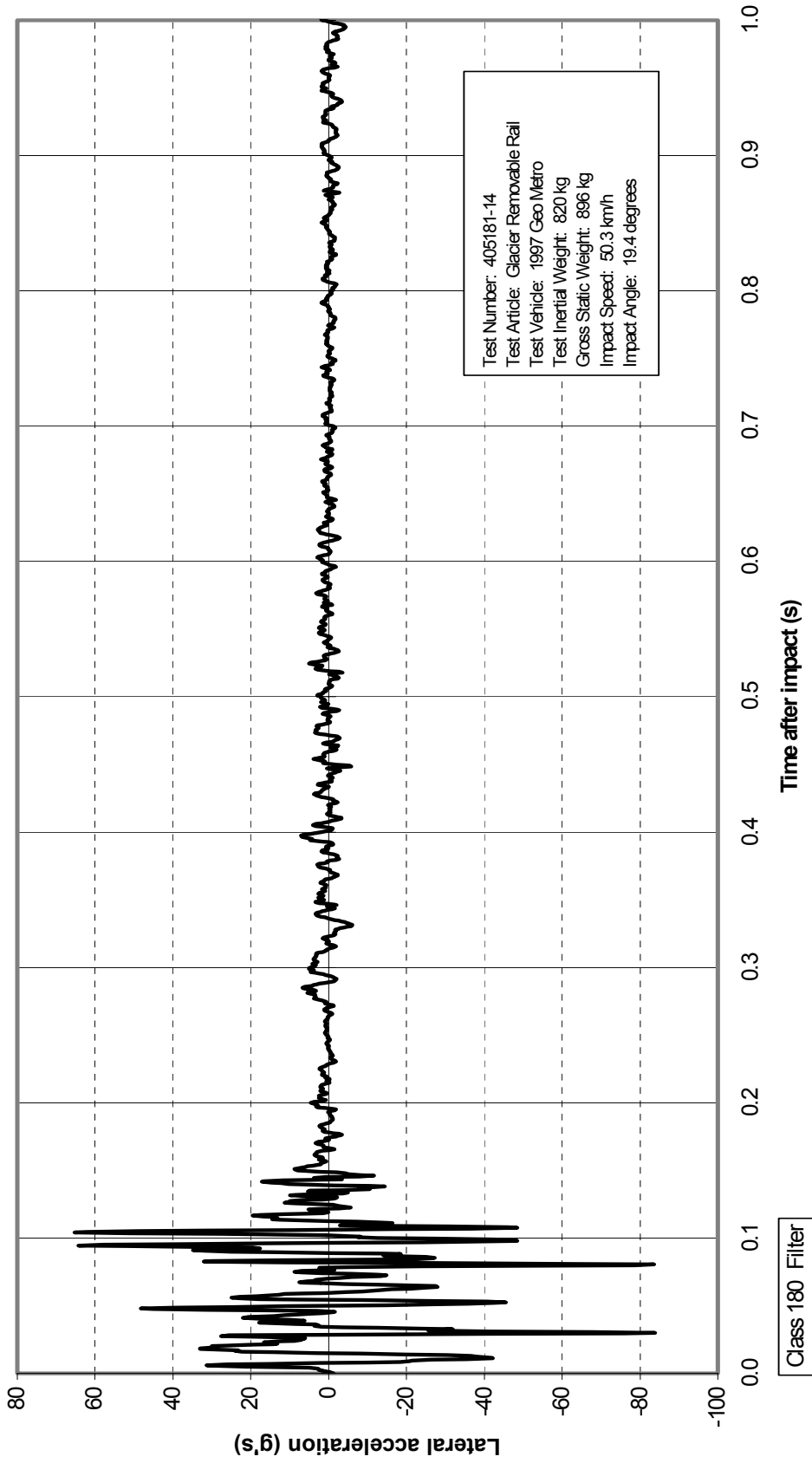

Figure 283. Vehicle longitudinal accelerometer trace for test 405181-14 (accelerometer located on left front brake caliper).

**Crash Test 405181-14**  
**Accelerometer on top of engine block**

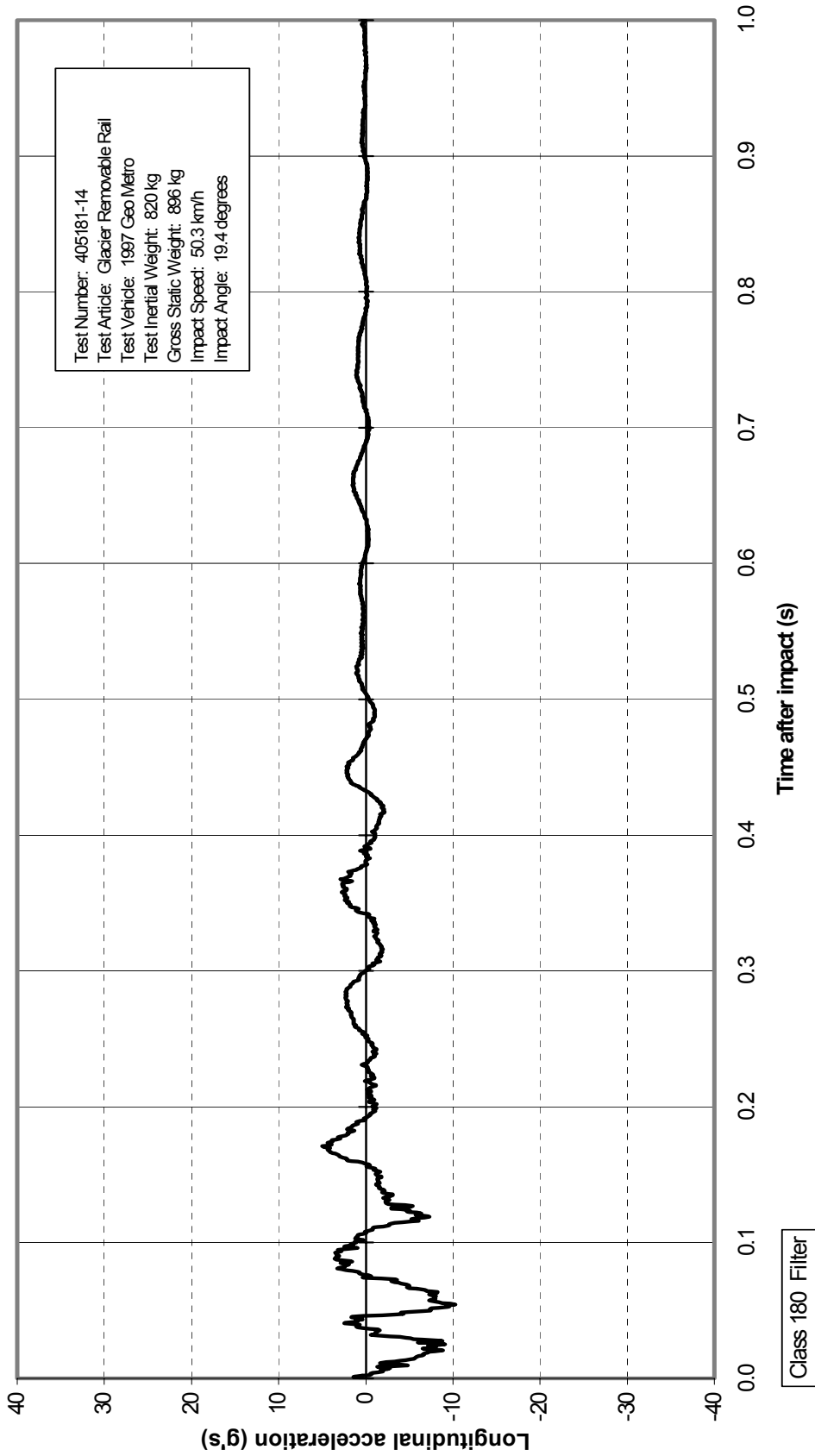

Figure 284. Vehicle longitudinal accelerometer trace for test 405181-14 (accelerometer located on top of engine block).

### Crash Test 405181-14

Accelerometer on bottom of engine block

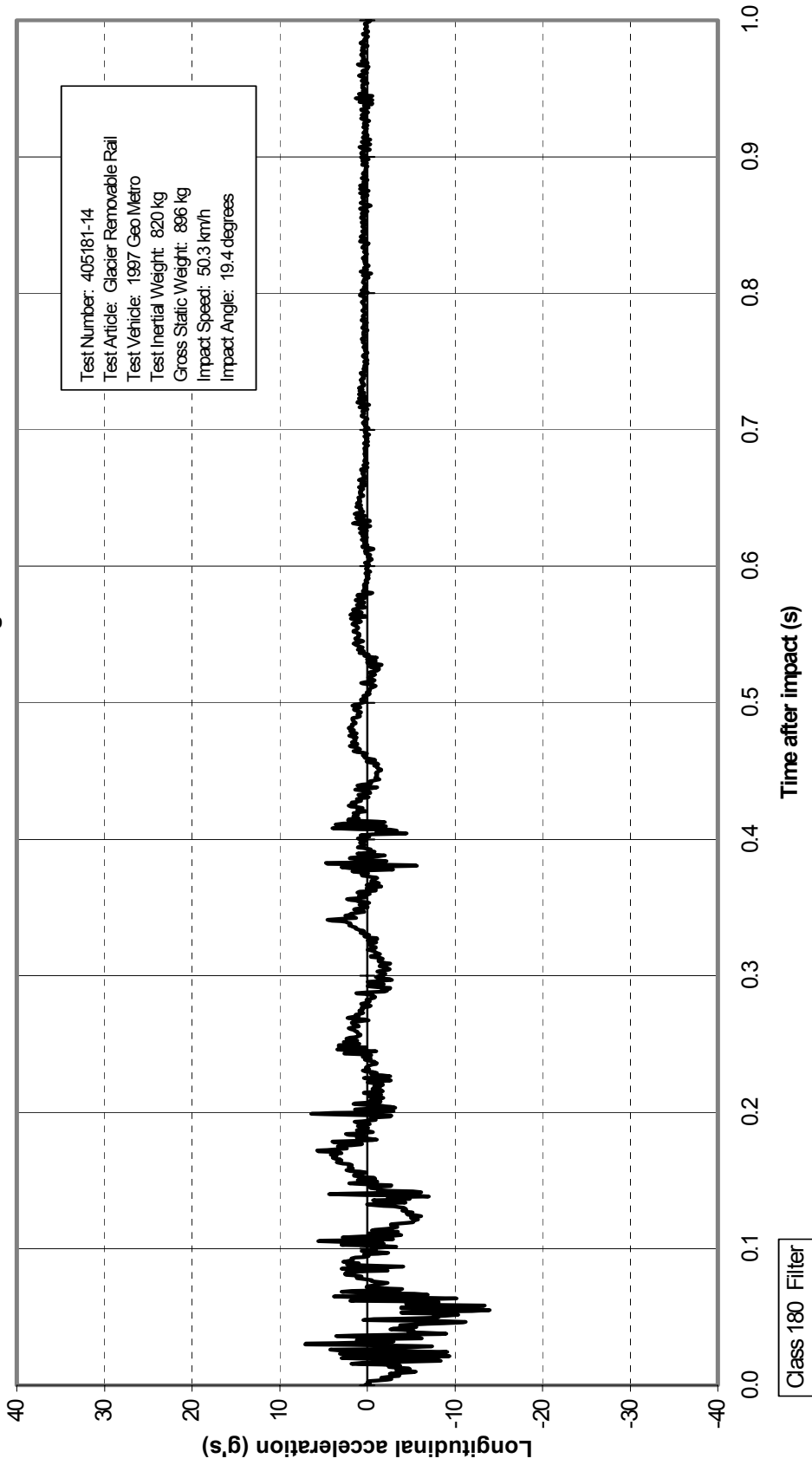

Figure 285. Vehicle longitudinal accelerometer trace for test 405181-14 (accelerometer located on bottom of engine block).

# Roll, Pitch, and Yaw Angles

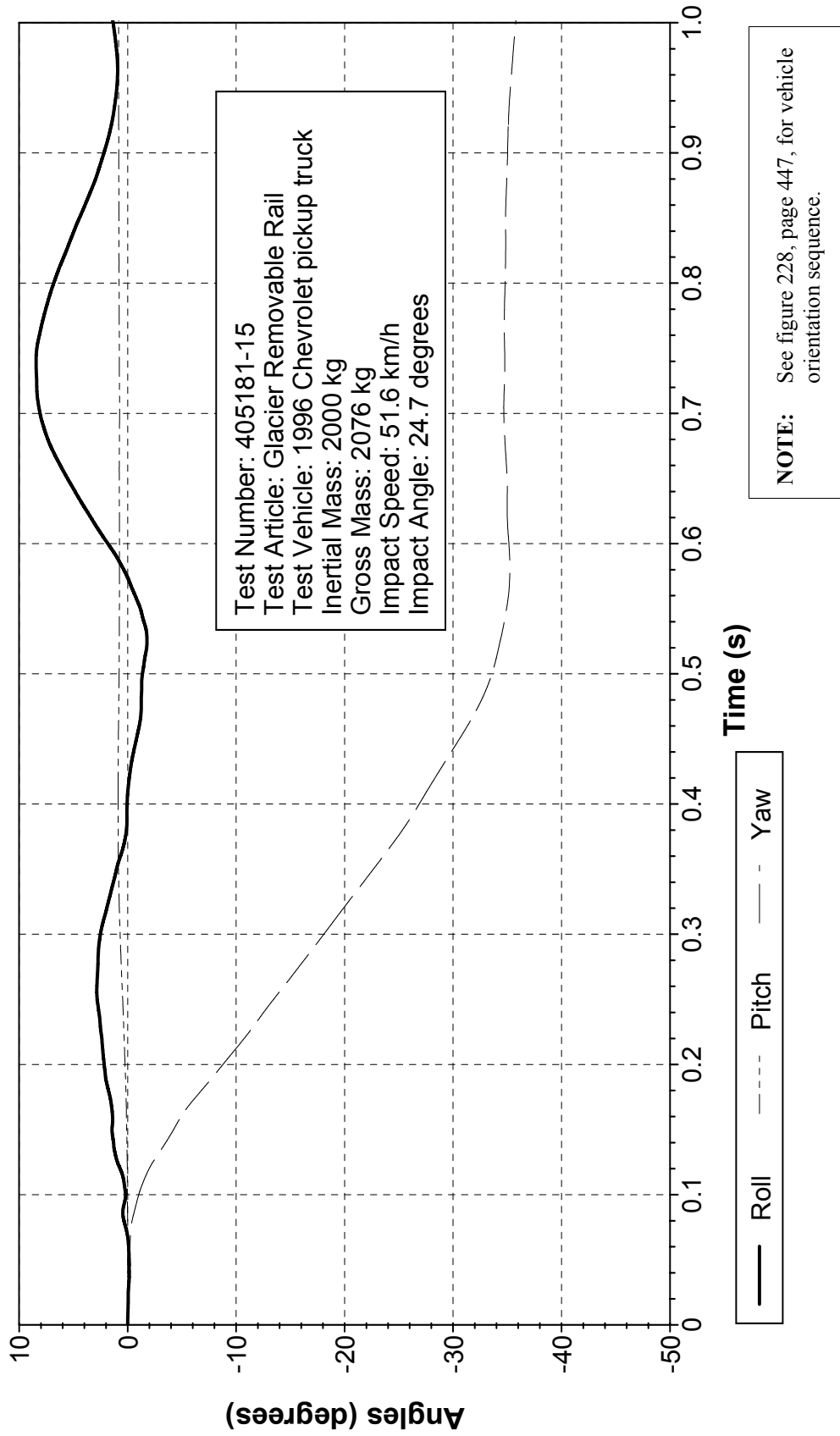

Figure 286. Vehicle angular displacements for test 405181-15.

# X Acceleration at C.G.

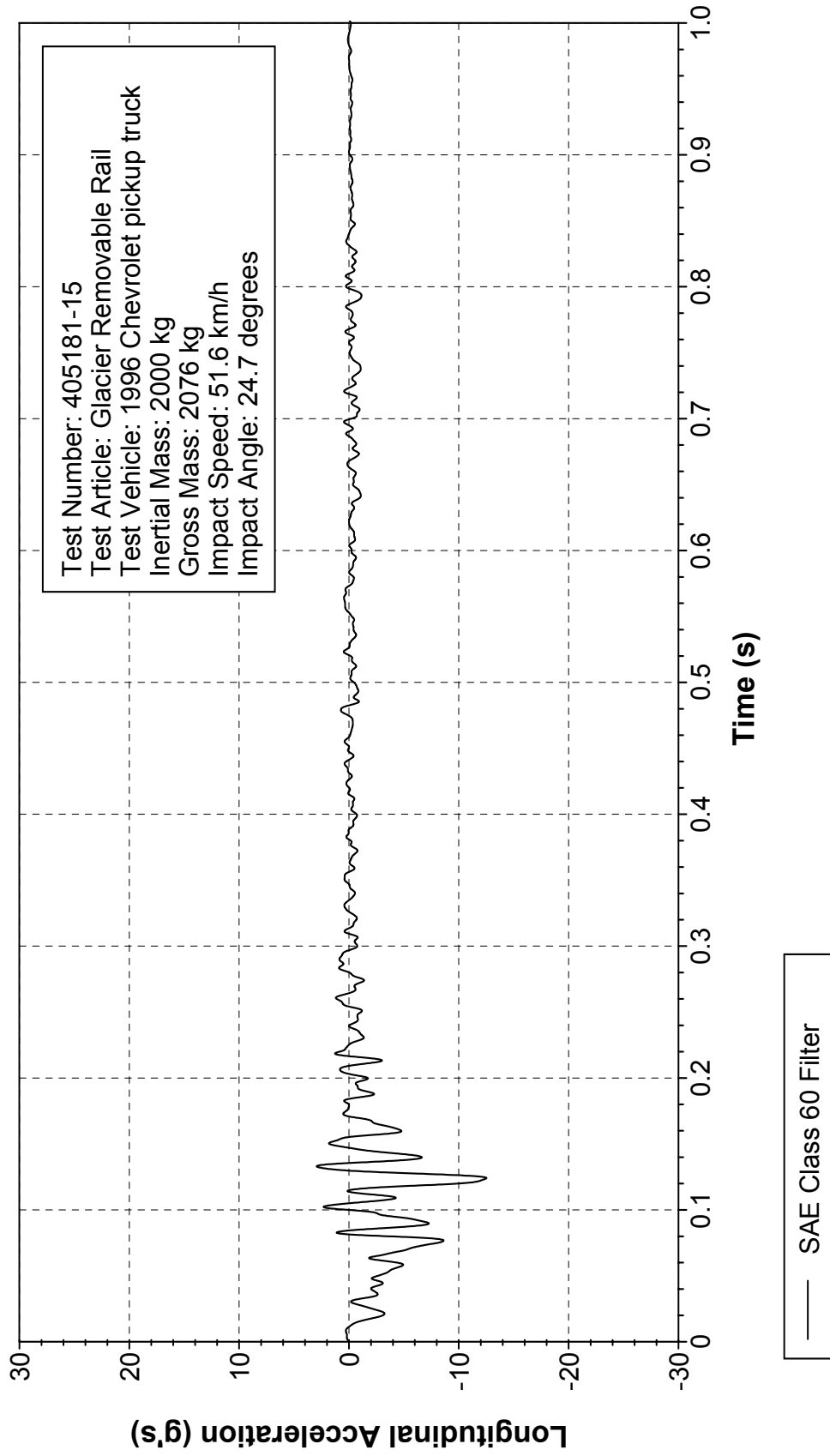

Figure 287. Vehicle longitudinal accelerometer trace for test 405181-15 (accelerometer located at center of gravity).

# Y Acceleration at C.G.

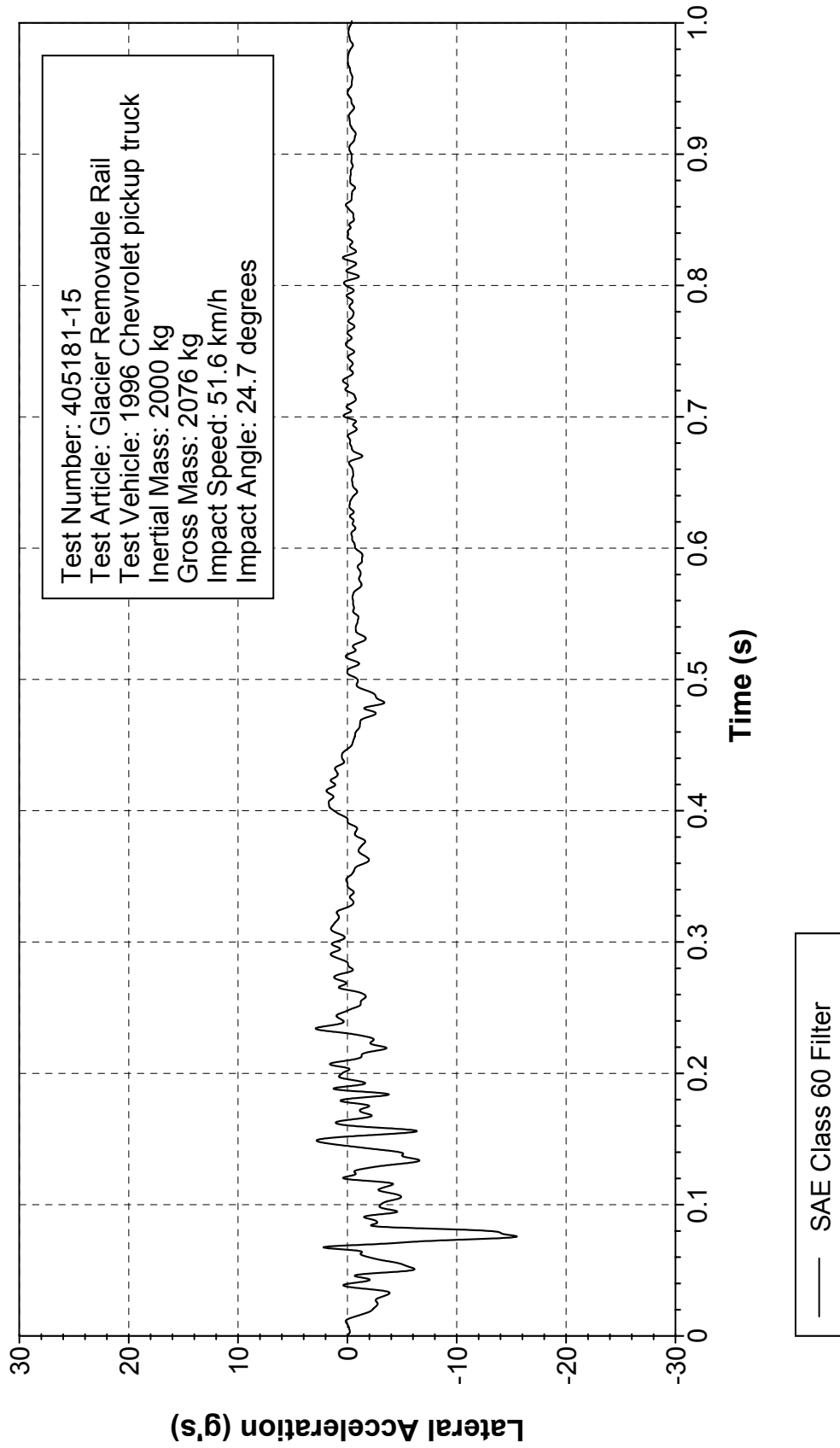

Figure 288. Vehicle lateral accelerometer trace for test 405181-15 (accelerometer located at center of gravity).

# Z Acceleration at C.G.

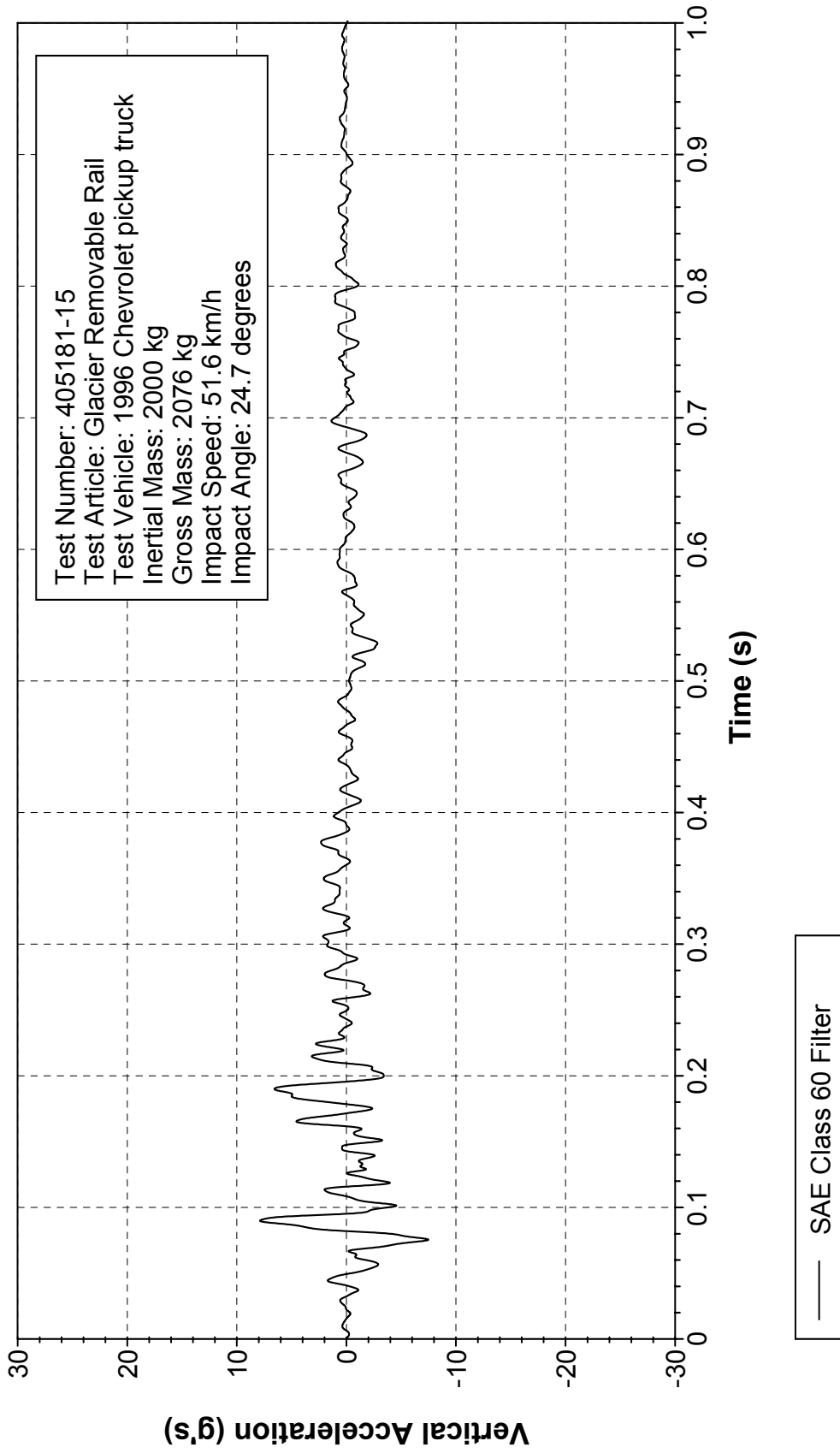

Figure 289. Vehicle vertical accelerometer trace for test 405181-15 (accelerometer located at center of gravity).



# X Acceleration over Rear Axle

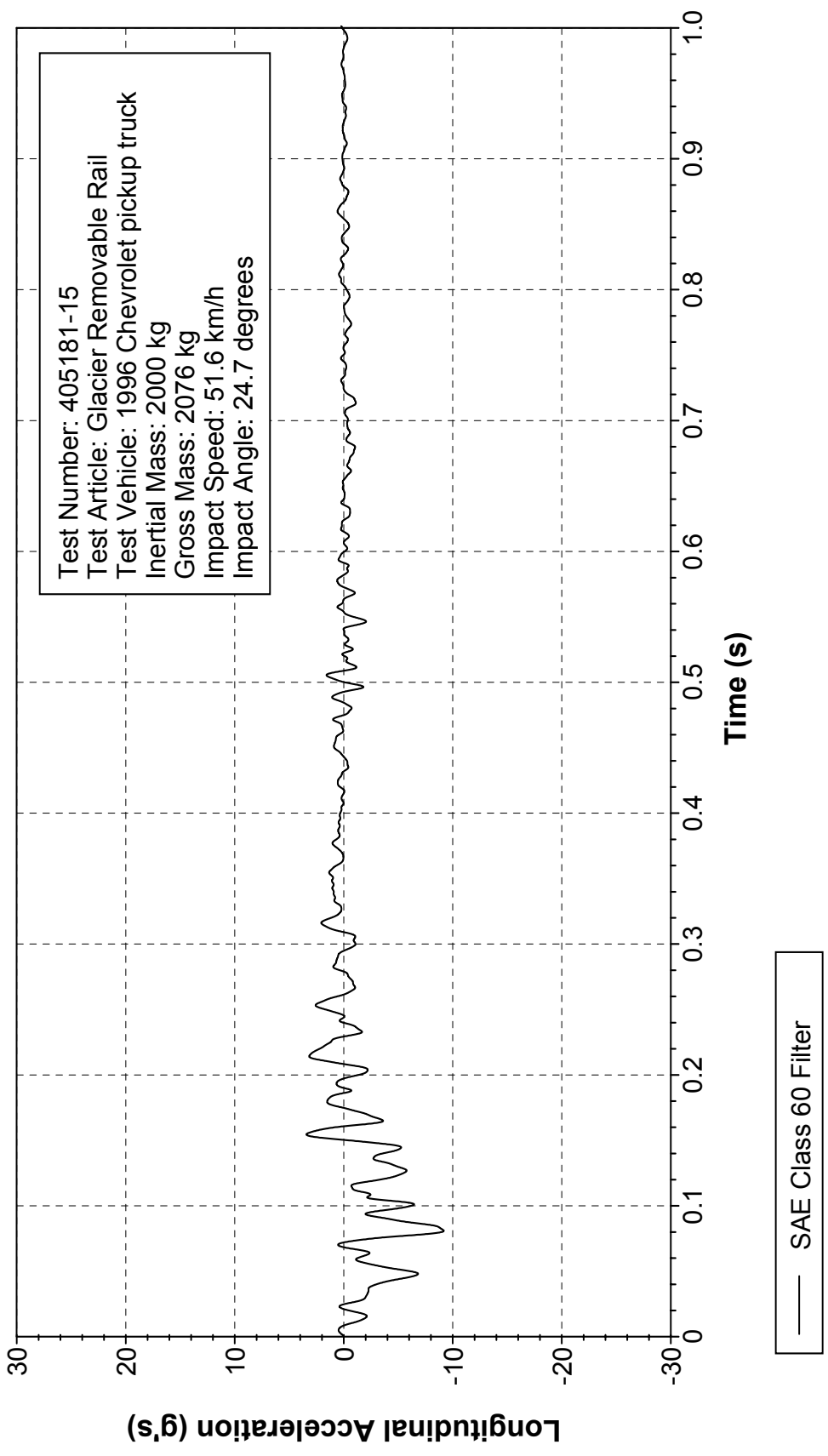

Figure 290. Vehicle longitudinal accelerometer trace for test 405181-15 (accelerometer located over rear axle).

# Y Acceleration over Rear Axle

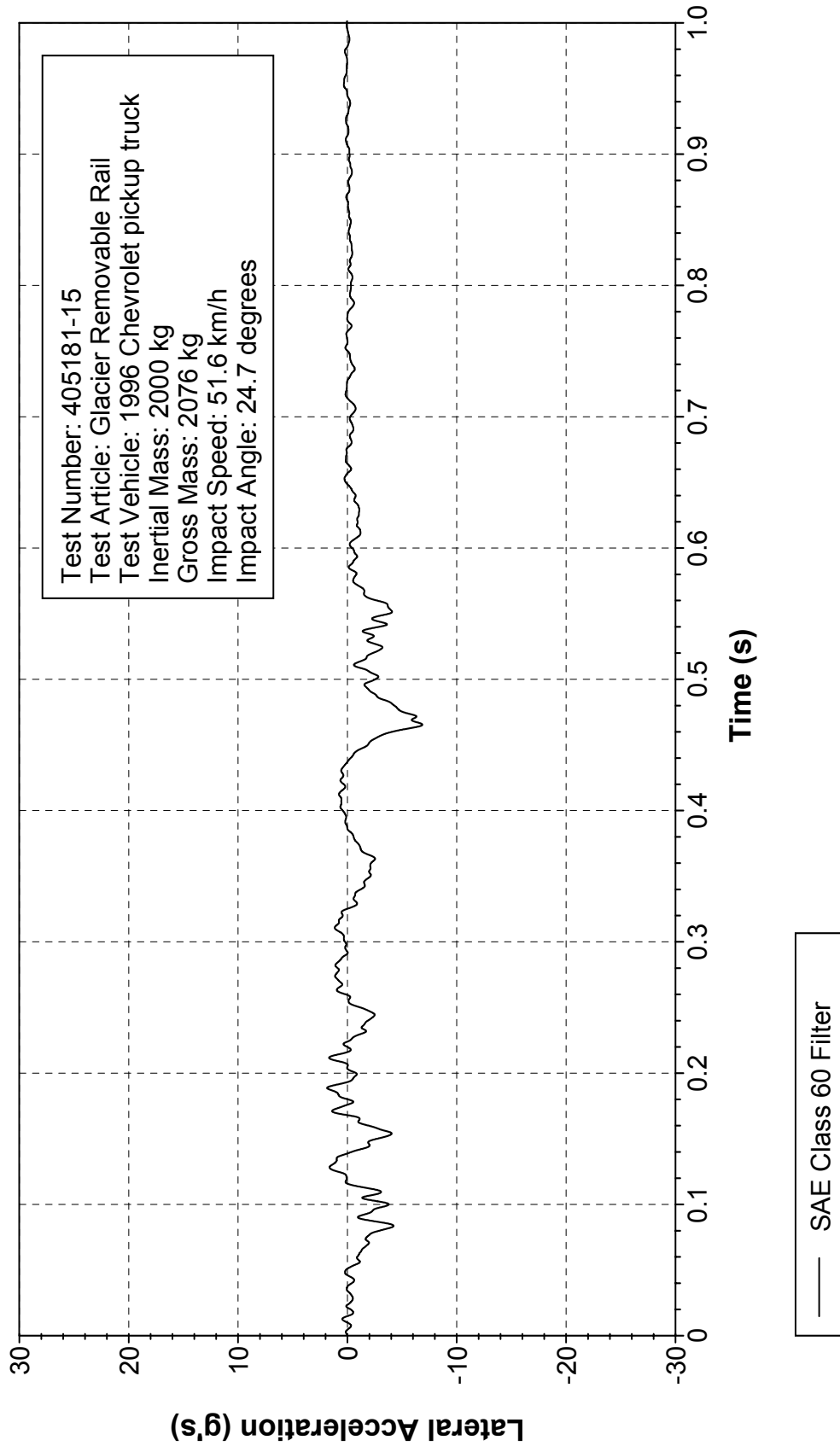

Figure 291. Vehicle lateral accelerometer trace for test 405181-15 (accelerometer located over rear axle).

# Z Acceleration over Rear Axle

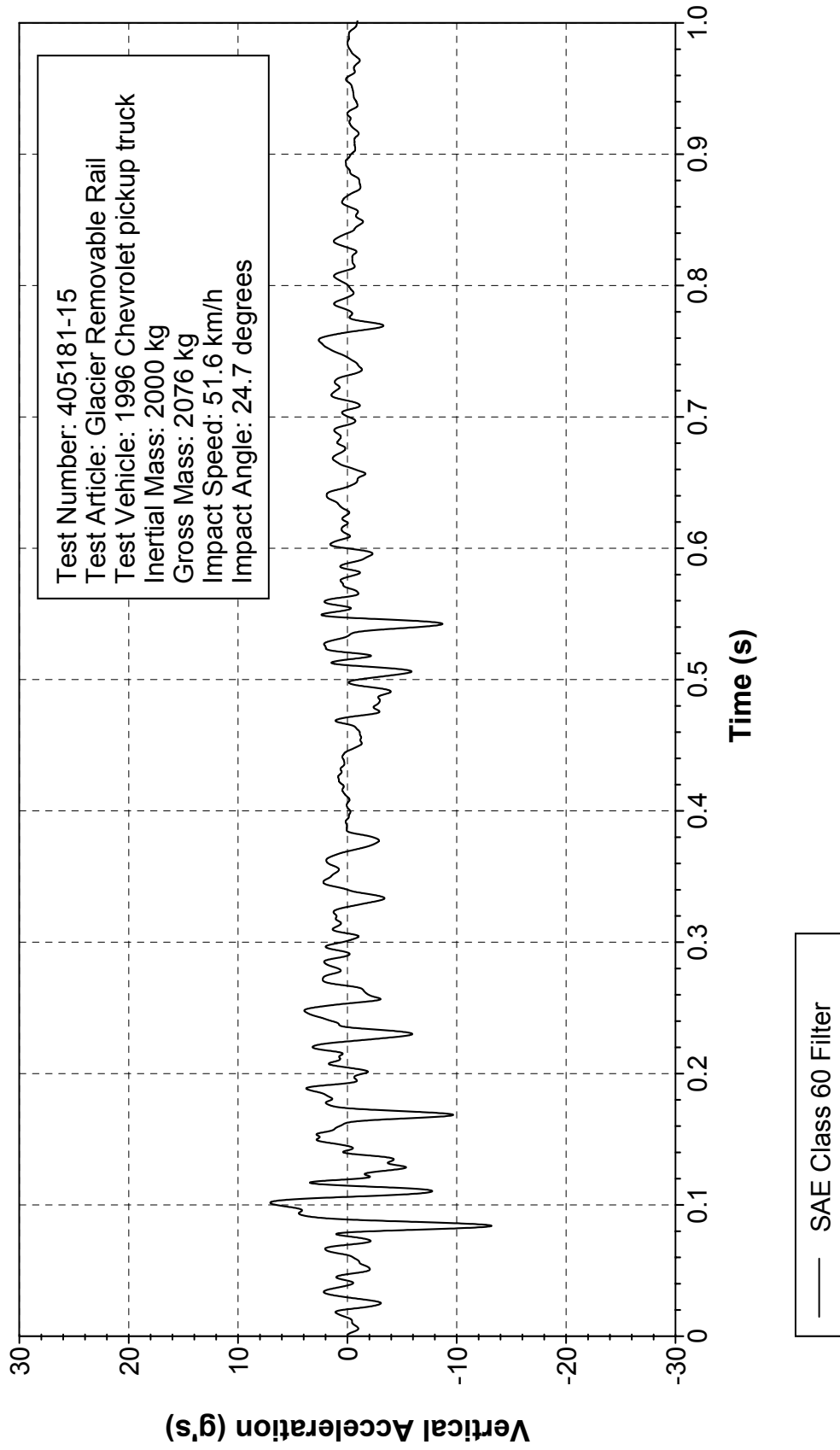

Figure 292. Vehicle vertical accelerometer trace for test 405181-15 (accelerometer located over rear axle).

# Roll, Pitch, and Yaw Angles

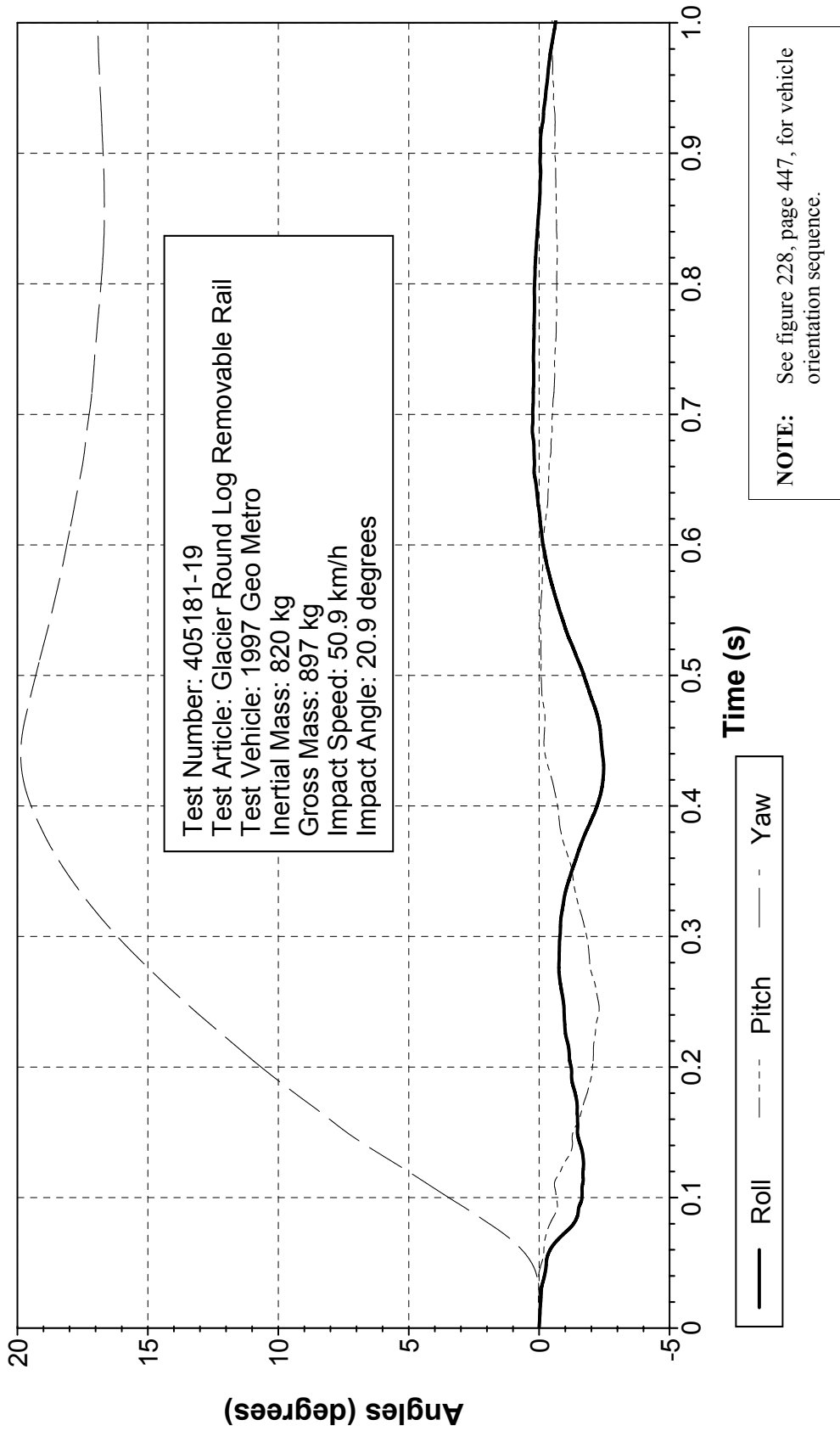

Figure 293. Vehicle angular displacements for test 405181-19.

# X Acceleration at C.G.

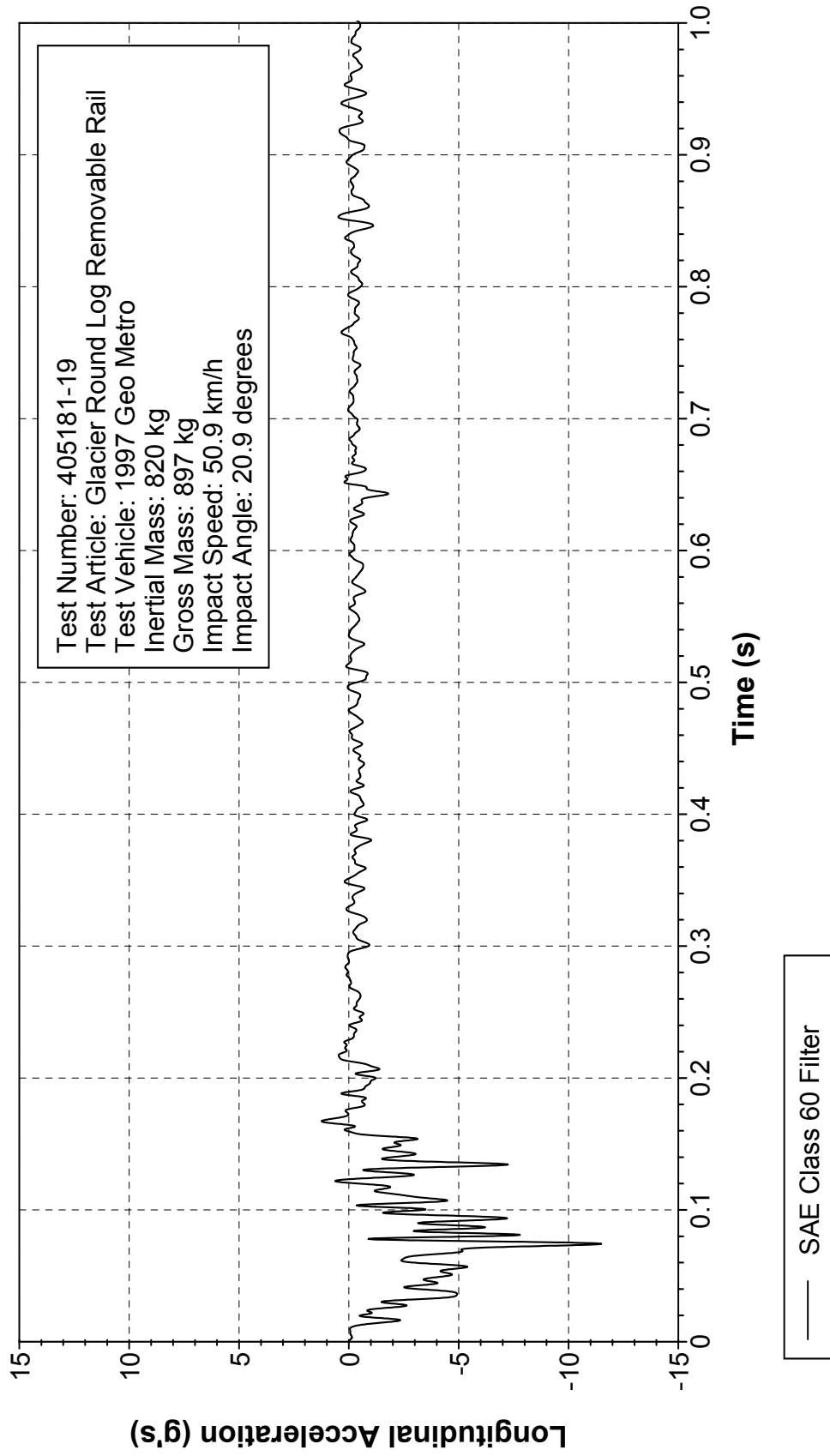

Figure 294. Vehicle longitudinal accelerometer trace for test 405181-19 (accelerometer located at center of gravity).

# Y Acceleration at C.G.

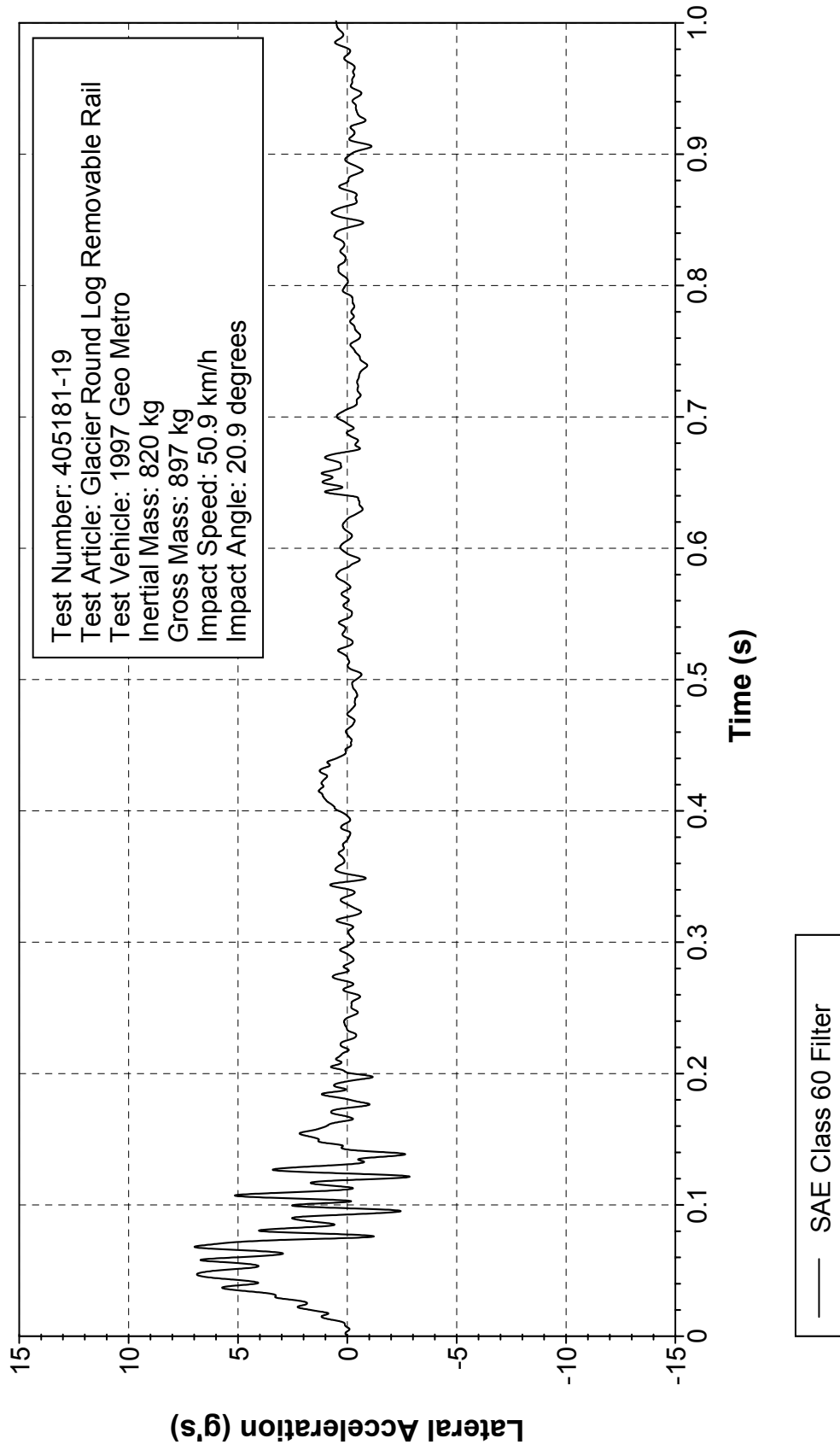

Figure 295. Vehicle lateral accelerometer trace for test 405181-19 (accelerometer located at center of gravity).

## Z Acceleration at C.G.

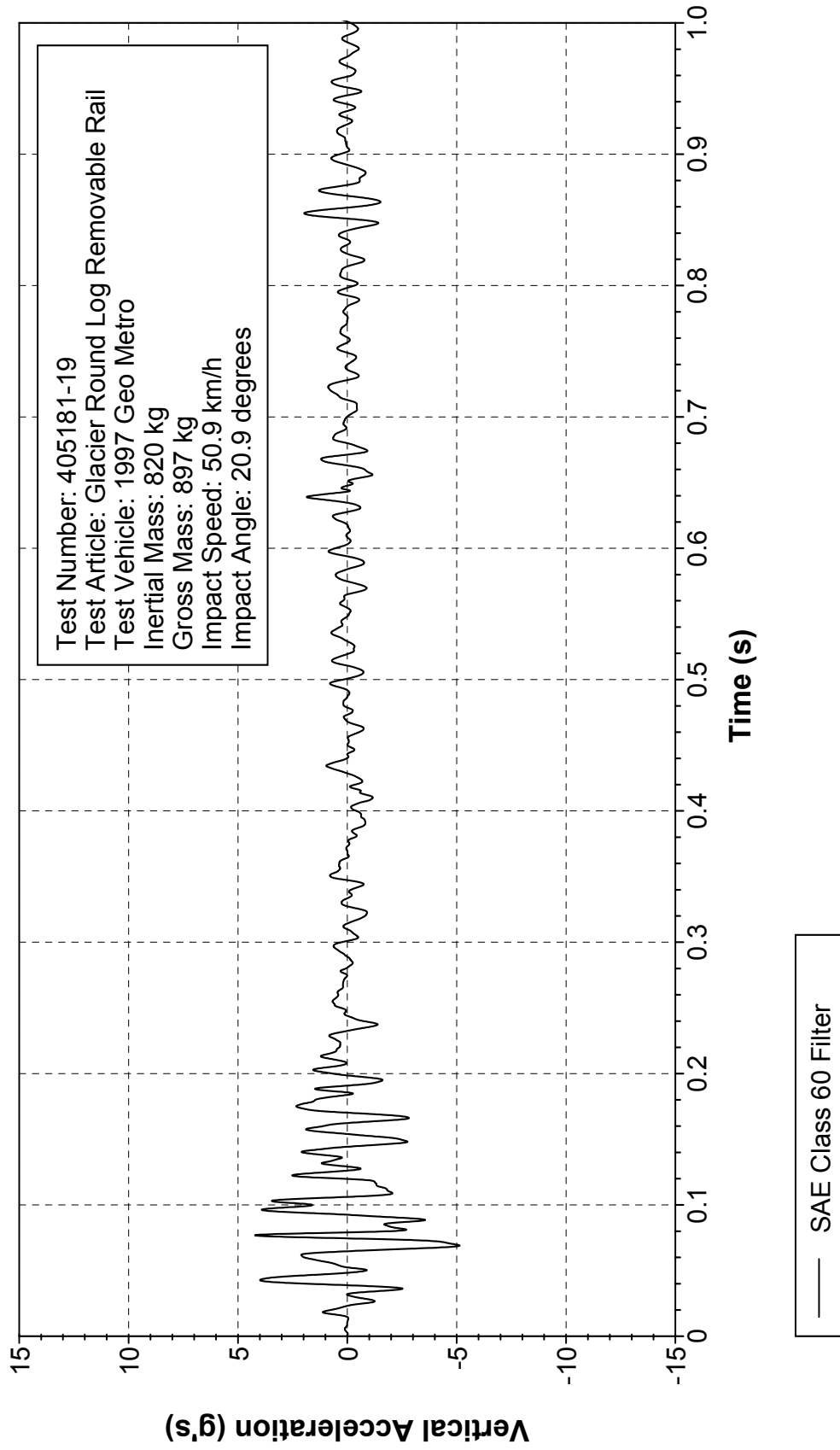

Figure 296. Vehicle vertical accelerometer trace for test 405181-19 (accelerometer located at center of gravity).

# X Acceleration over Rear Axle

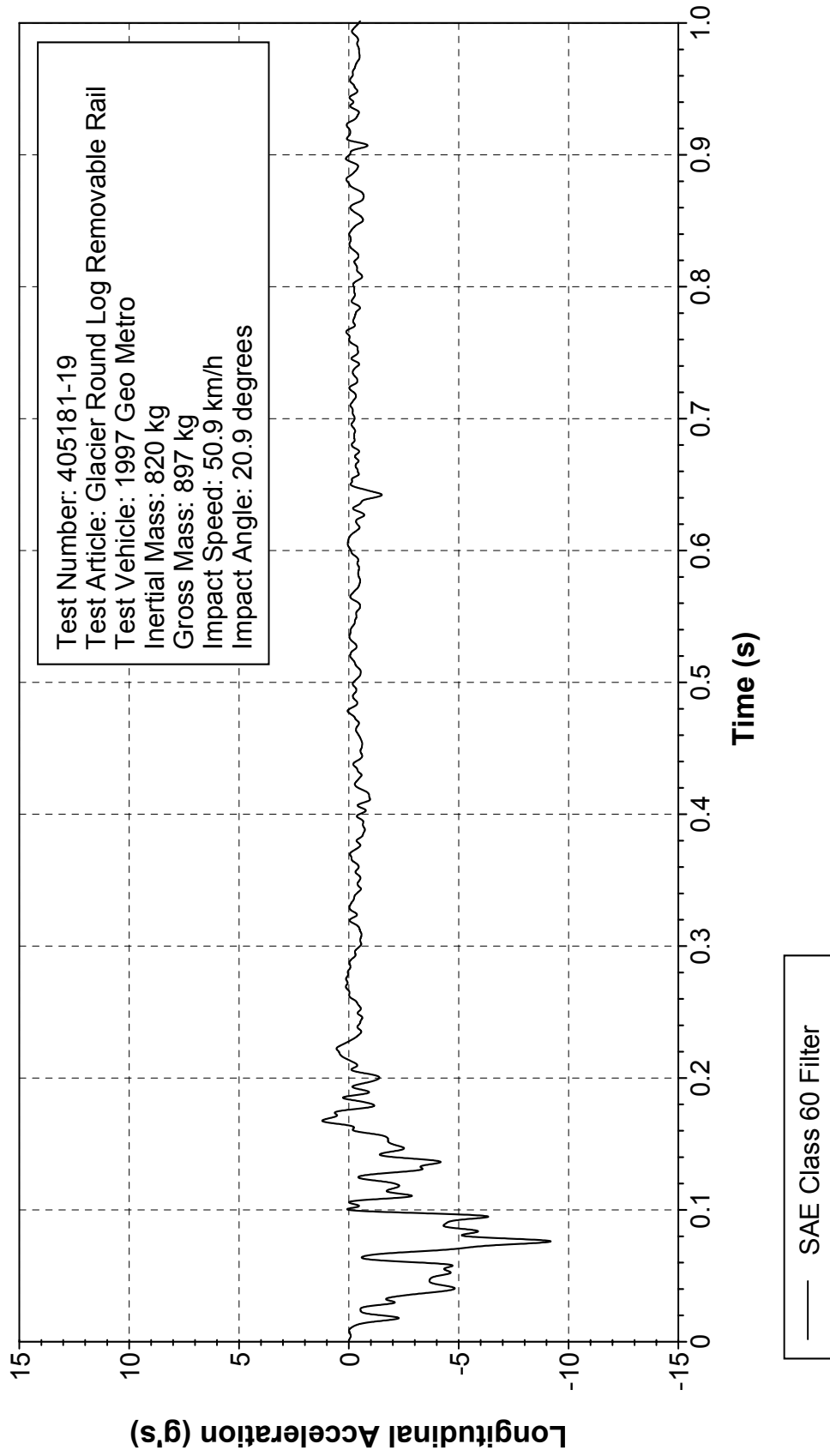

Figure 297. Vehicle longitudinal accelerometer trace for test 405181-19 (accelerometer located over rear axle).



# Y Acceleration over Rear Axle

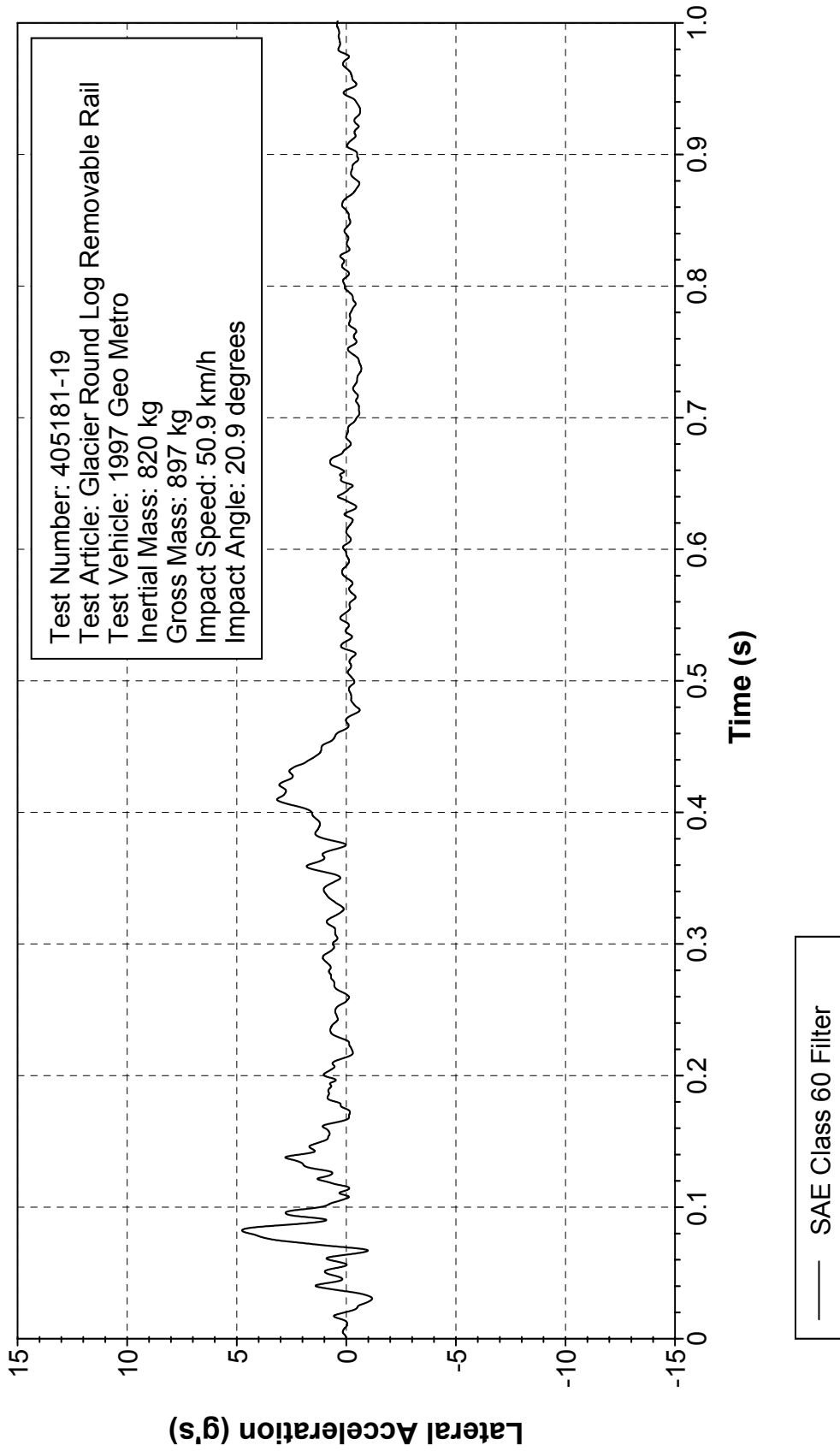

Figure 298. Vehicle lateral accelerometer trace for test 405181-19 (accelerometer located over rear axle).

# Z Acceleration over Rear Axle

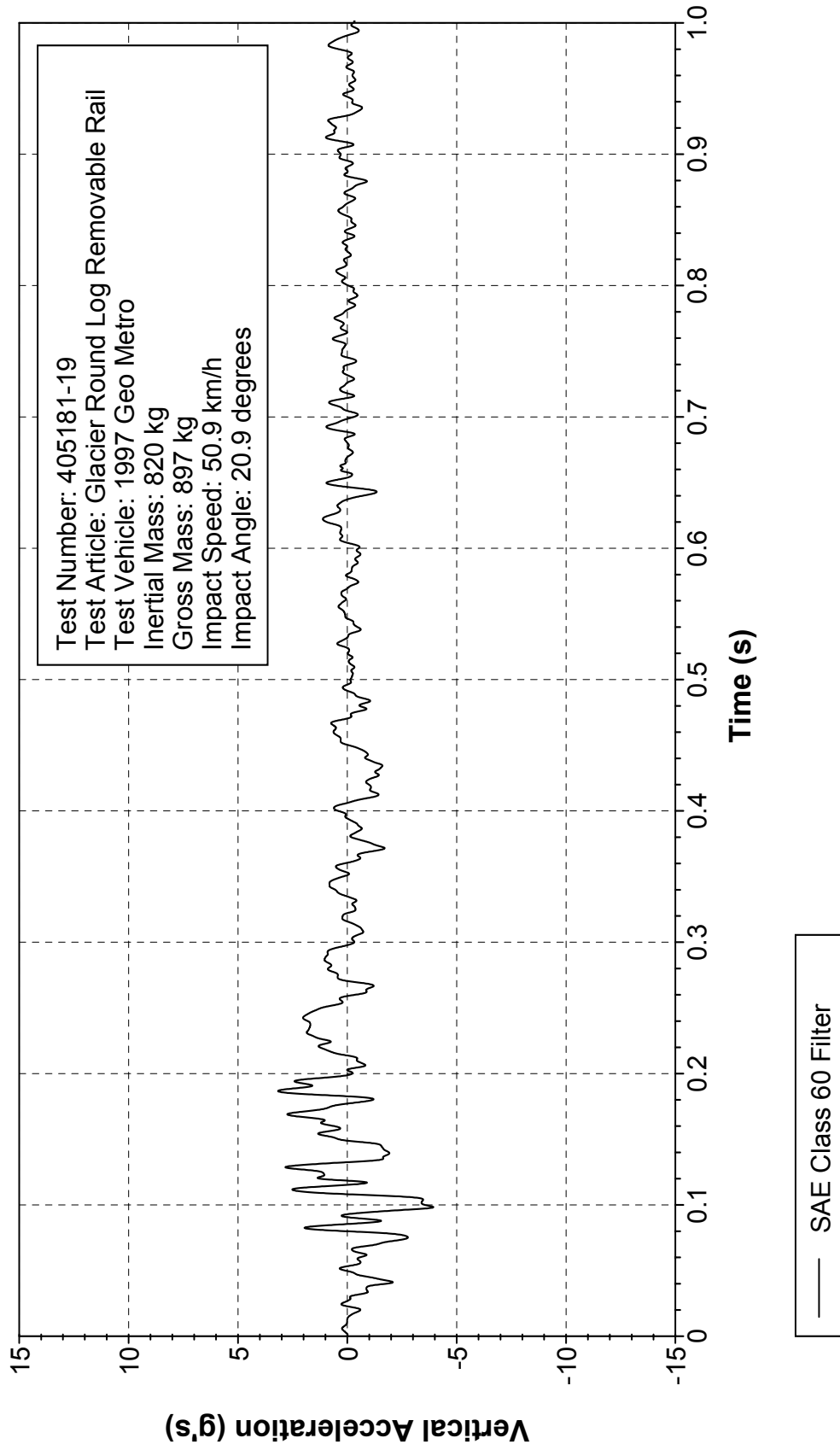

Figure 299. Vehicle vertical accelerometer trace for test 405181-19 (accelerometer located over rear axle).

# Roll, Pitch, and Yaw Angles

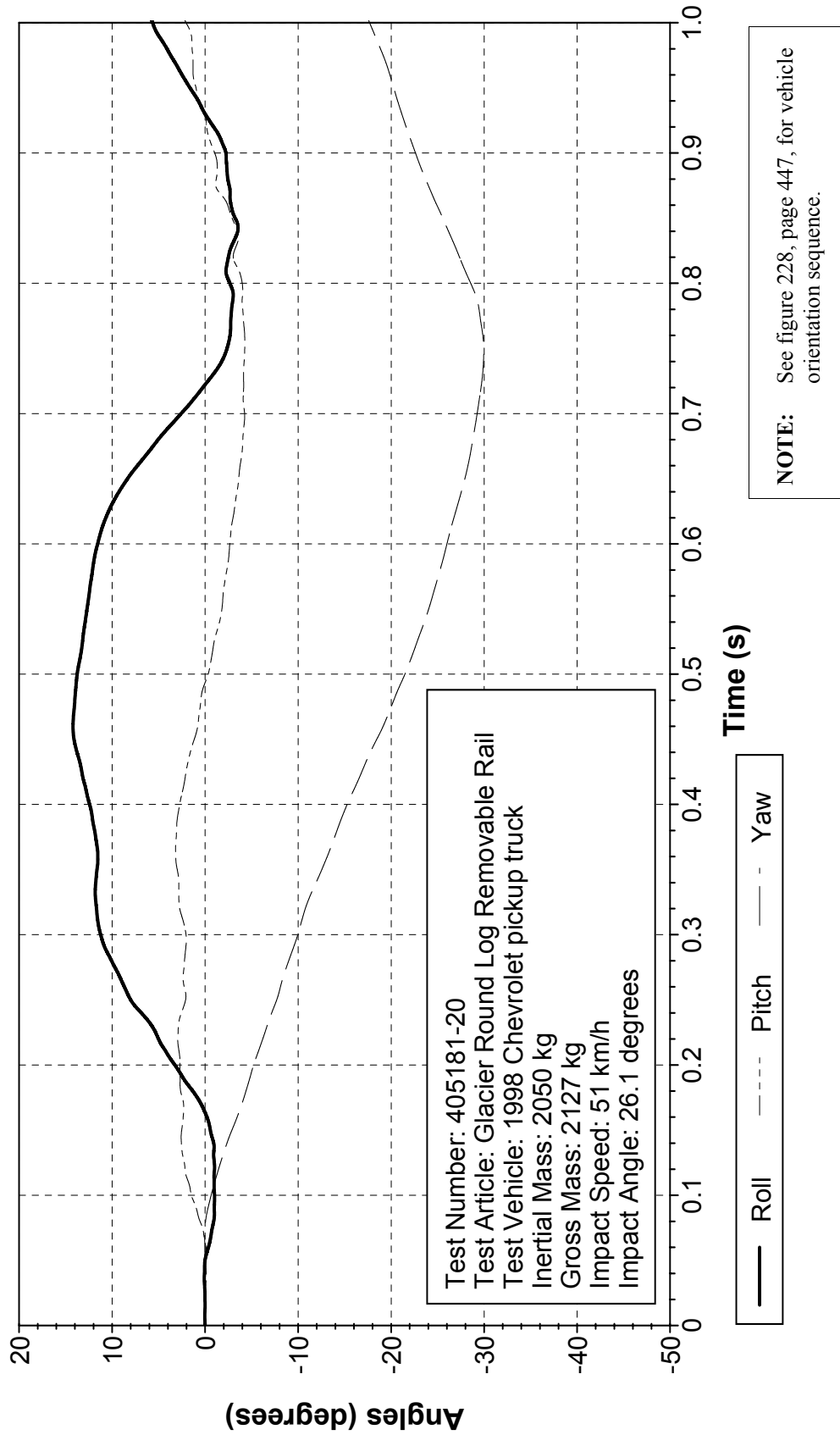

Figure 300. Vehicle angular displacements for test 405181-20.

# X Acceleration at C.G.

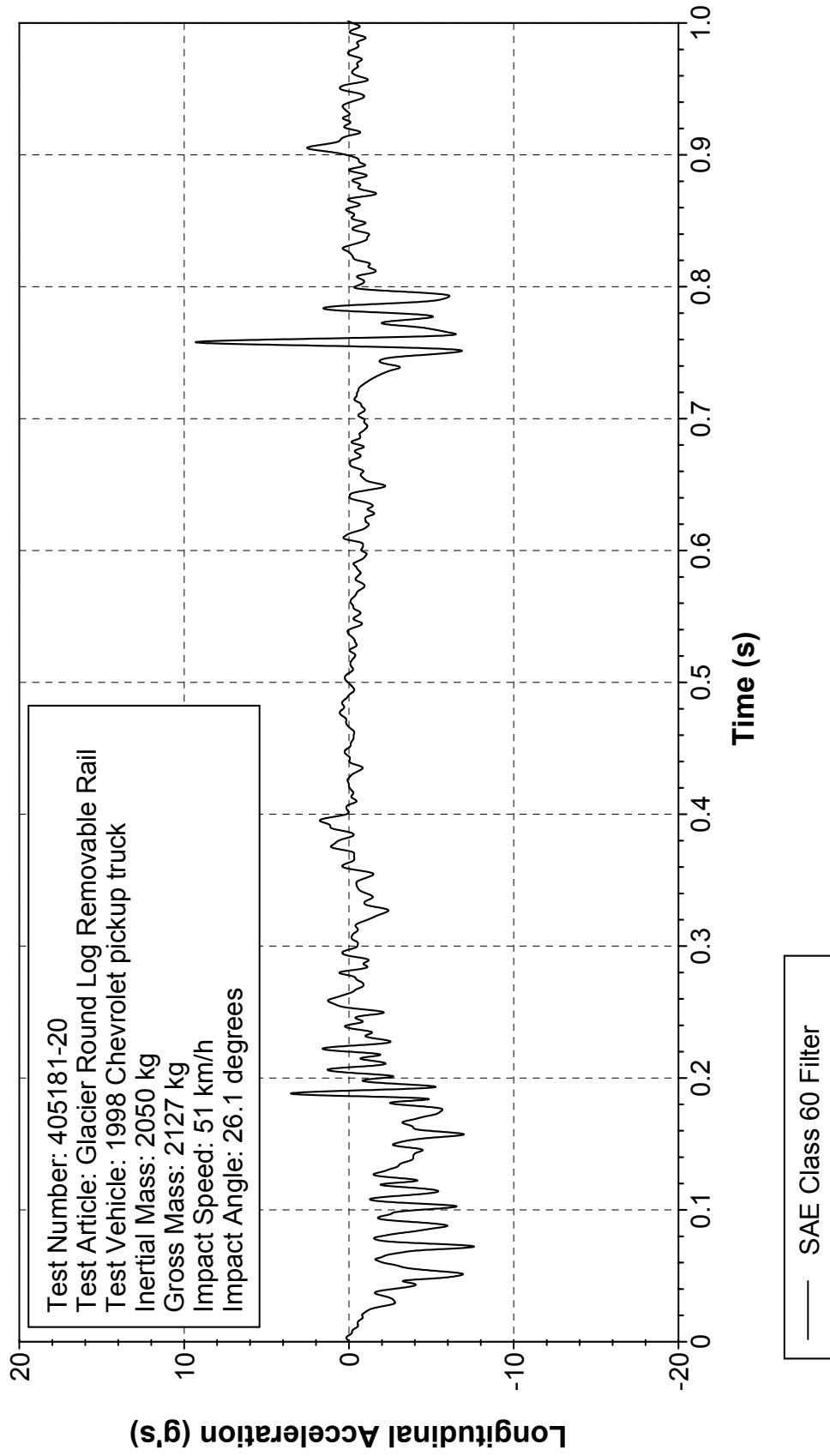

Figure 301. Vehicle longitudinal accelerometer trace for test 405181-20 (accelerometer located at center of gravity).

# Y Acceleration at C.G.

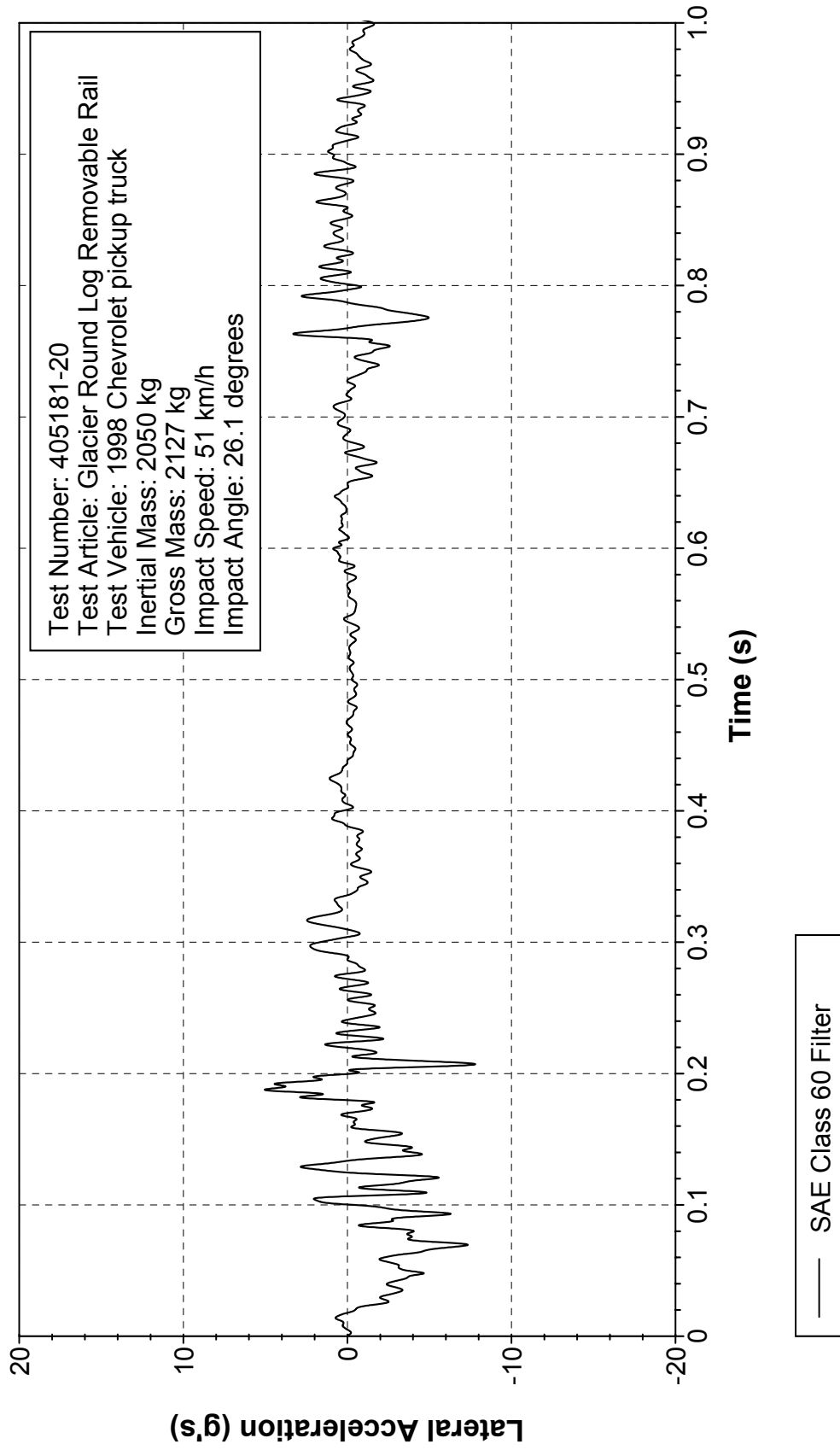

Figure 302. Vehicle lateral accelerometer trace for test 405181-20 (accelerometer located at center of gravity).

# Z Acceleration at C.G.

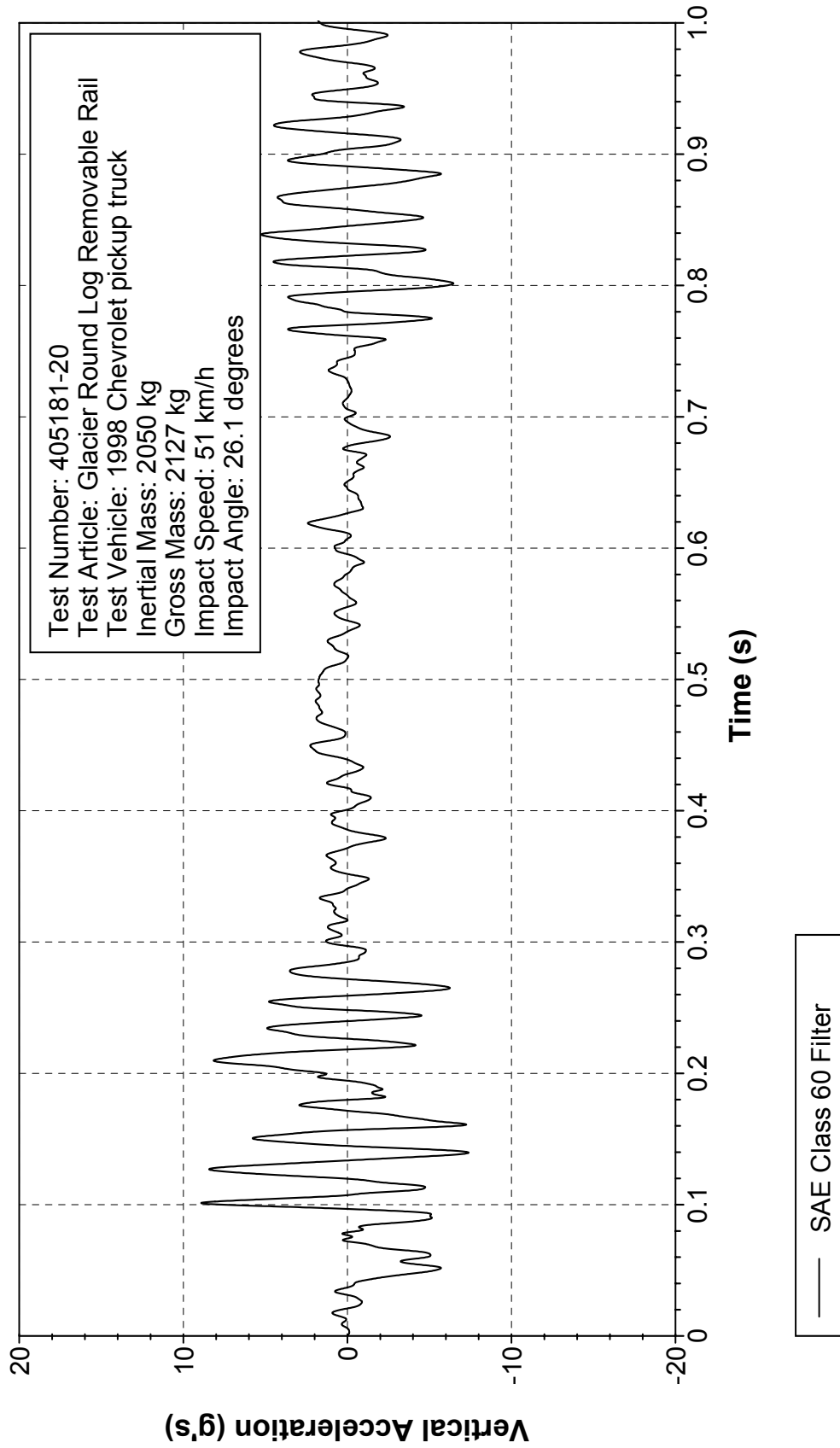

Figure 303. Vehicle vertical accelerometer trace for test 405181-20 (accelerometer located at center of gravity).

# X Acceleration over Rear Axle

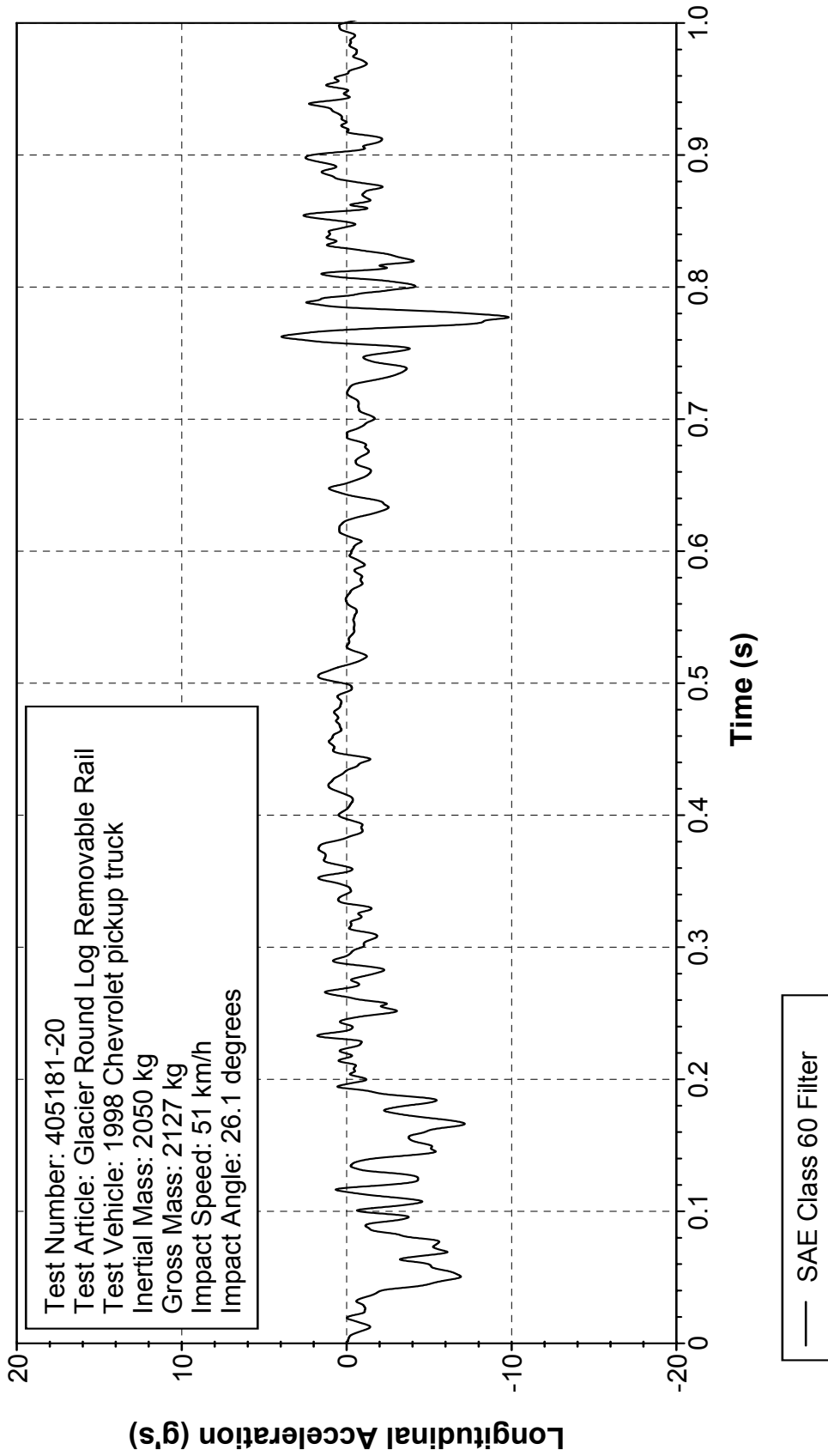

Figure 304. Vehicle longitudinal accelerometer trace for test 405181-20 (accelerometer located over rear axle).

# Y Acceleration over Rear Axle

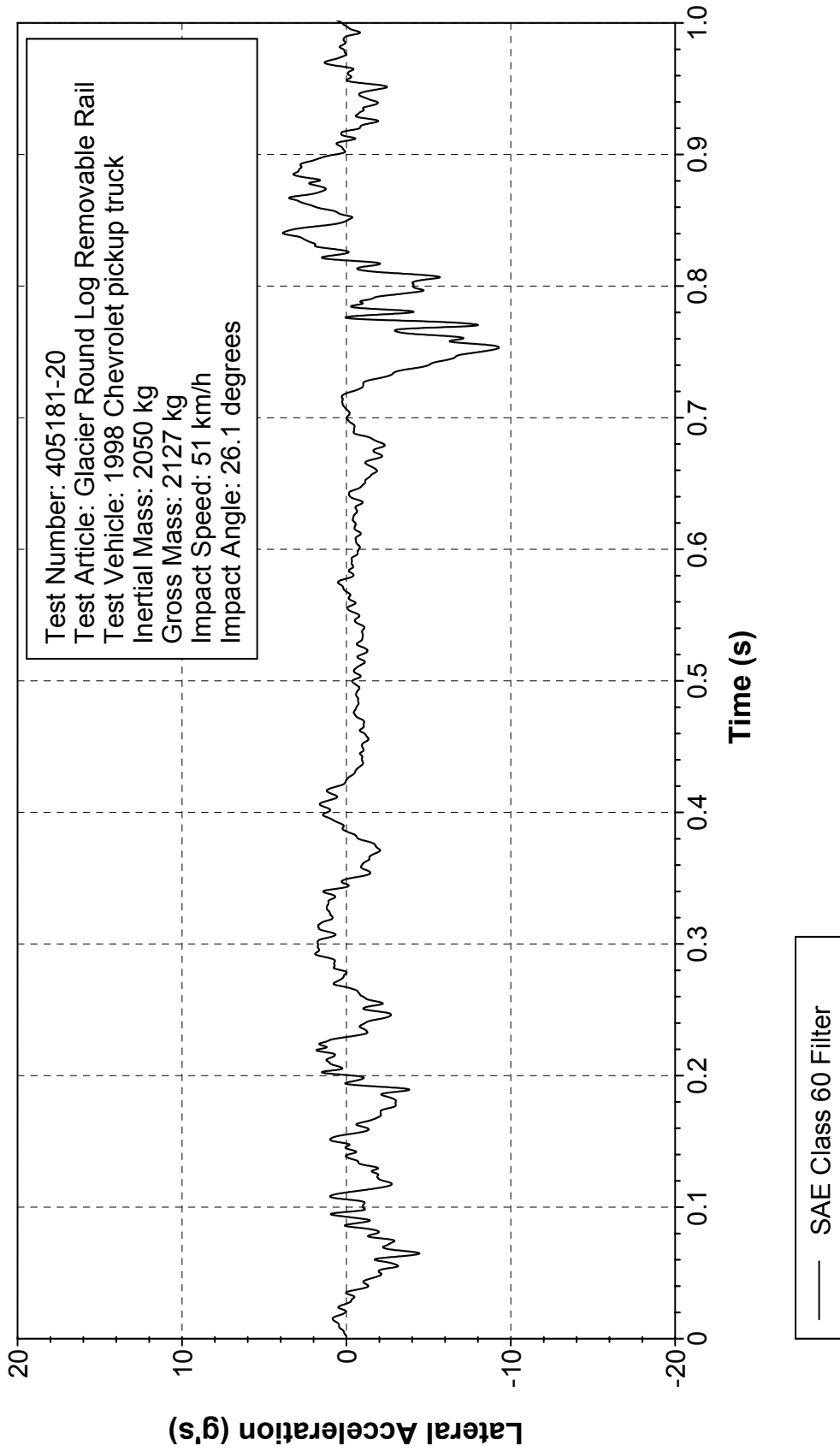

Figure 305. Vehicle lateral accelerometer trace for test 405181-20 (accelerometer located over rear axle).



# Z Acceleration over Rear Axle

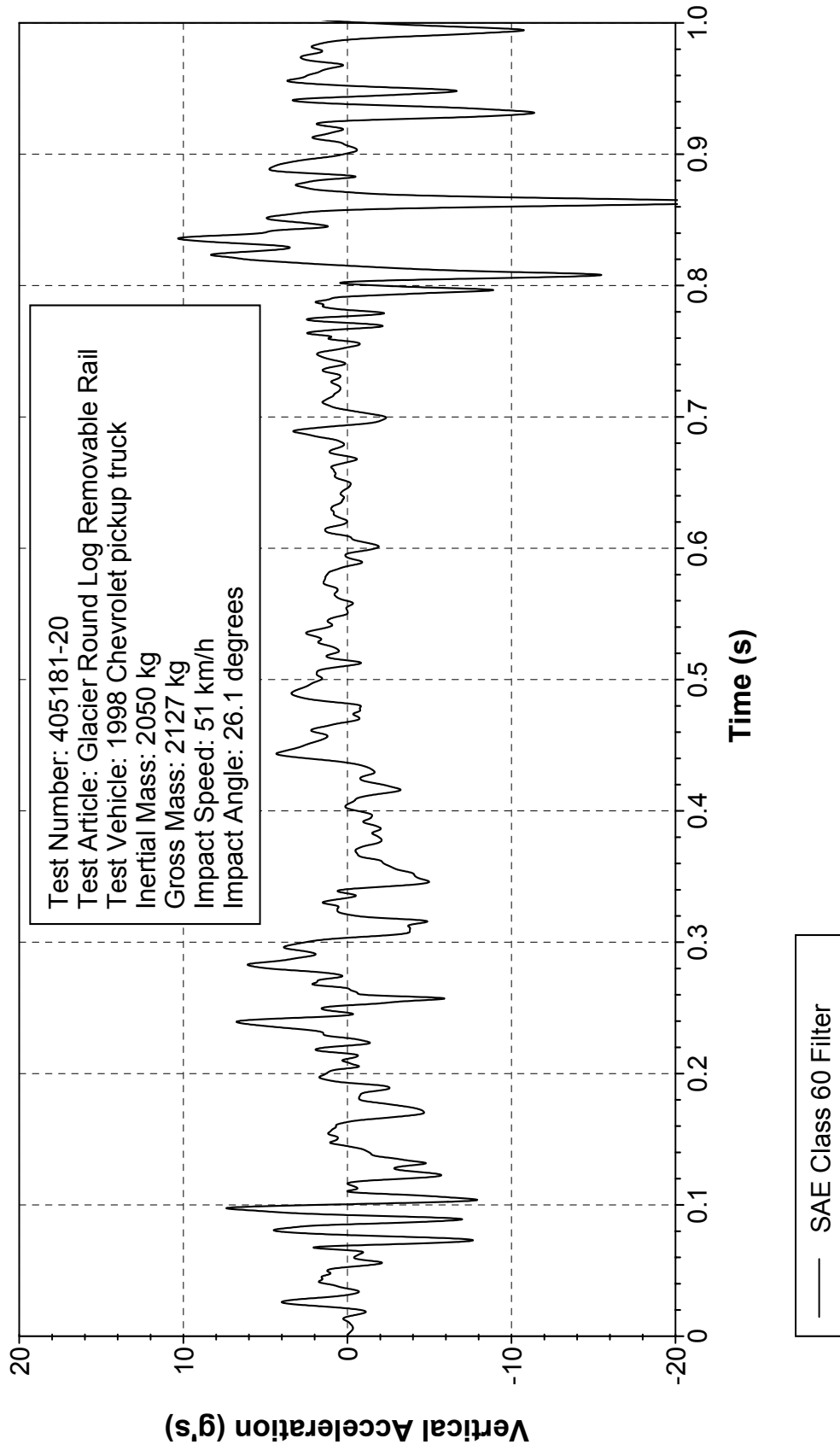

Figure 306. Vehicle vertical accelerometer trace for test 405181-20 (accelerometer located over rear axle).

# Roll, Pitch, and Yaw Angles

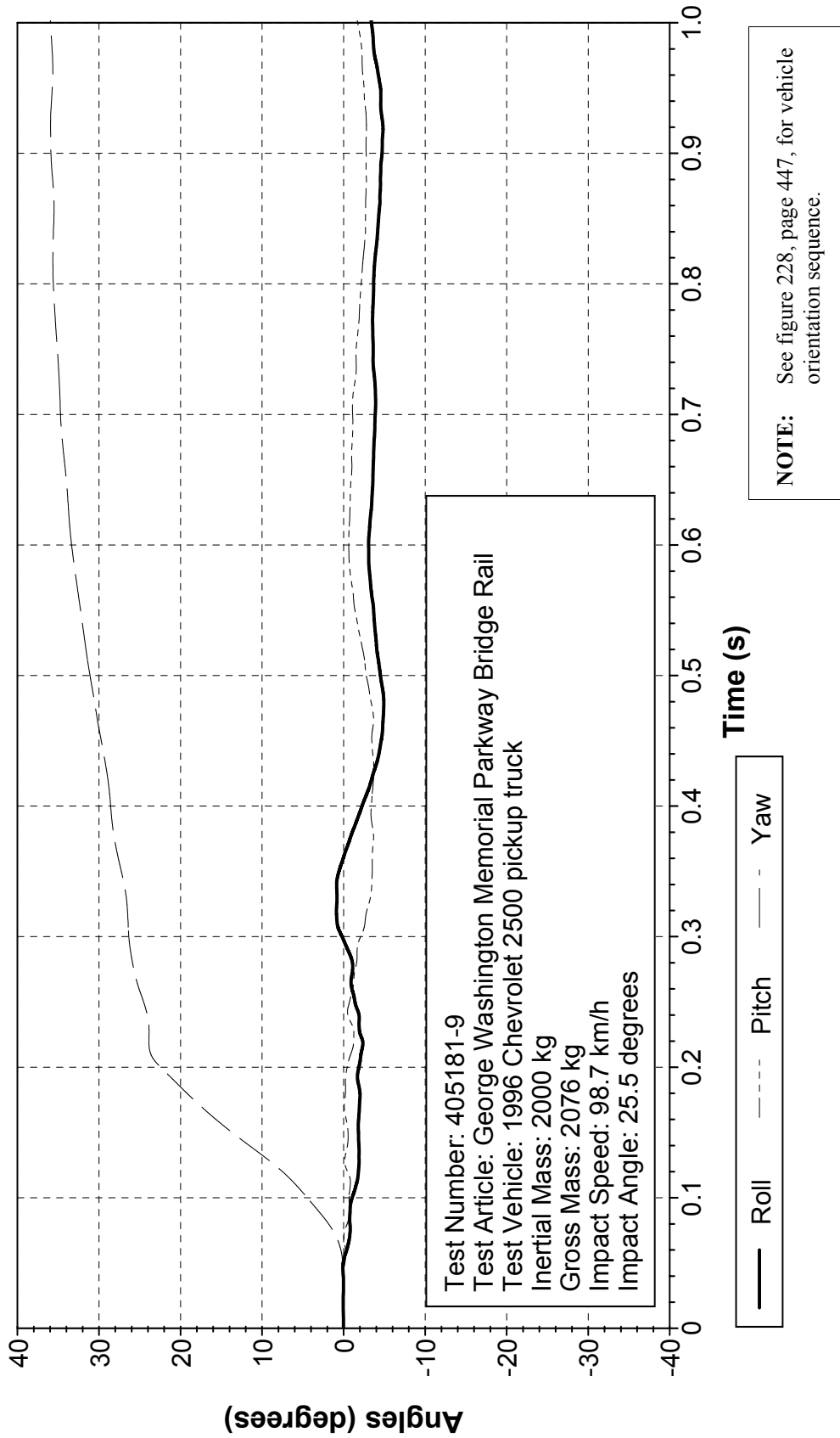

Figure 307. Vehicle angular displacements for test 405181-9.

# X Acceleration at C.G.

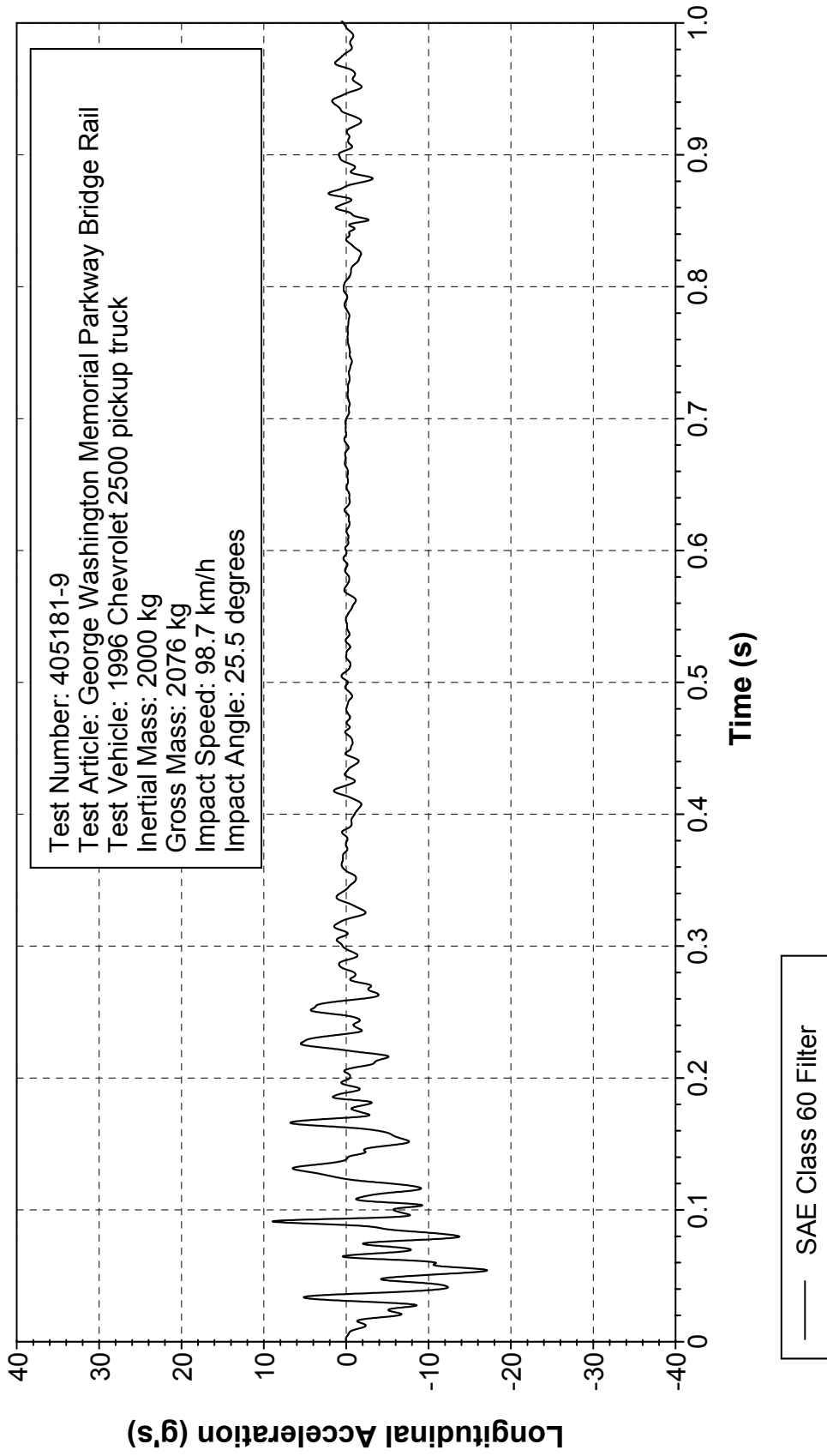

Figure 308. Vehicle longitudinal accelerometer trace for test 405181-9 (accelerometer located at center of gravity).

# Y Acceleration at C.G.

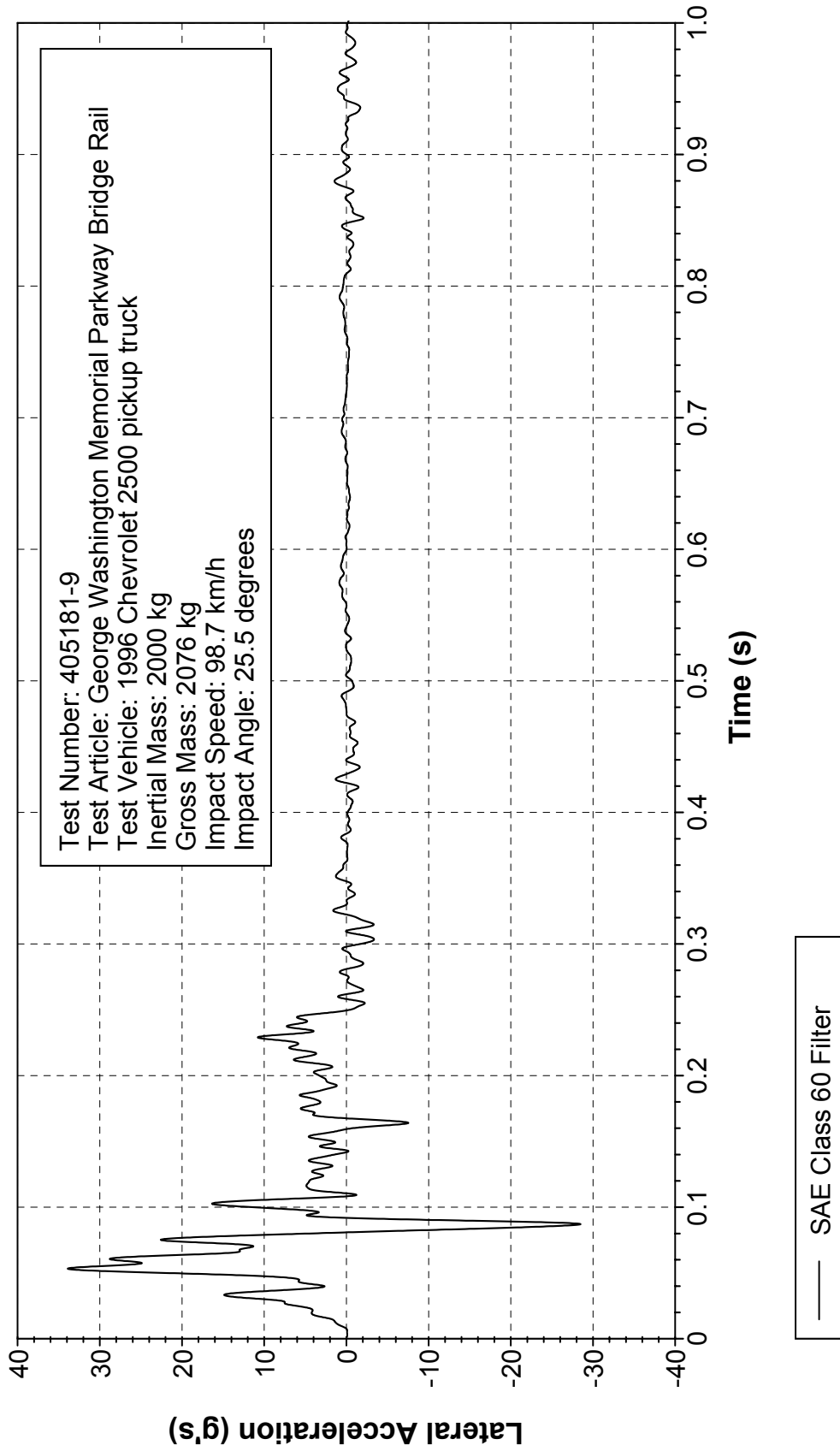

Figure 309. Vehicle lateral accelerometer trace for test 405181-9 (accelerometer located at center of gravity).

## Z Acceleration at C.G.

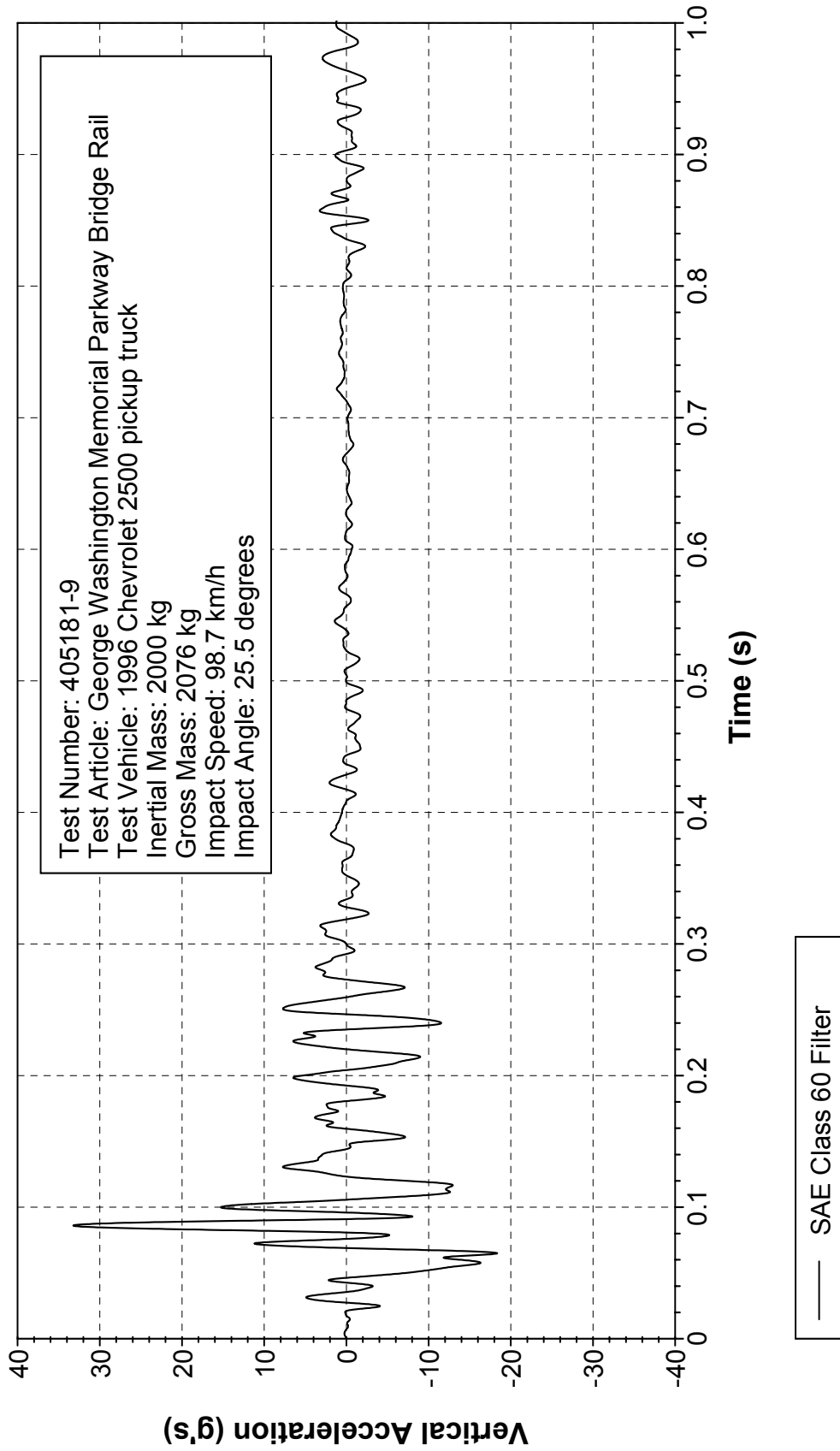

Figure 310. Vehicle vertical accelerometer trace for test 405181-9 (accelerometer located at center of gravity).

# X Acceleration over Rear Axle

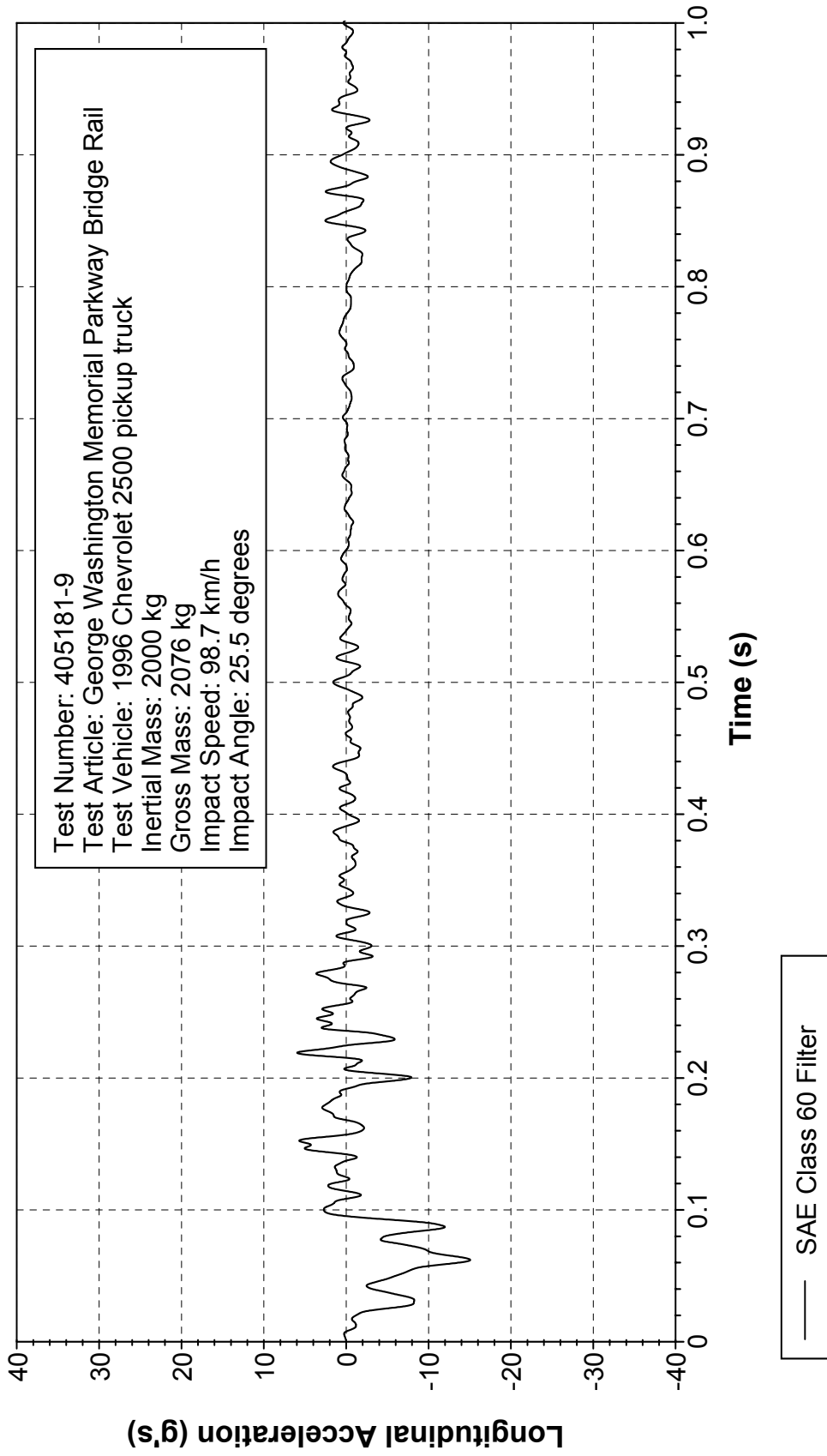

Figure 311. Vehicle longitudinal accelerometer trace for test 405181-9 (accelerometer located over rear axle).

# Y Acceleration over Rear Axle

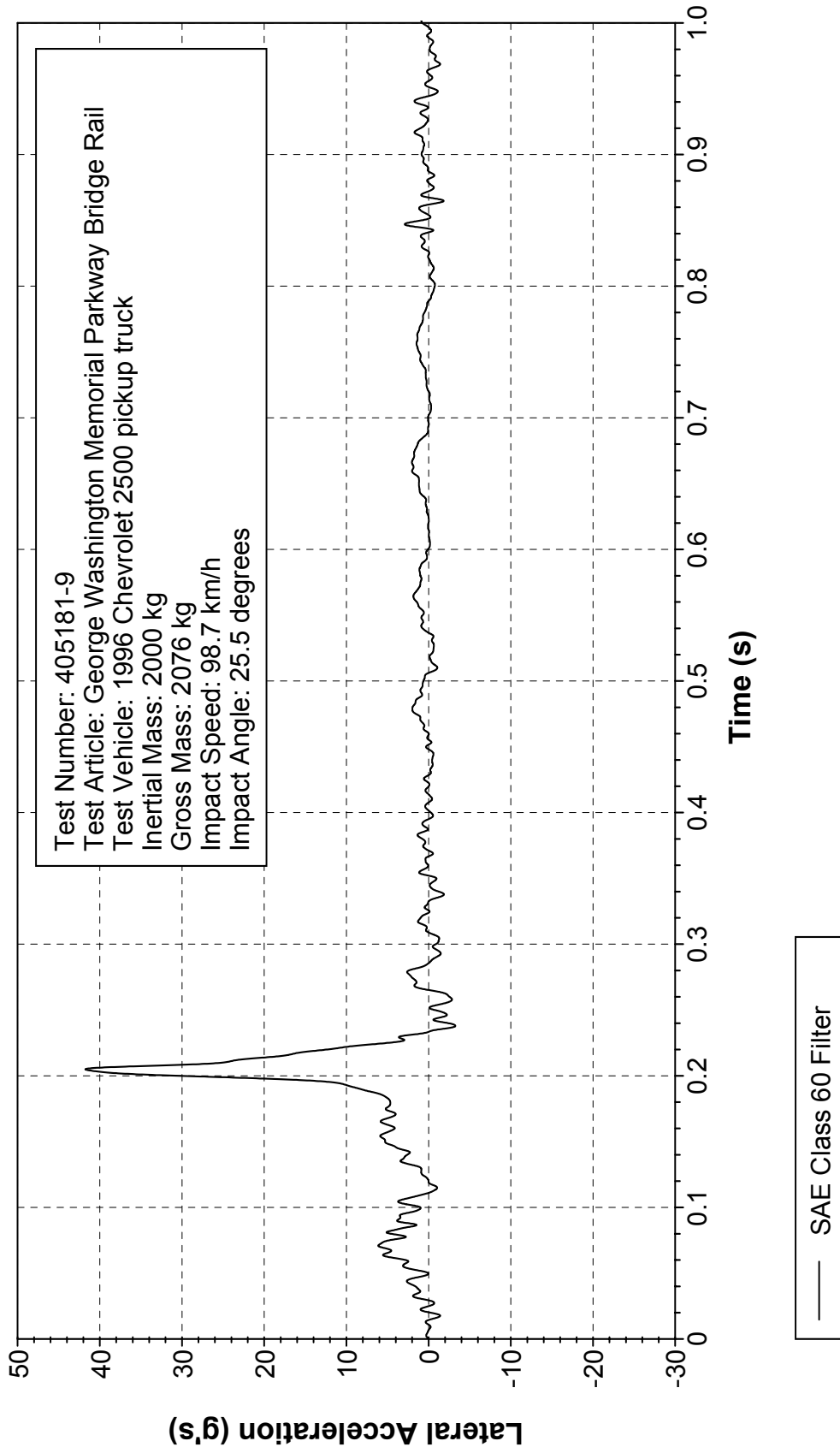

Figure 312. Vehicle lateral accelerometer trace for test 405181-9 (accelerometer located over rear axle).

# Z Acceleration over Rear Axle

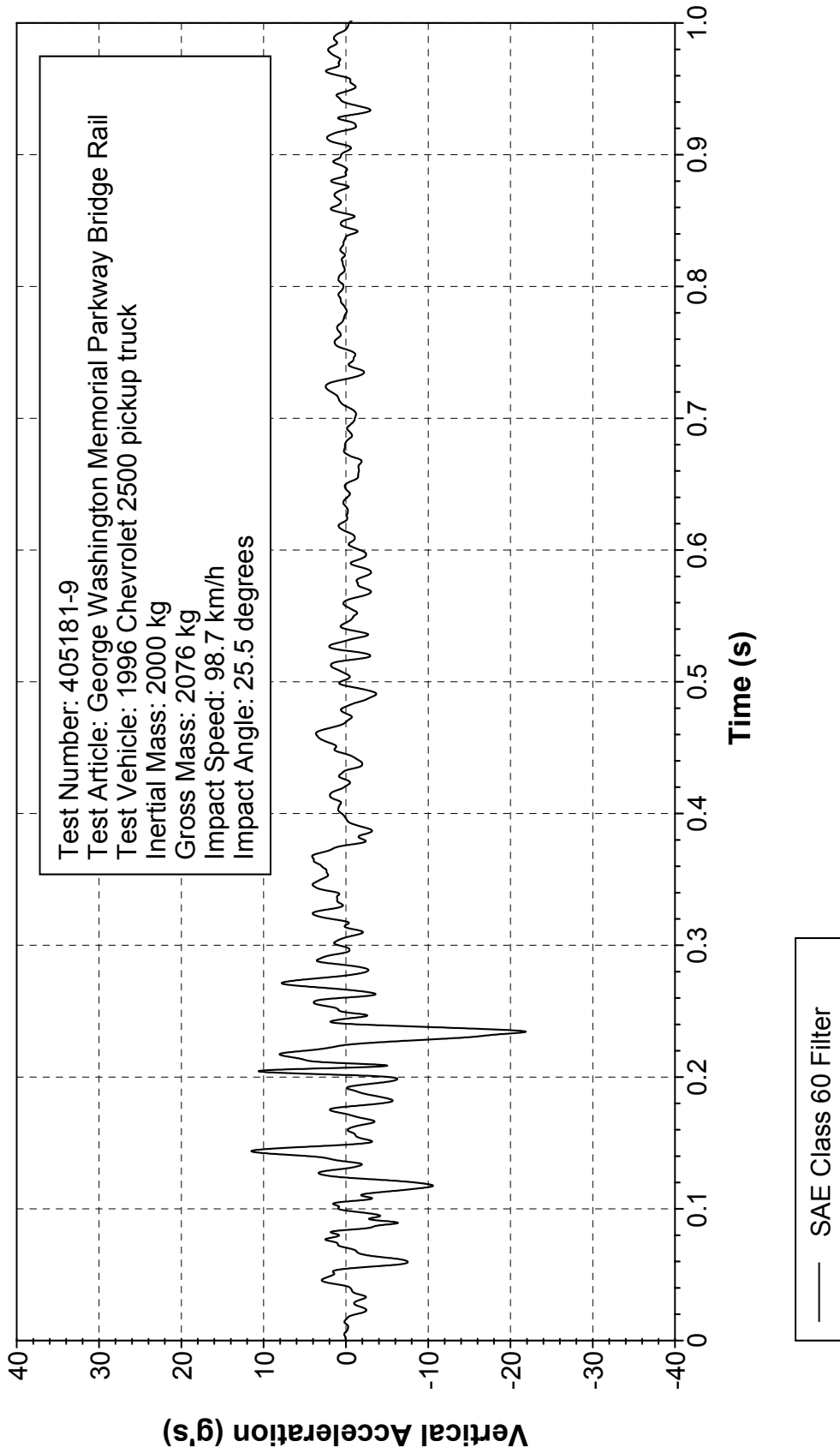

Figure 313. Vehicle vertical accelerometer trace for test 405181-9 (accelerometer located over rear axle).



# Roll, Pitch, and Yaw Angles

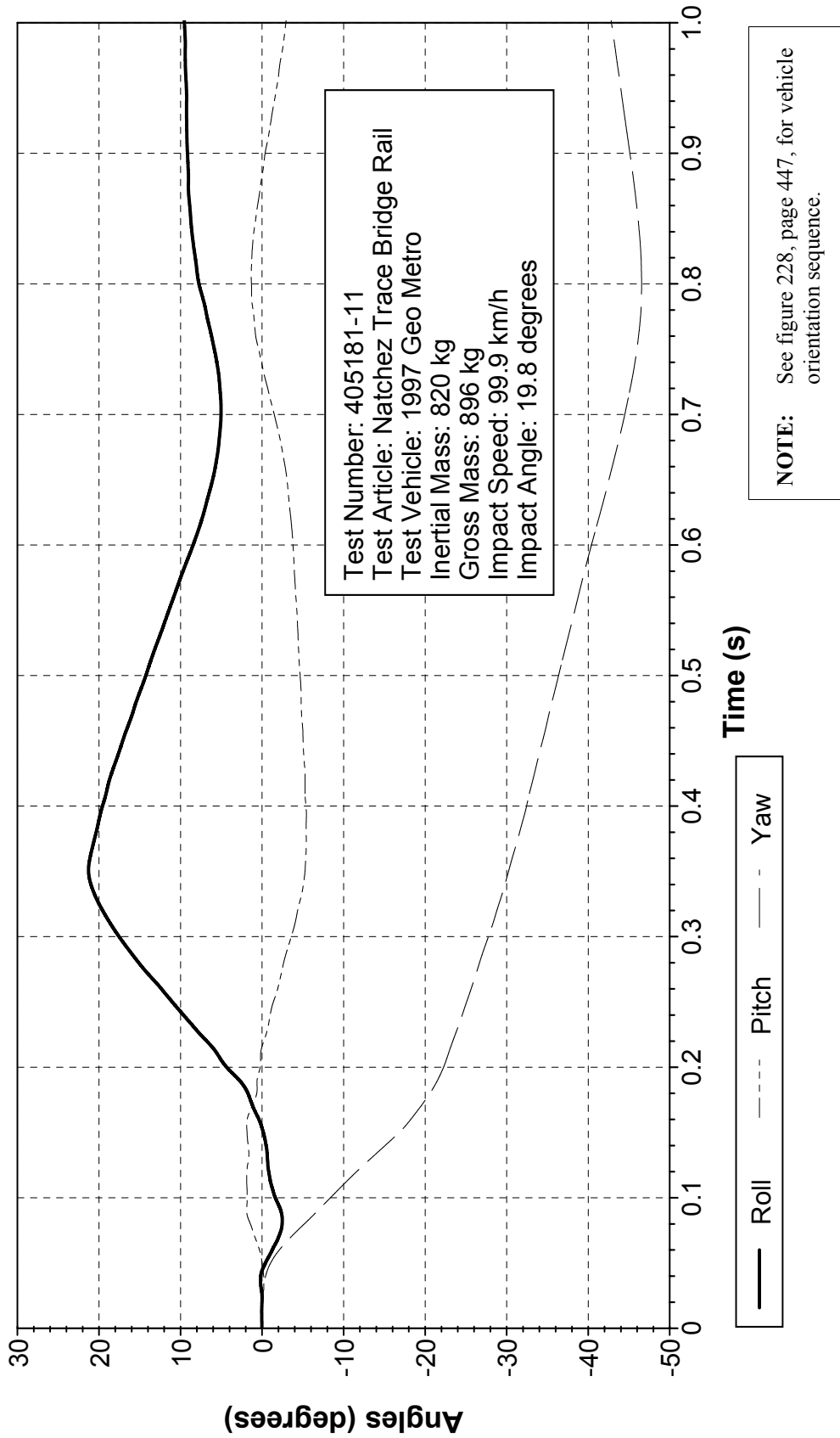

Figure 314. Vehicle angular displacements for test 405181-11.

# X Acceleration at C.G.

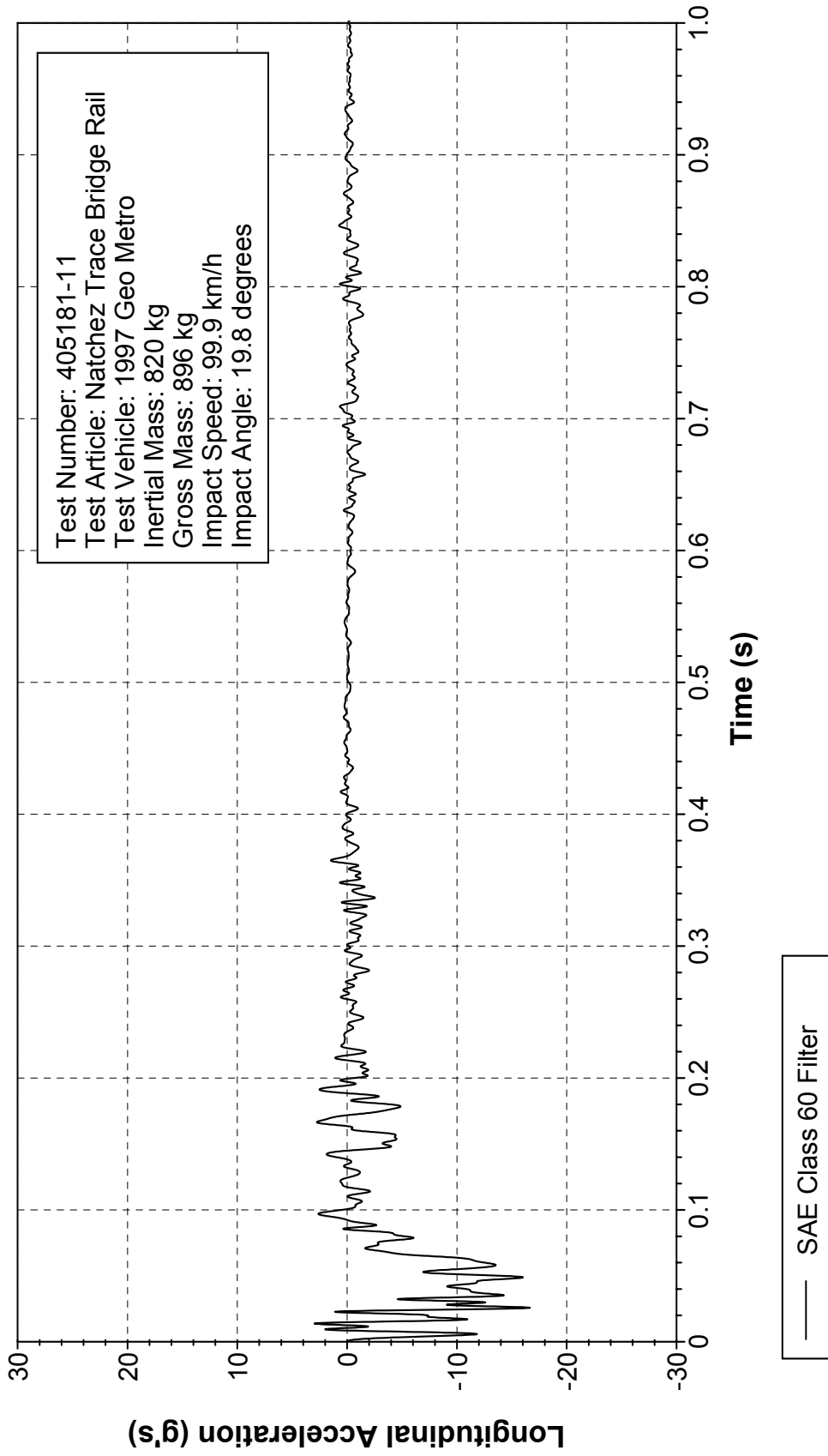

Figure 315. Vehicle longitudinal accelerometer trace for test 405181-11 (accelerometer located at center of gravity).

# Y Acceleration at C.G.

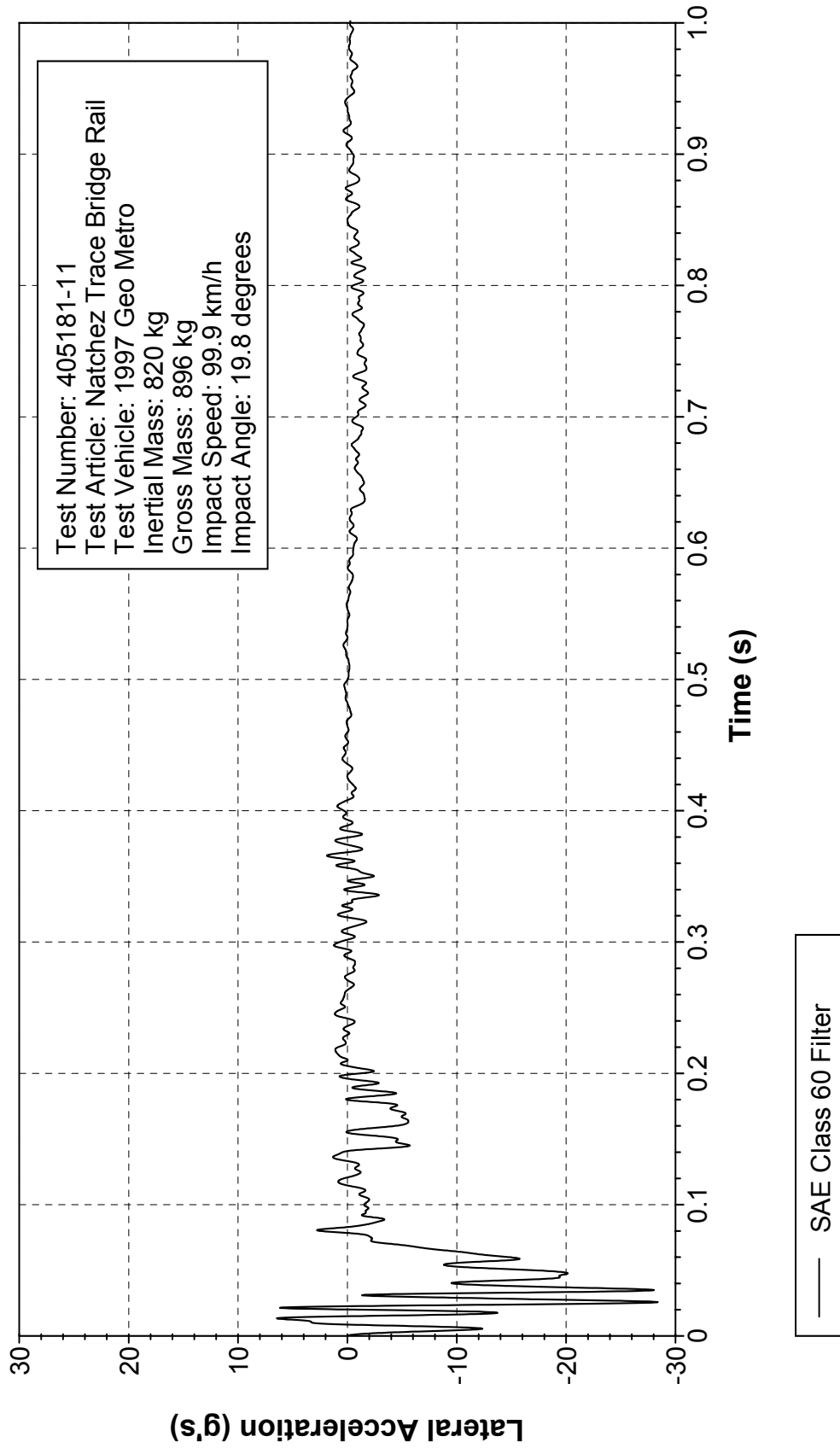

Figure 316. Vehicle lateral accelerometer trace for test 405181-11 (accelerometer located at center of gravity).

# Z Acceleration at C.G.

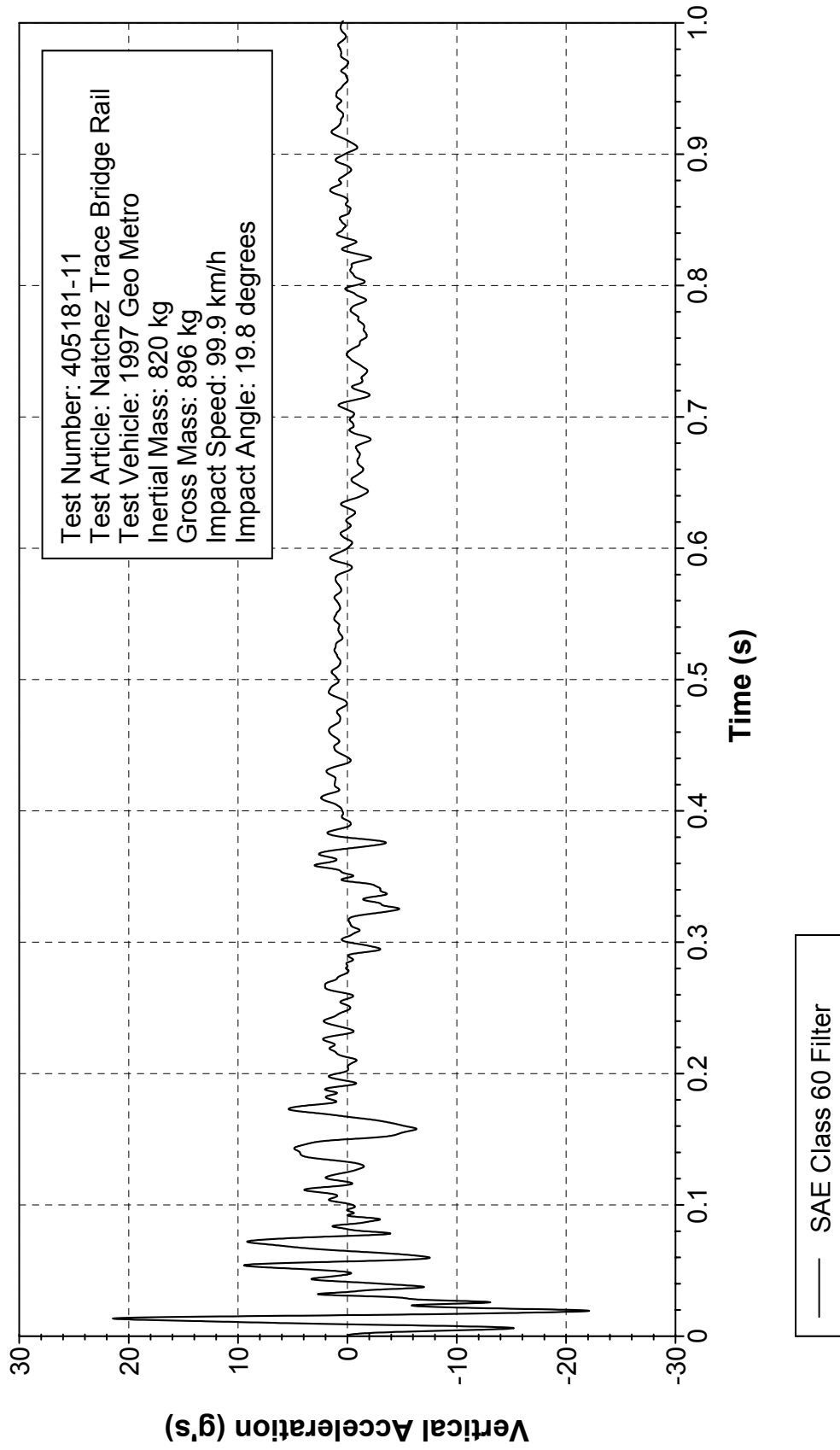

Figure 317. Vehicle vertical accelerometer trace for test 405181-11 (accelerometer located at center of gravity).

# X Acceleration over Rear Axle

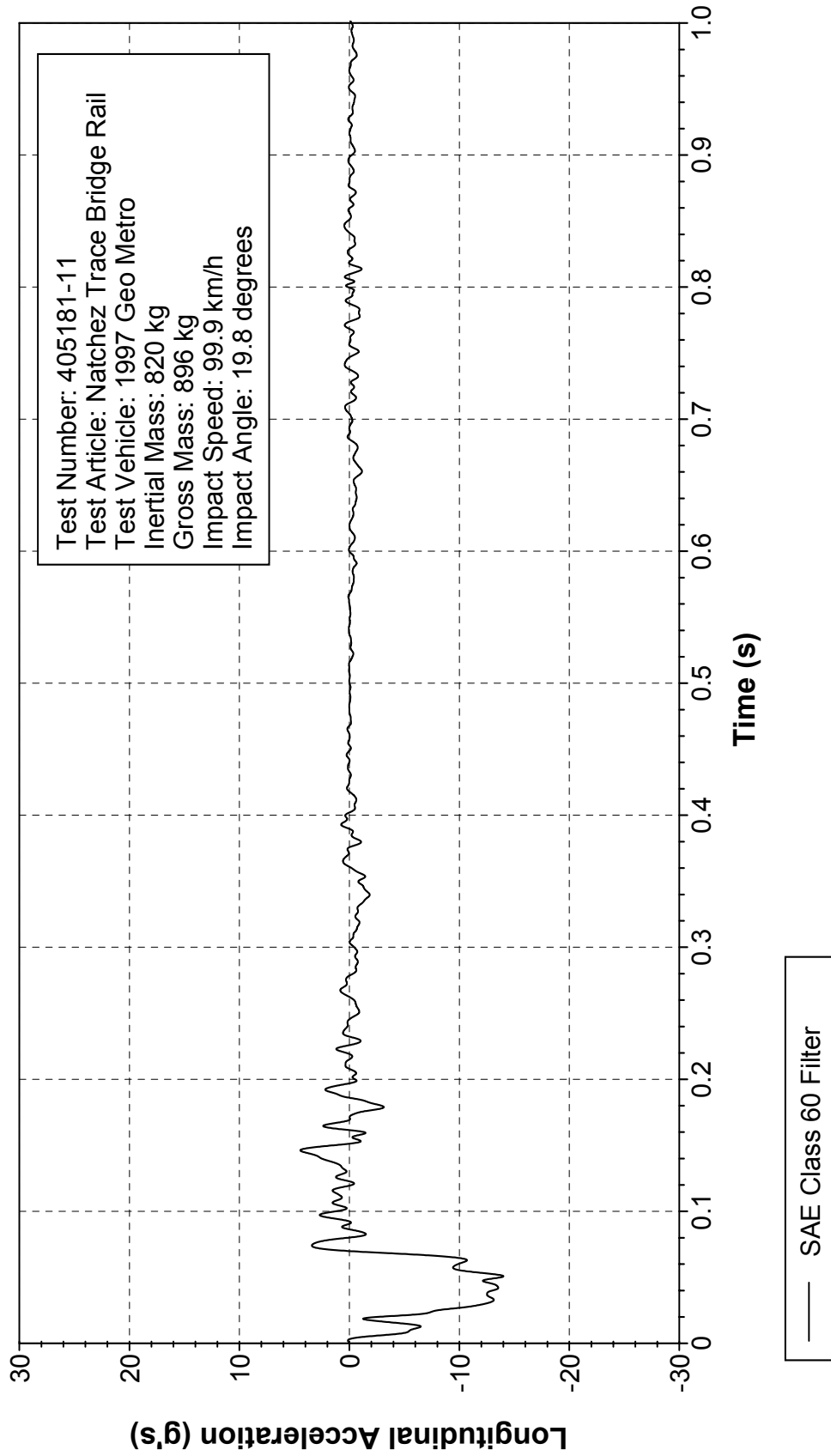

Figure 318. Vehicle longitudinal accelerometer trace for test 405181-11 (accelerometer located over rear axle).

# Y Acceleration over Rear Axle

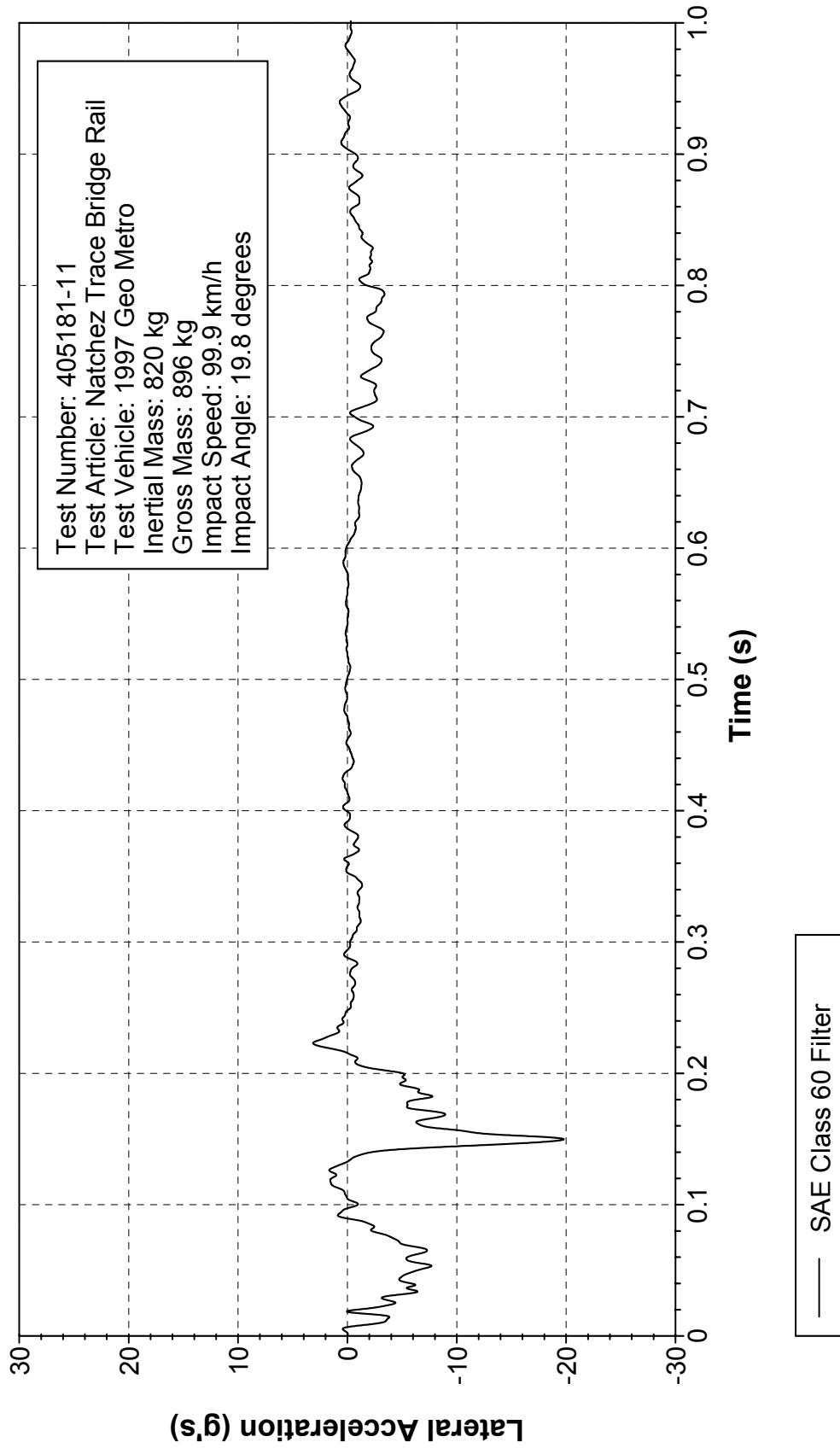

Figure 319. Vehicle lateral accelerometer trace for test 405181-11 (accelerometer located over rear axle).

# Z Acceleration over Rear Axle

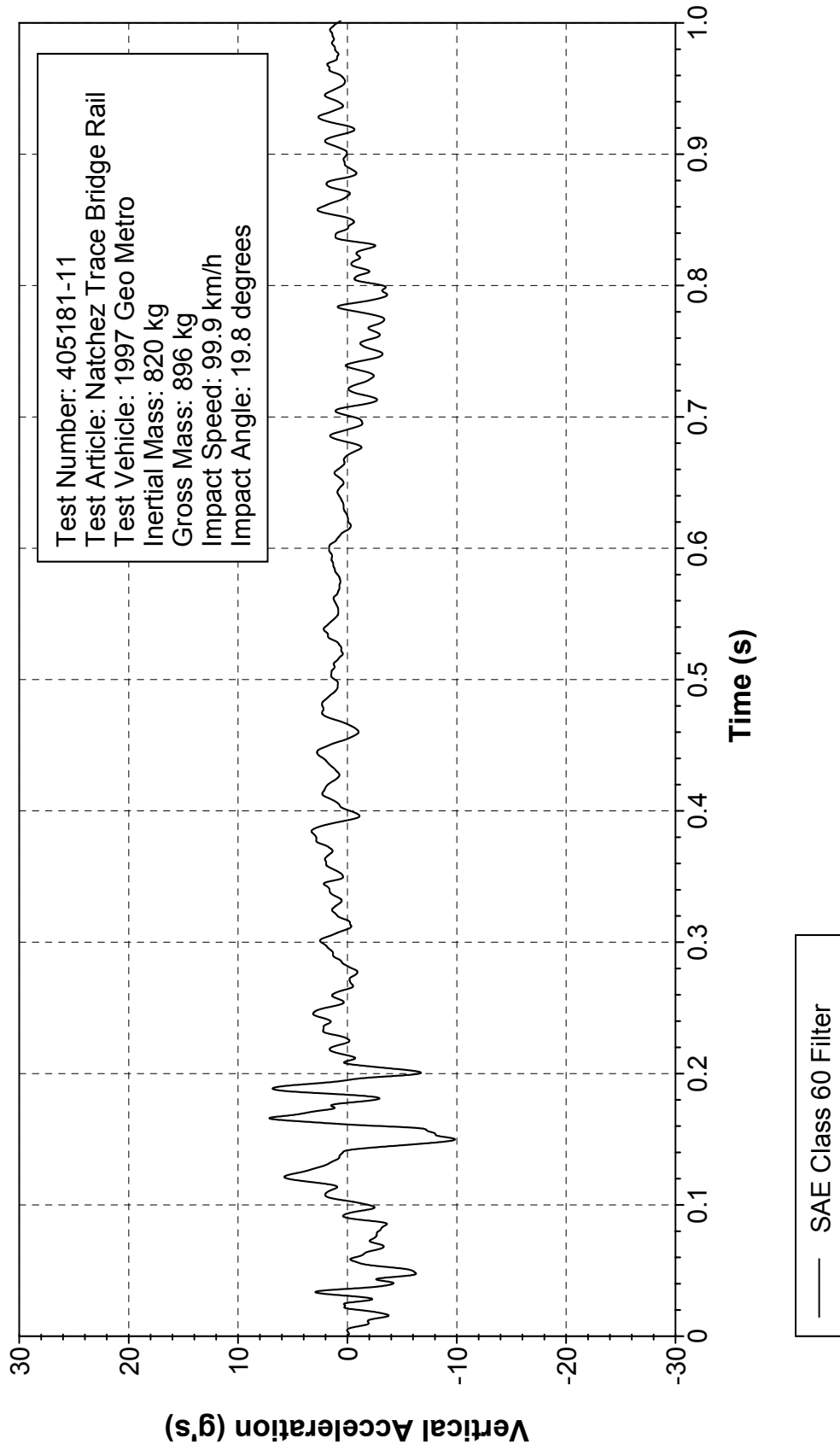

Figure 320. Vehicle vertical accelerometer trace for test 405181-11 (accelerometer located over rear axle).

# Roll, Pitch, and Yaw Angles

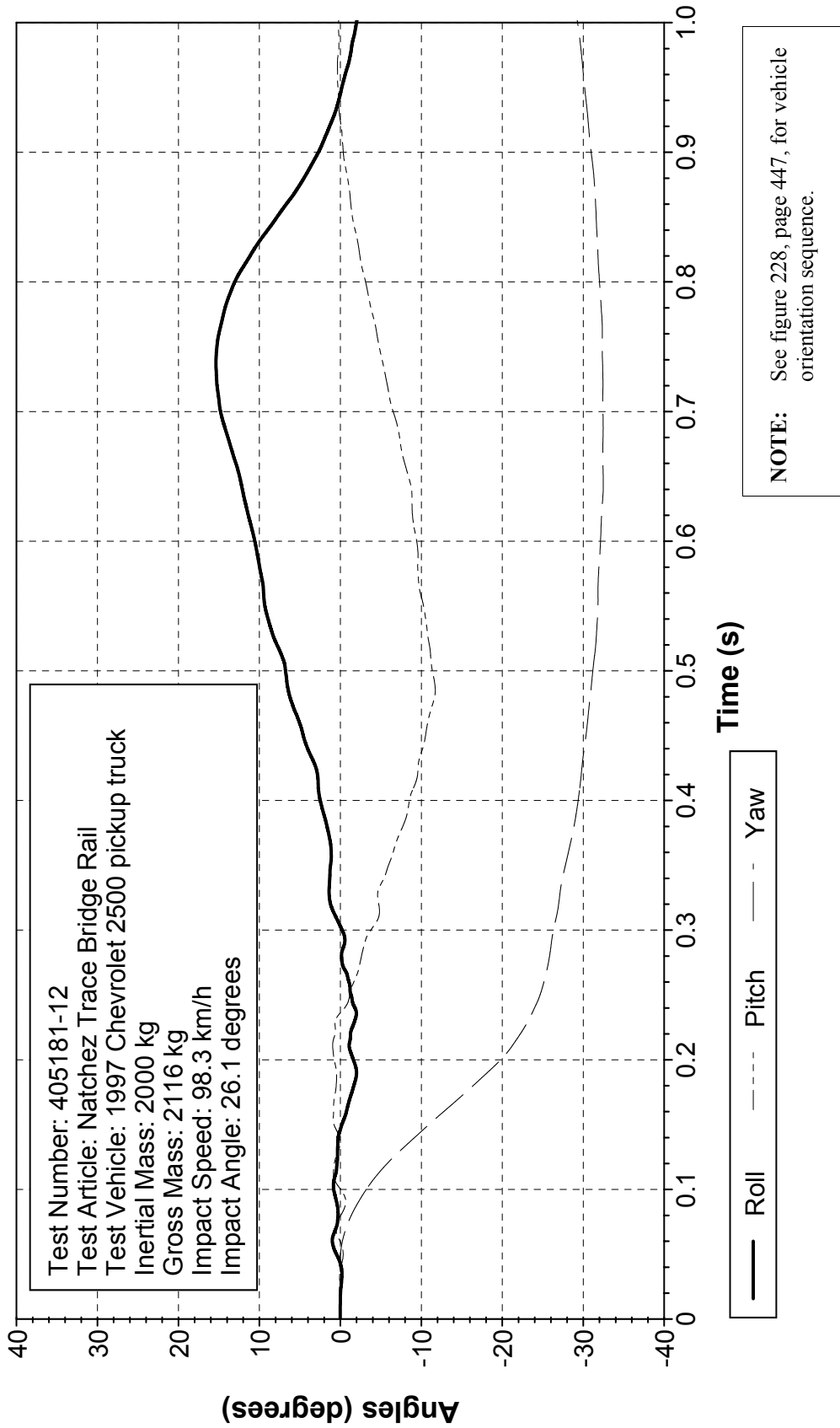

Figure 321. Vehicle angular displacements for test 405181-12.



# X Acceleration at C.G.

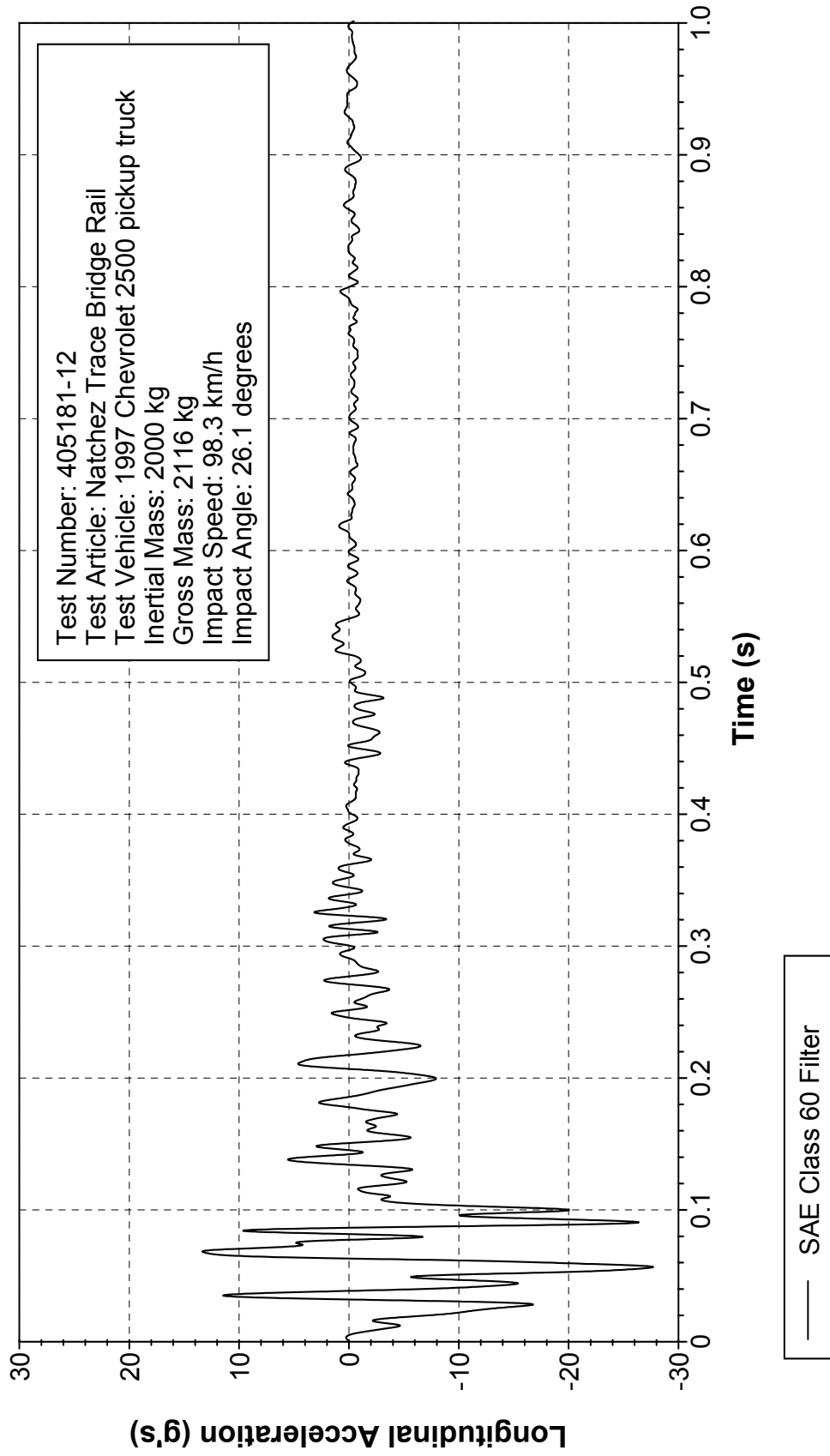

Figure 322. Vehicle longitudinal accelerometer trace for test 405181-12 (accelerometer located at center of gravity).

# Y Acceleration at C.G.

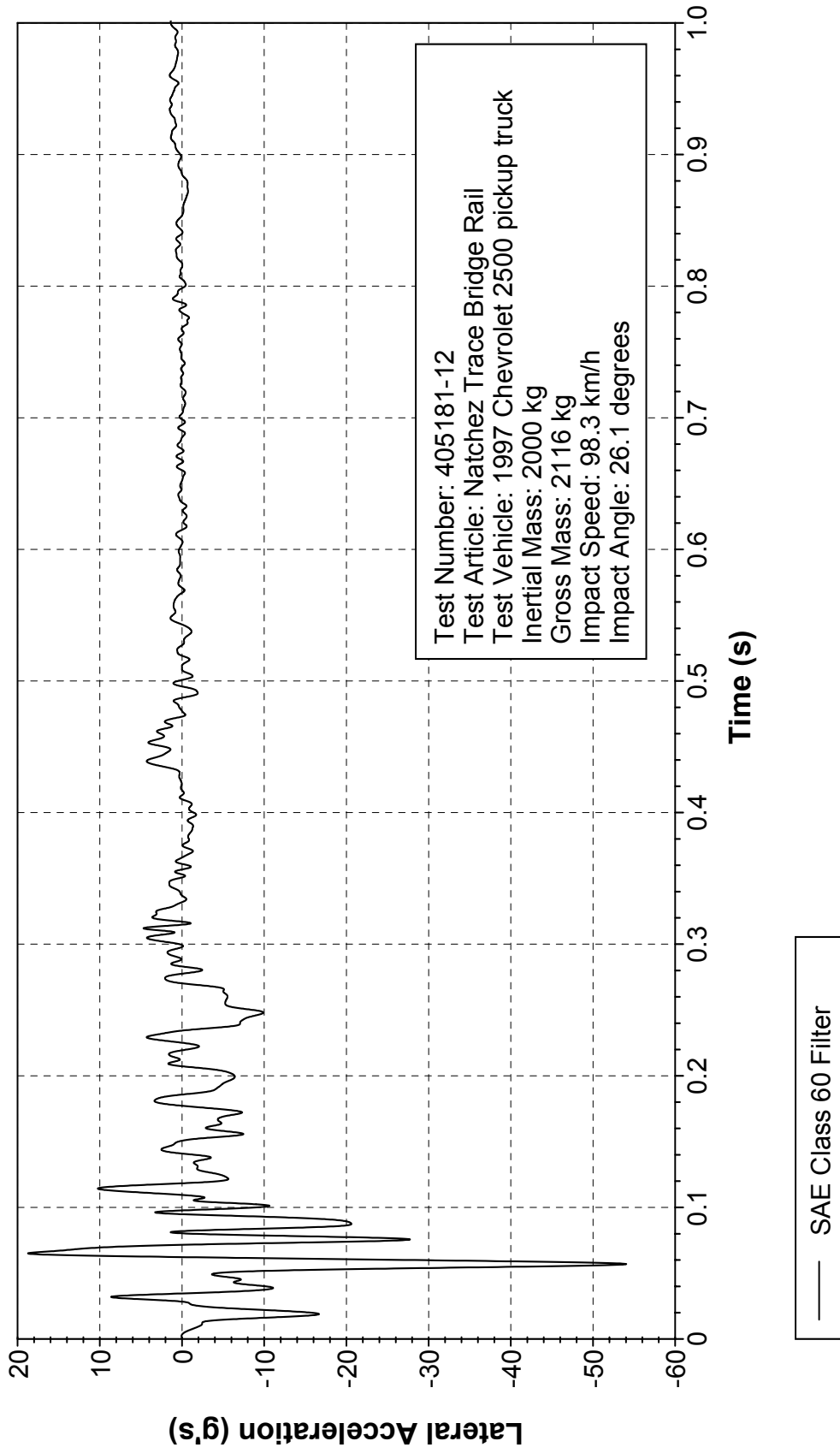

Figure 323. Vehicle lateral accelerometer trace for test 405181-12 (accelerometer located at center of gravity).

# Z Acceleration at C.G.

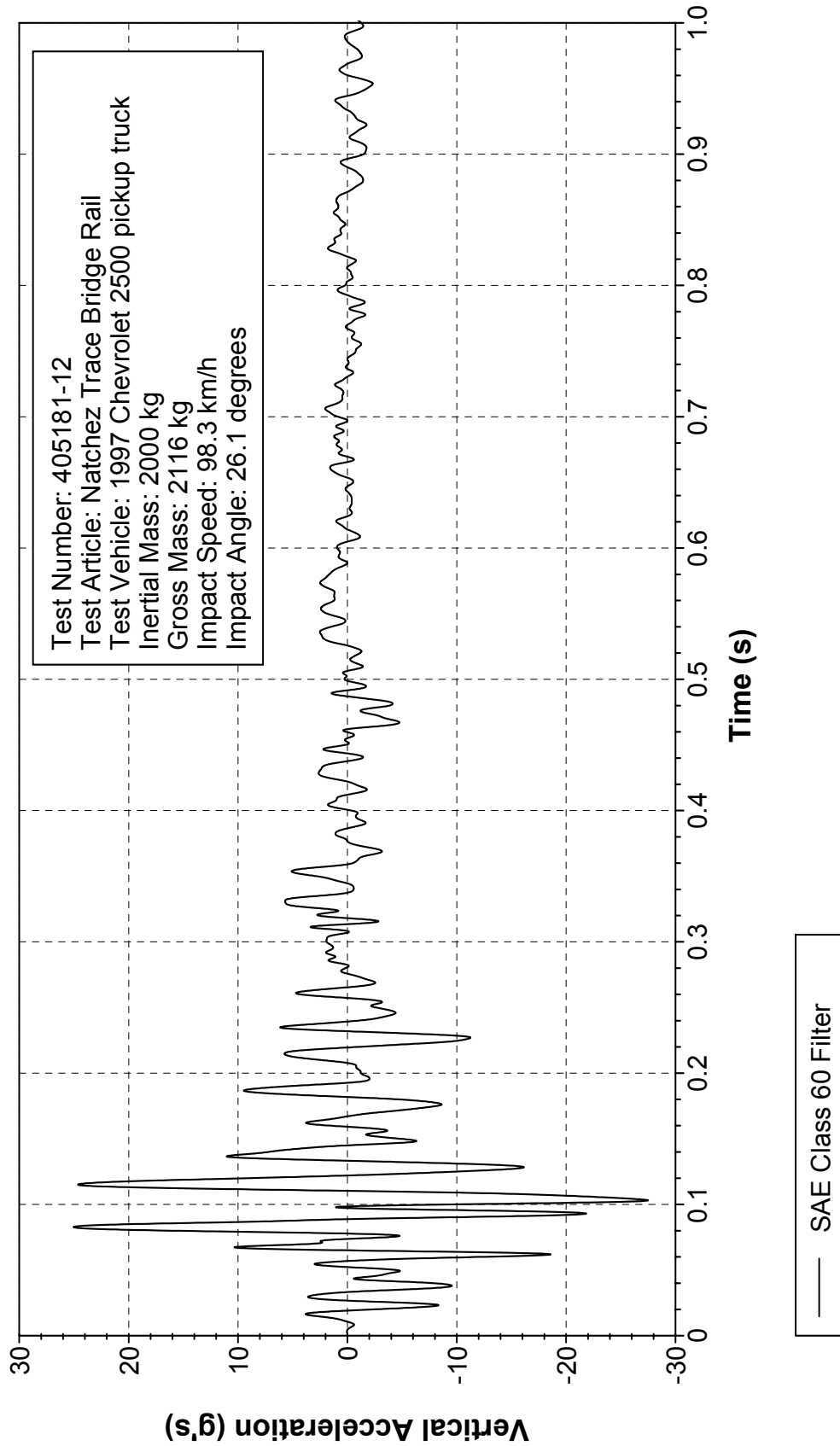

Figure 324. Vehicle vertical accelerometer trace for test 405181-12 (accelerometer located at center of gravity).

# X Acceleration over Rear Axle

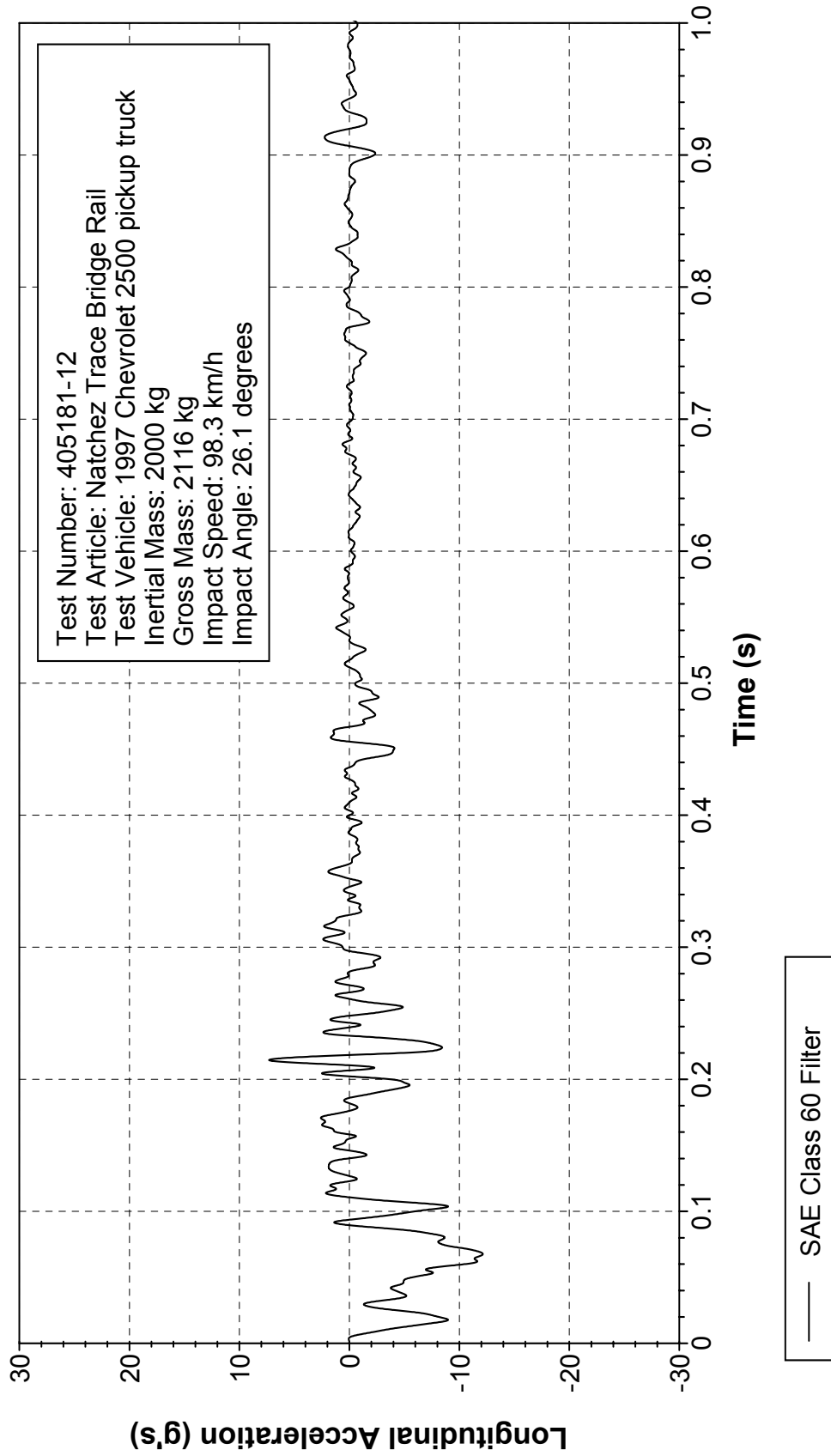

Figure 325. Vehicle longitudinal accelerometer trace for test 405181-12 (accelerometer located over rear axle).

# Y Acceleration over Rear Axle

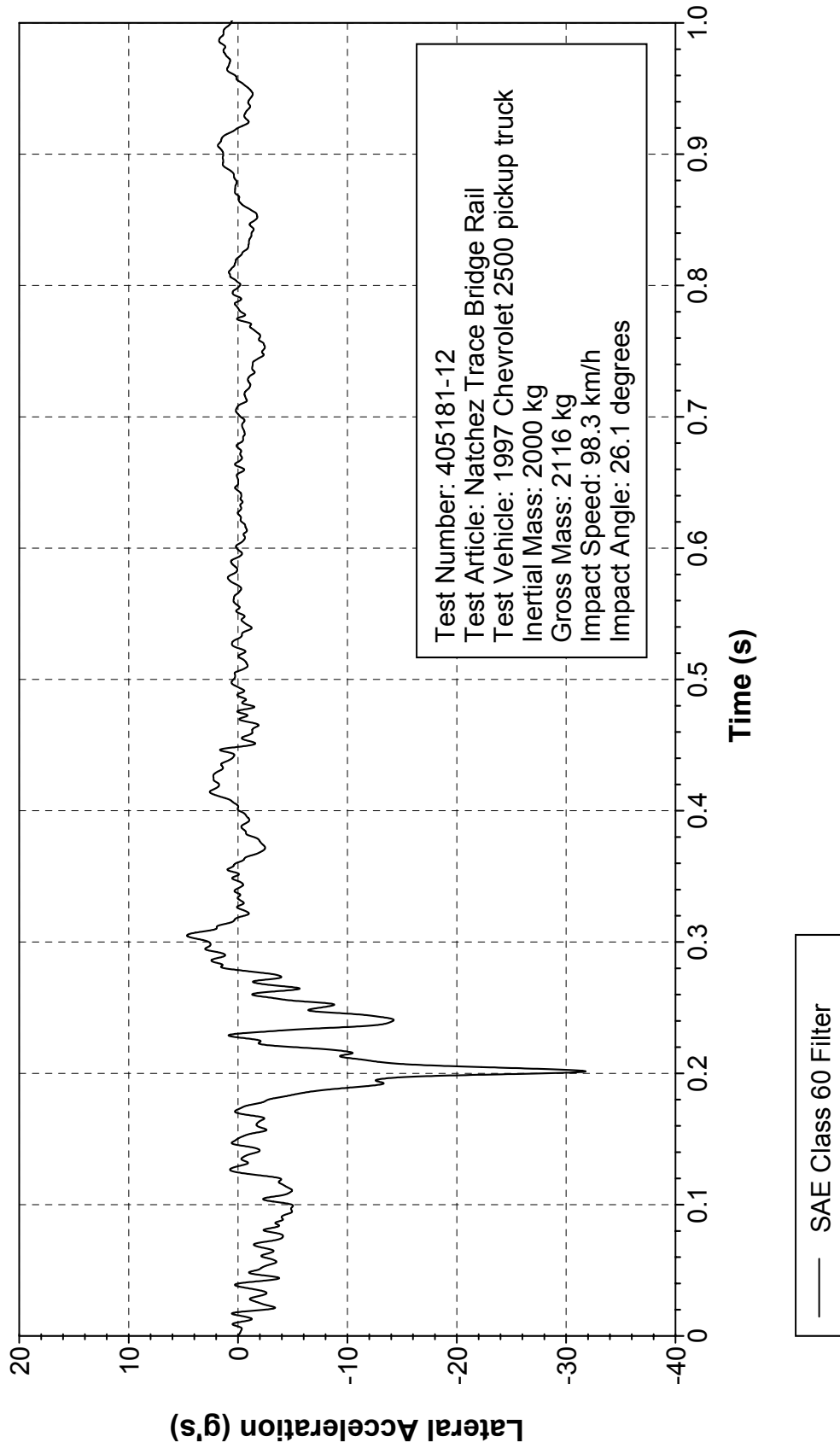

Figure 326. Vehicle lateral accelerometer trace for test 405181-12 (accelerometer located over rear axle).

# Z Acceleration over Rear Axle

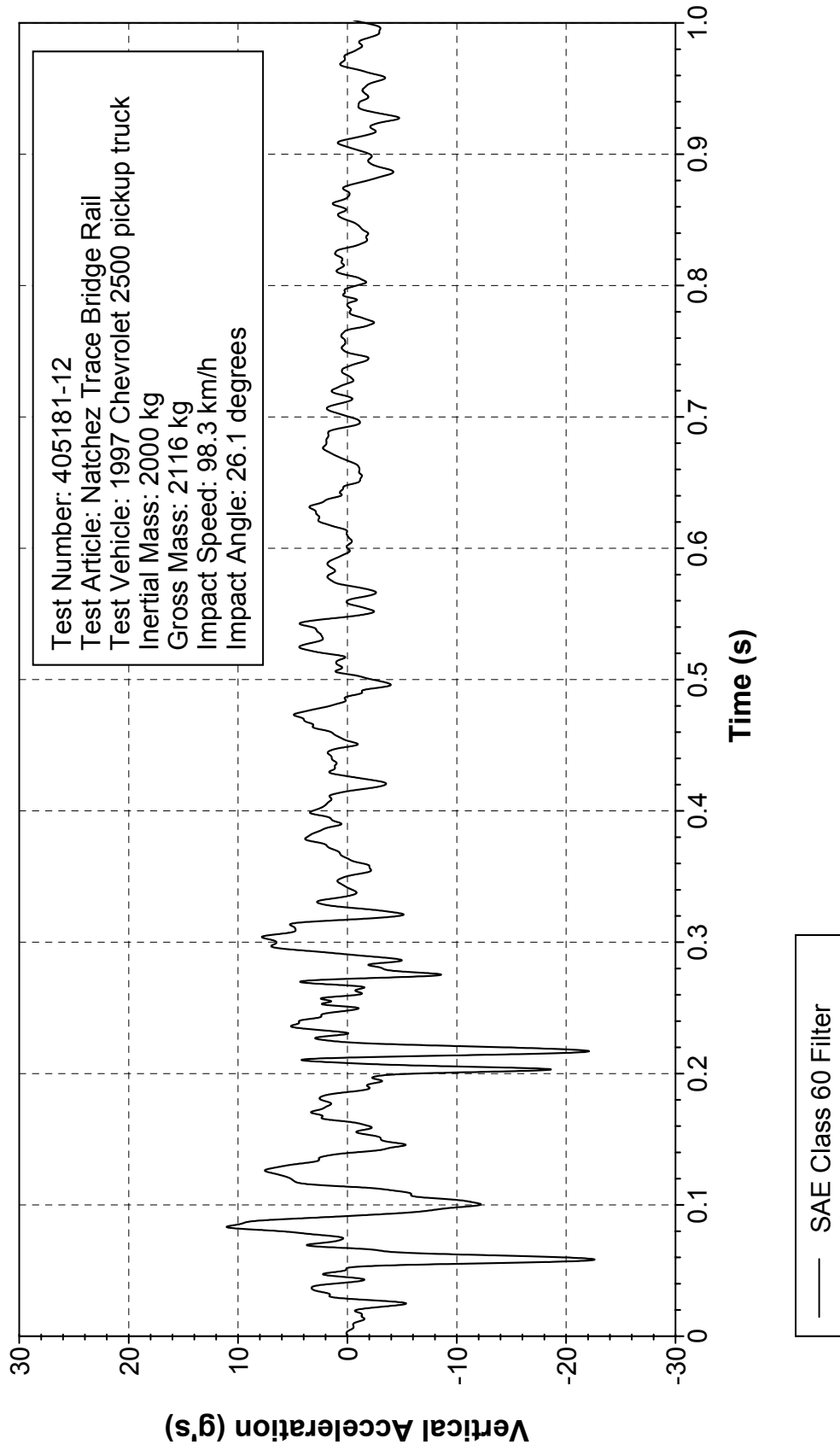

Figure 327. Vehicle vertical accelerometer trace for test 405181-12 (accelerometer located over rear axle).

# Roll, Pitch, and Yaw Angles

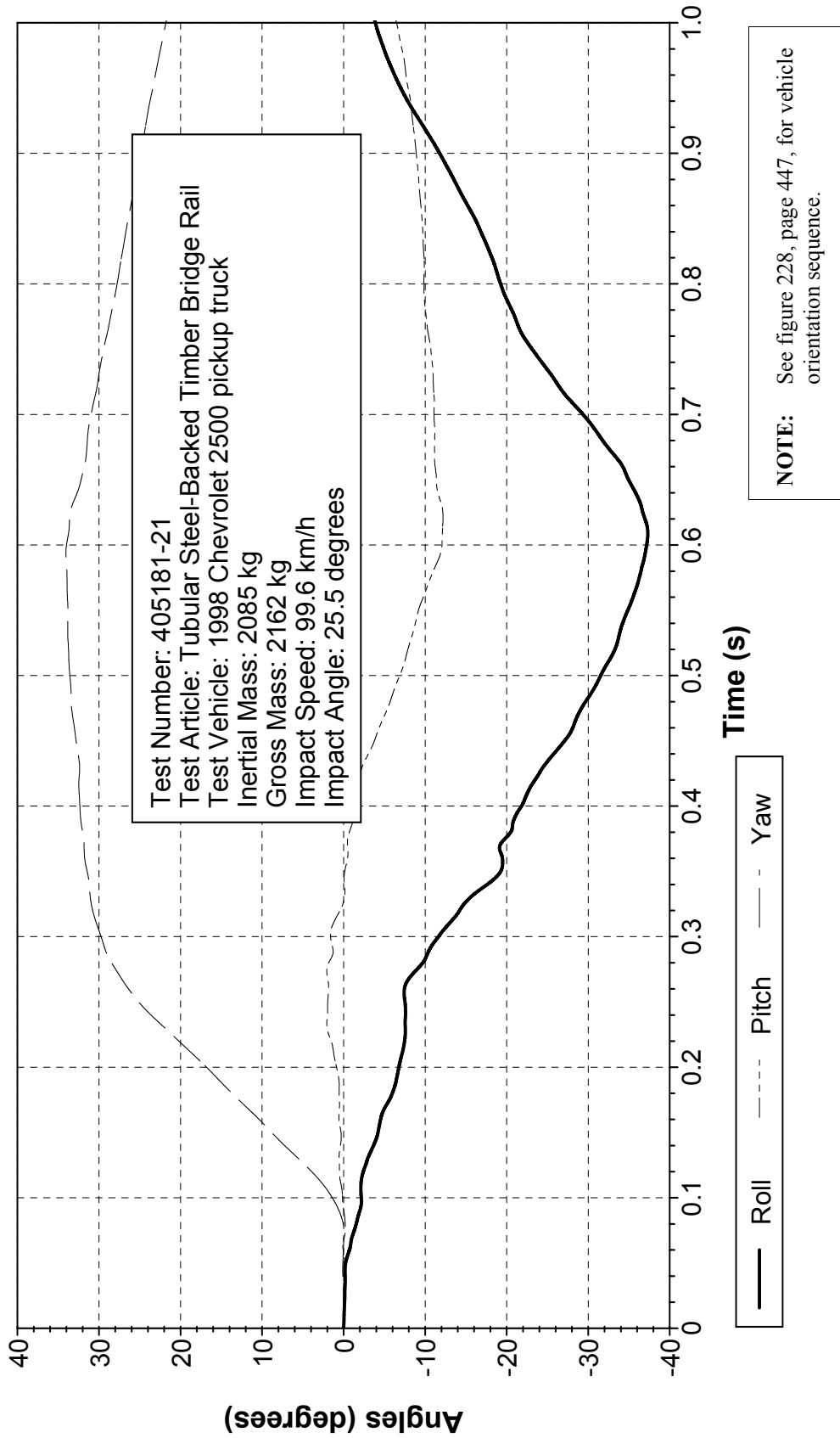

Figure 328. Vehicle angular displacements for test 405181-21.

# X Acceleration at C.G.

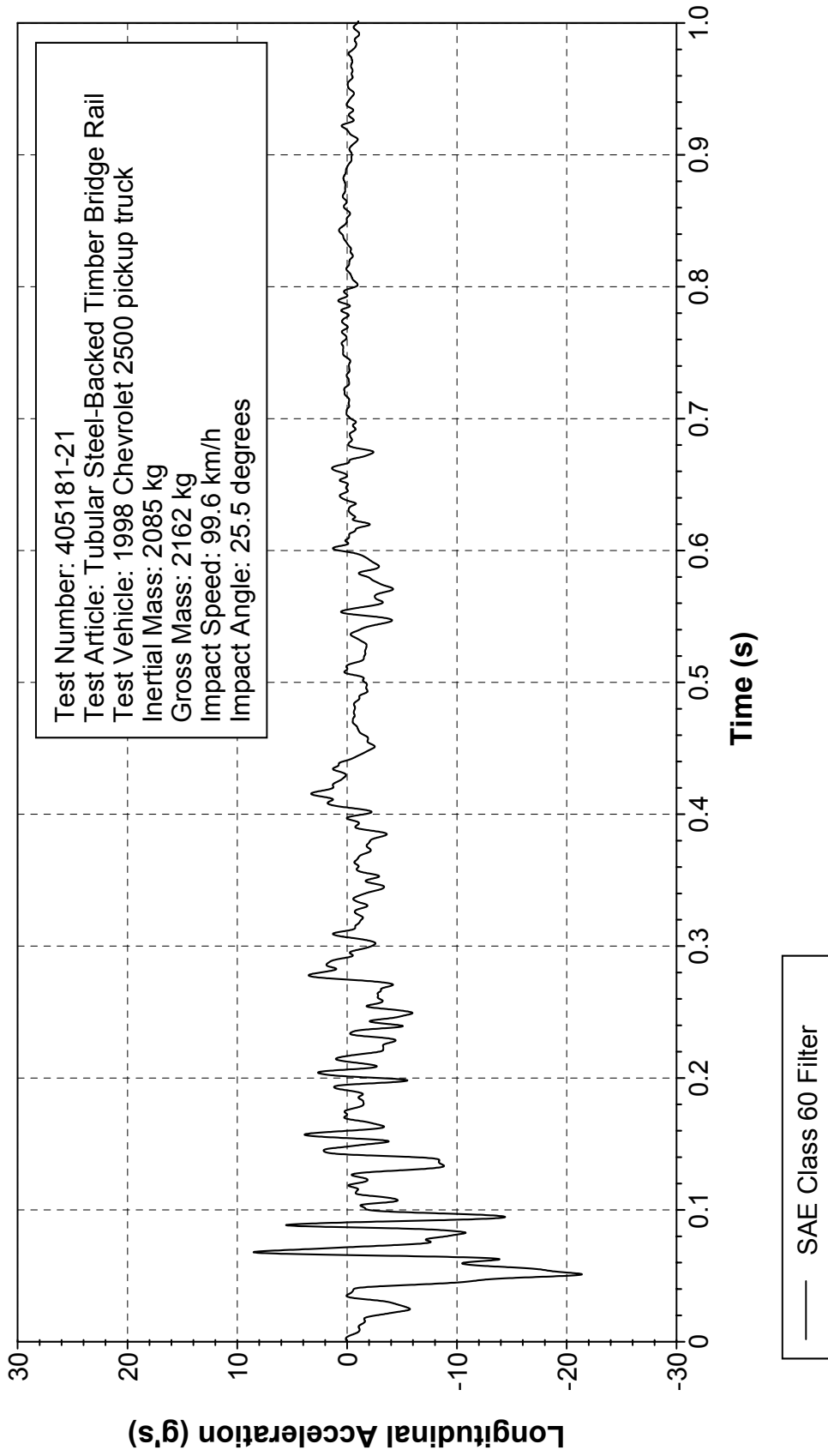

Figure 329. Vehicle longitudinal accelerometer trace for test 405181-21 (accelerometer located at center of gravity).



# Y Acceleration at C.G.

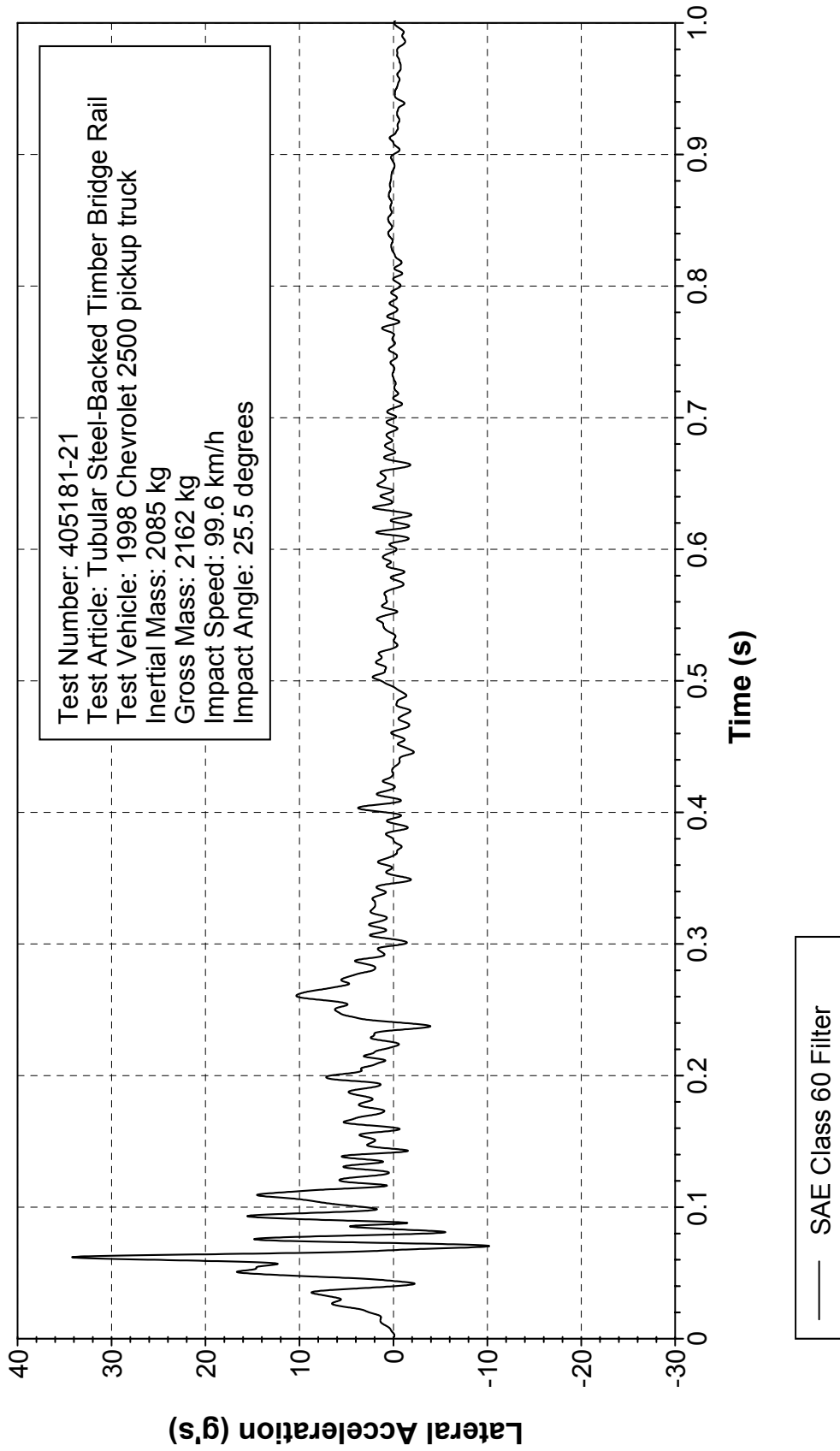

Figure 330. Vehicle lateral accelerometer trace for test 405181-21 (accelerometer located at center of gravity).

## Z Acceleration at C.G.

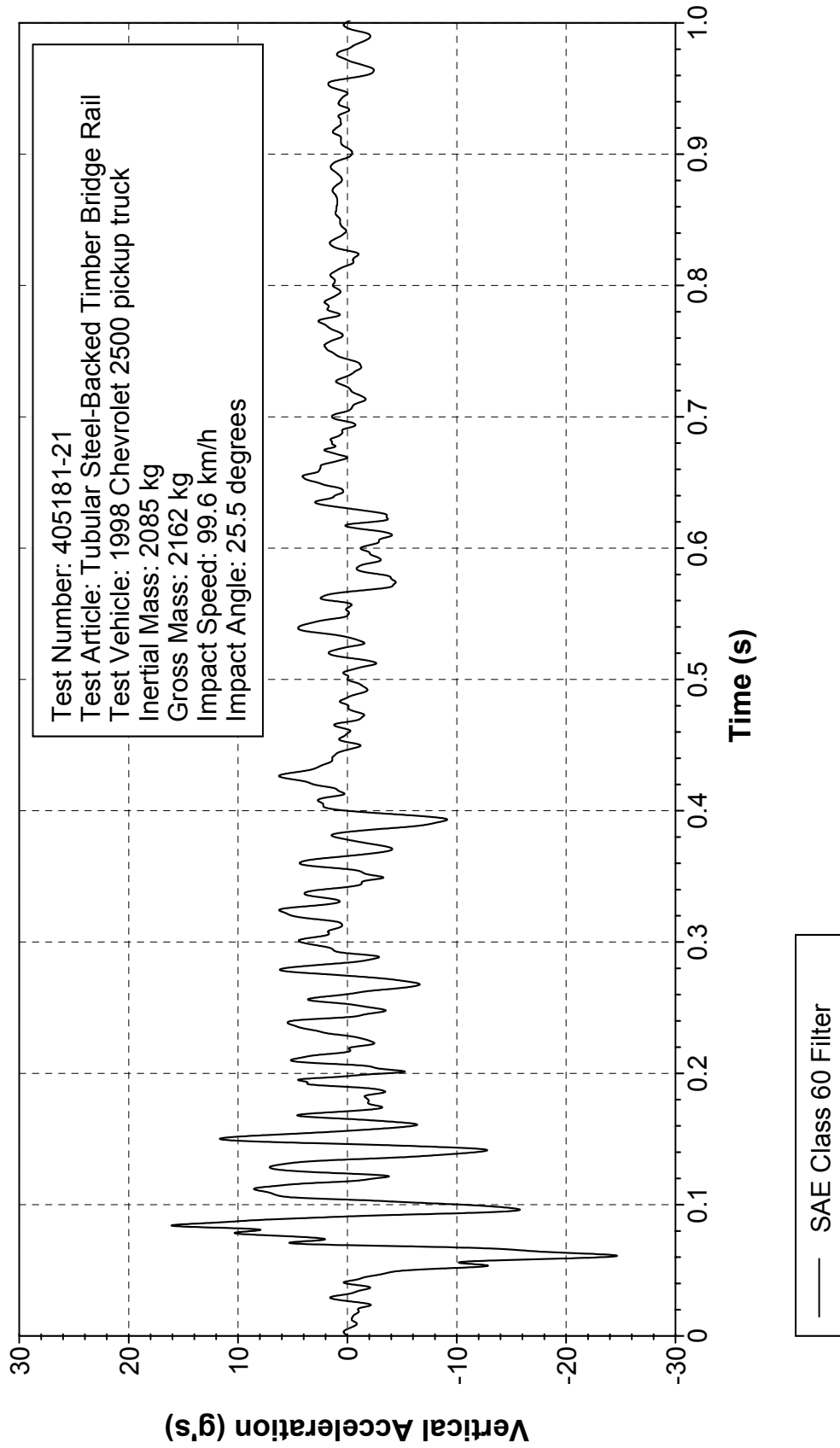

Figure 331. Vehicle vertical accelerometer trace for test 405181-21 (accelerometer located at center of gravity).

# X Acceleration over Rear Axle

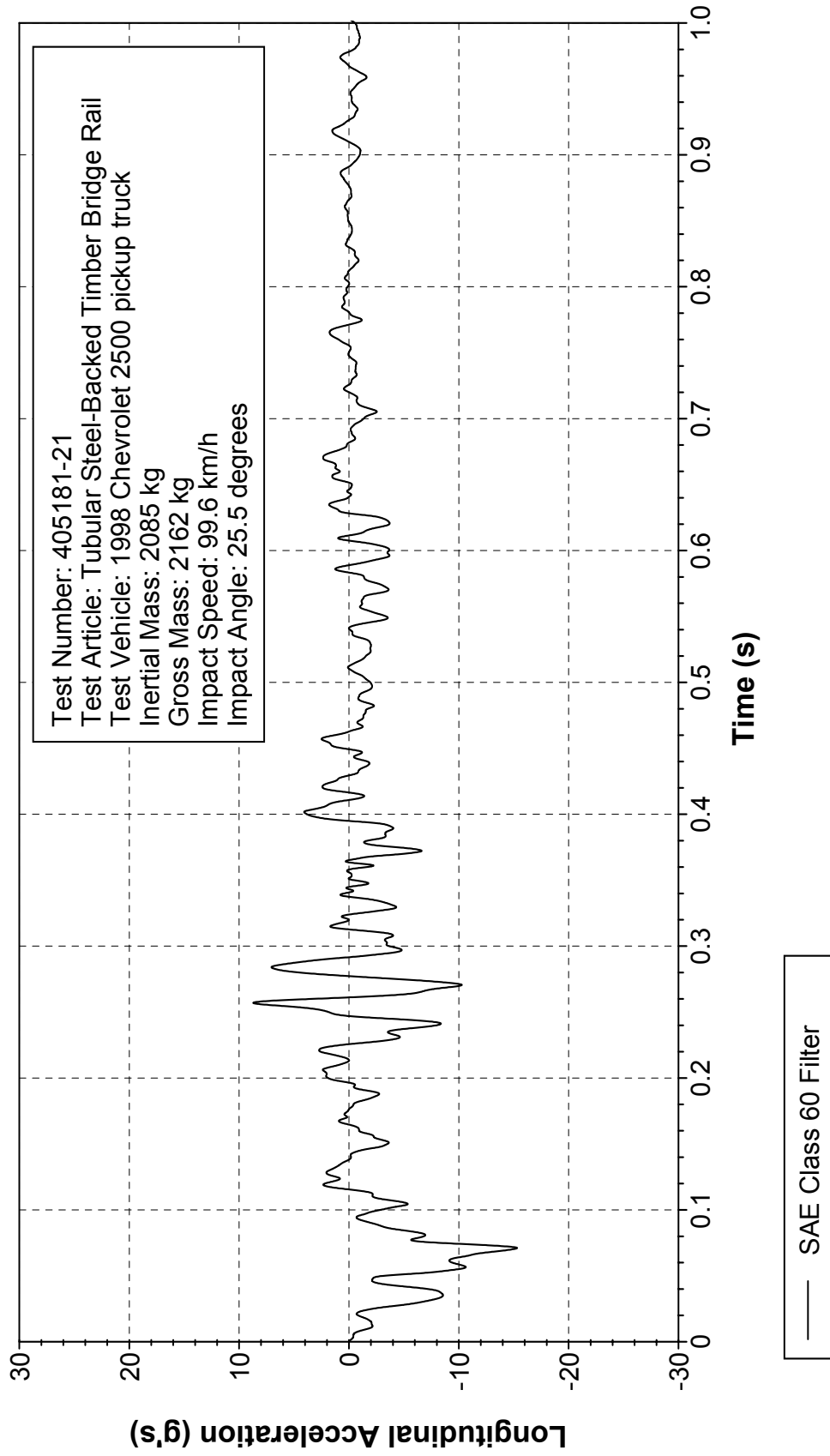

Figure 332. Vehicle longitudinal accelerometer trace for test 405181-21 (accelerometer located over rear axle).

# Y Acceleration over Rear Axle

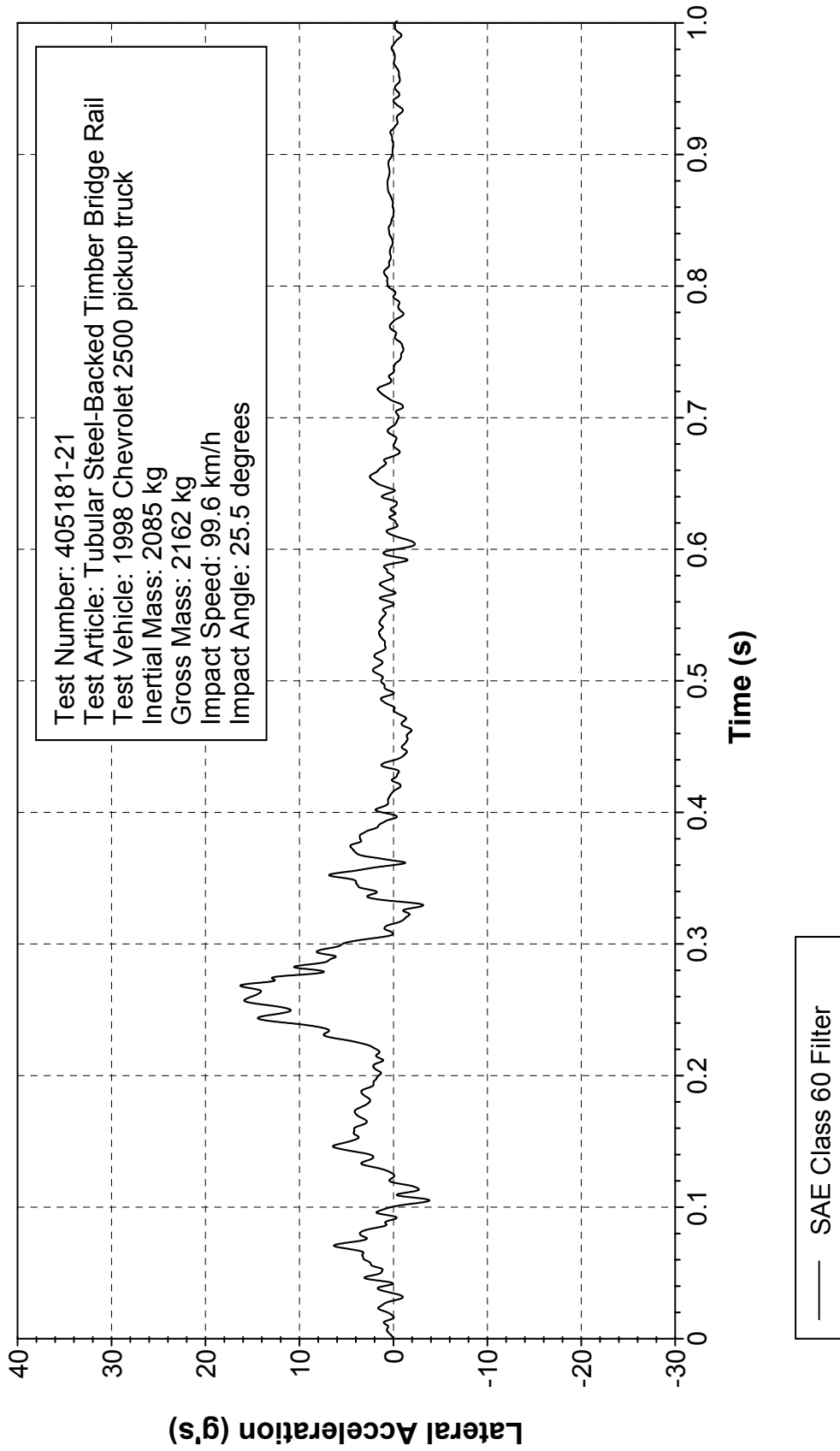

Figure 333. Vehicle lateral accelerometer trace for test 405181-21 (accelerometer located over rear axle).

# Z Acceleration over Rear Axle

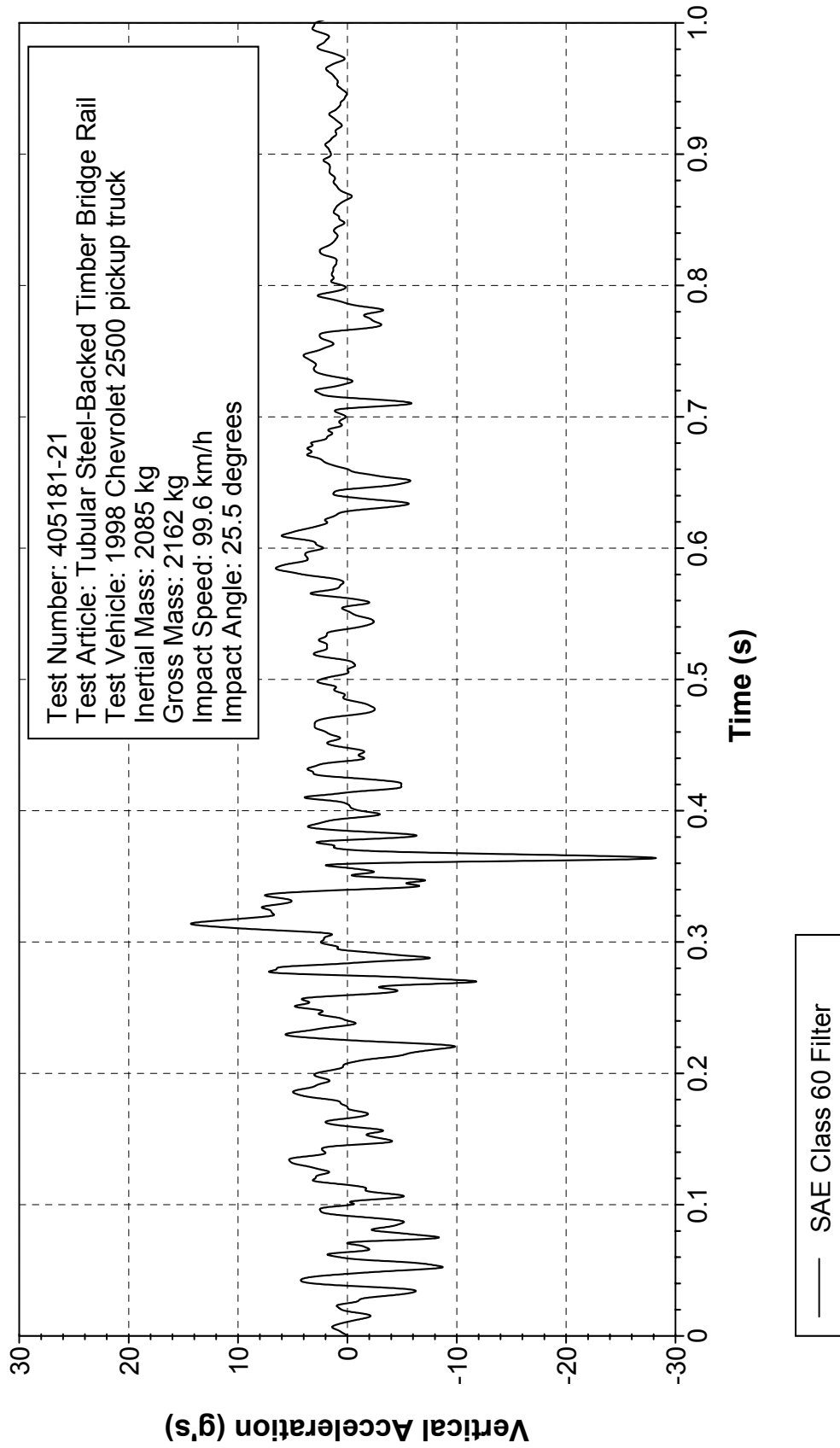

Figure 334. Vehicle vertical accelerometer trace for test 405181-21 (accelerometer located over rear axle).

# Roll, Pitch, and Yaw Angles

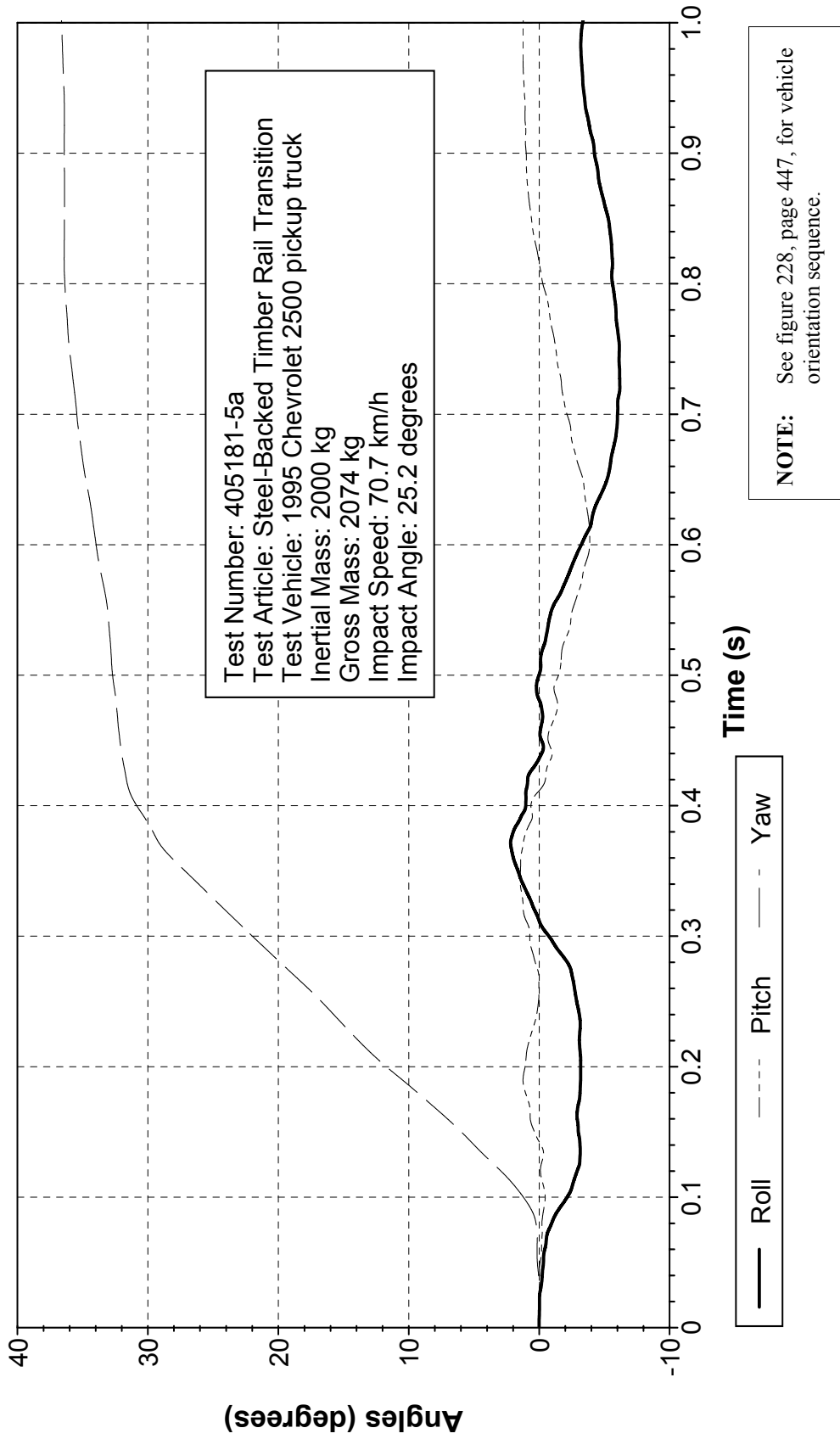

Figure 335. Vehicle angular displacements for test 405181-5a.

# X Acceleration at C.G.

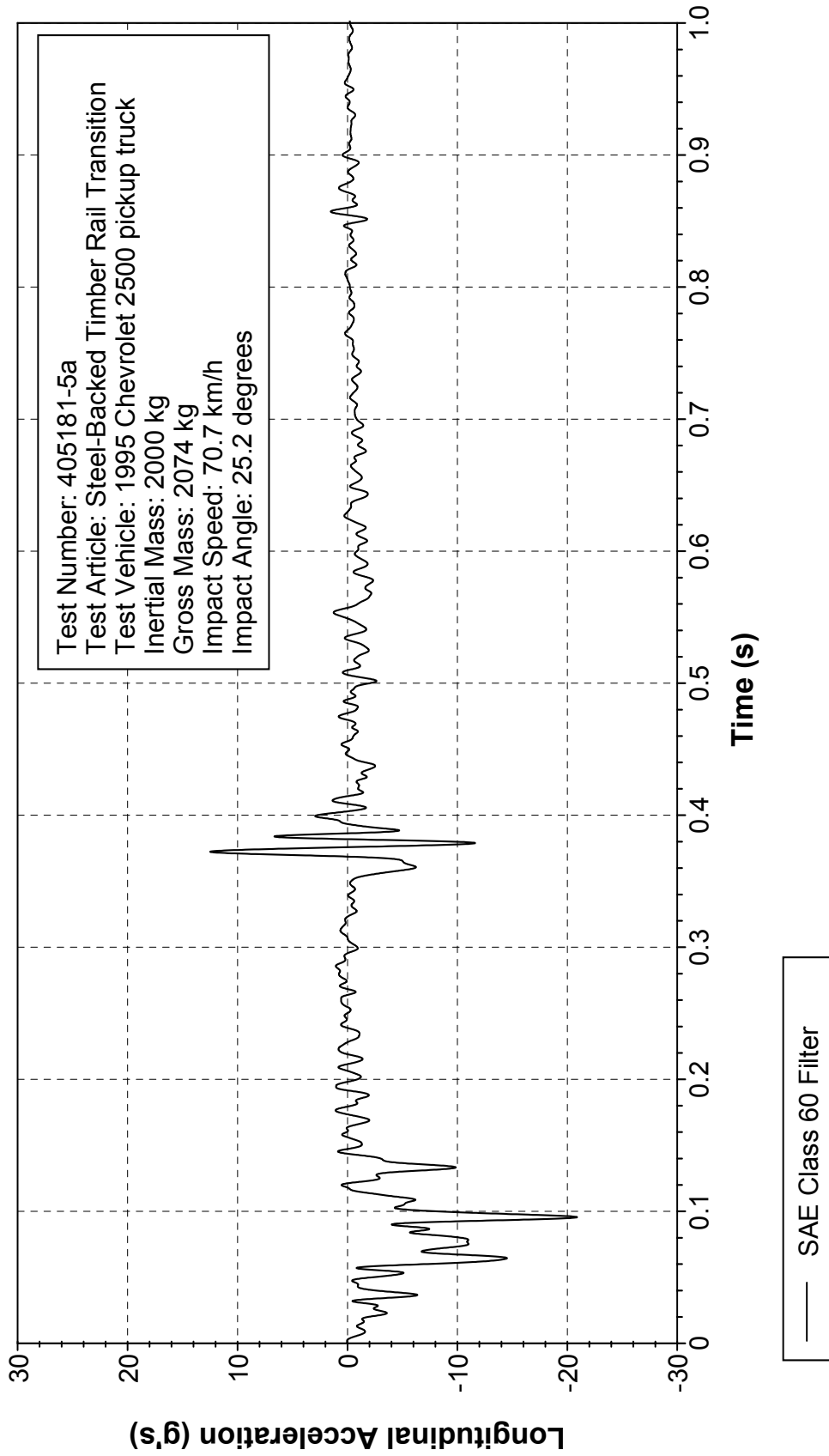

Figure 336. Vehicle longitudinal accelerometer trace for test 405181-5a (accelerometer located at center of gravity).

# Y Acceleration at C.G.

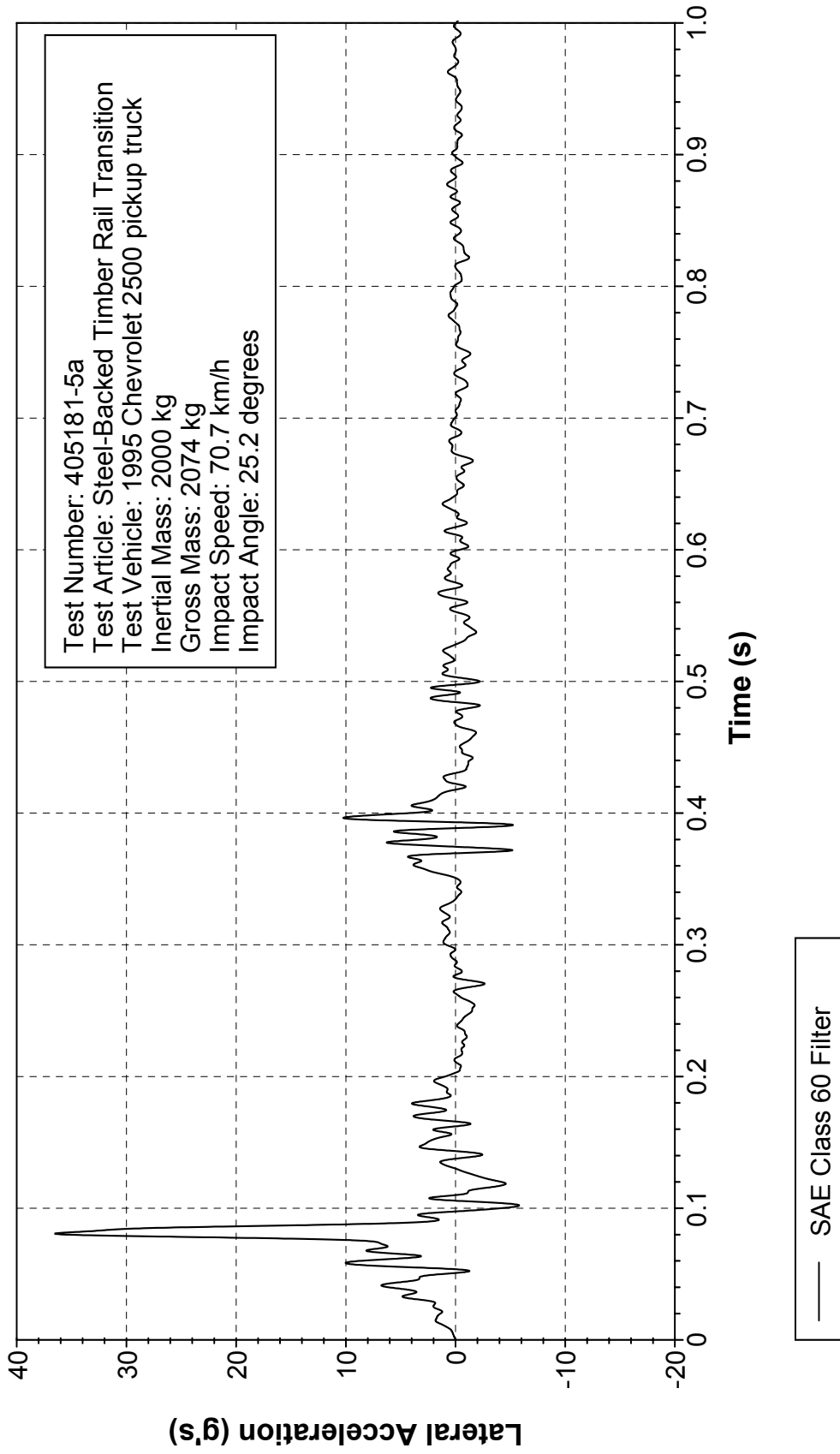

Figure 337. Vehicle lateral accelerometer trace for test 405181-5a (accelerometer located at center of gravity).



# Z Acceleration at C.G.

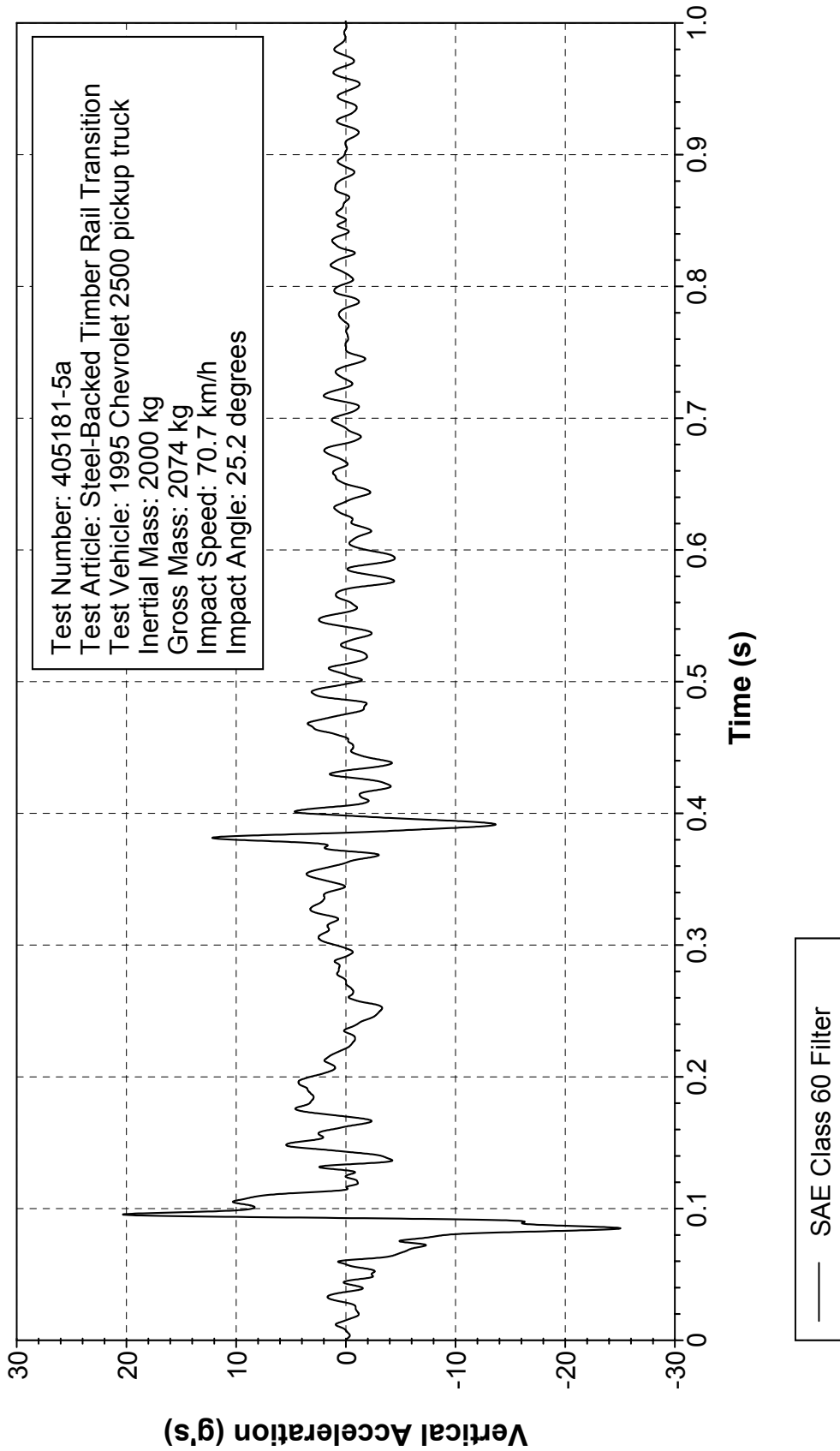

Figure 338. Vehicle vertical accelerometer trace for test 405181-5a (accelerometer located at center of gravity).

# X Acceleration over Rear Axle

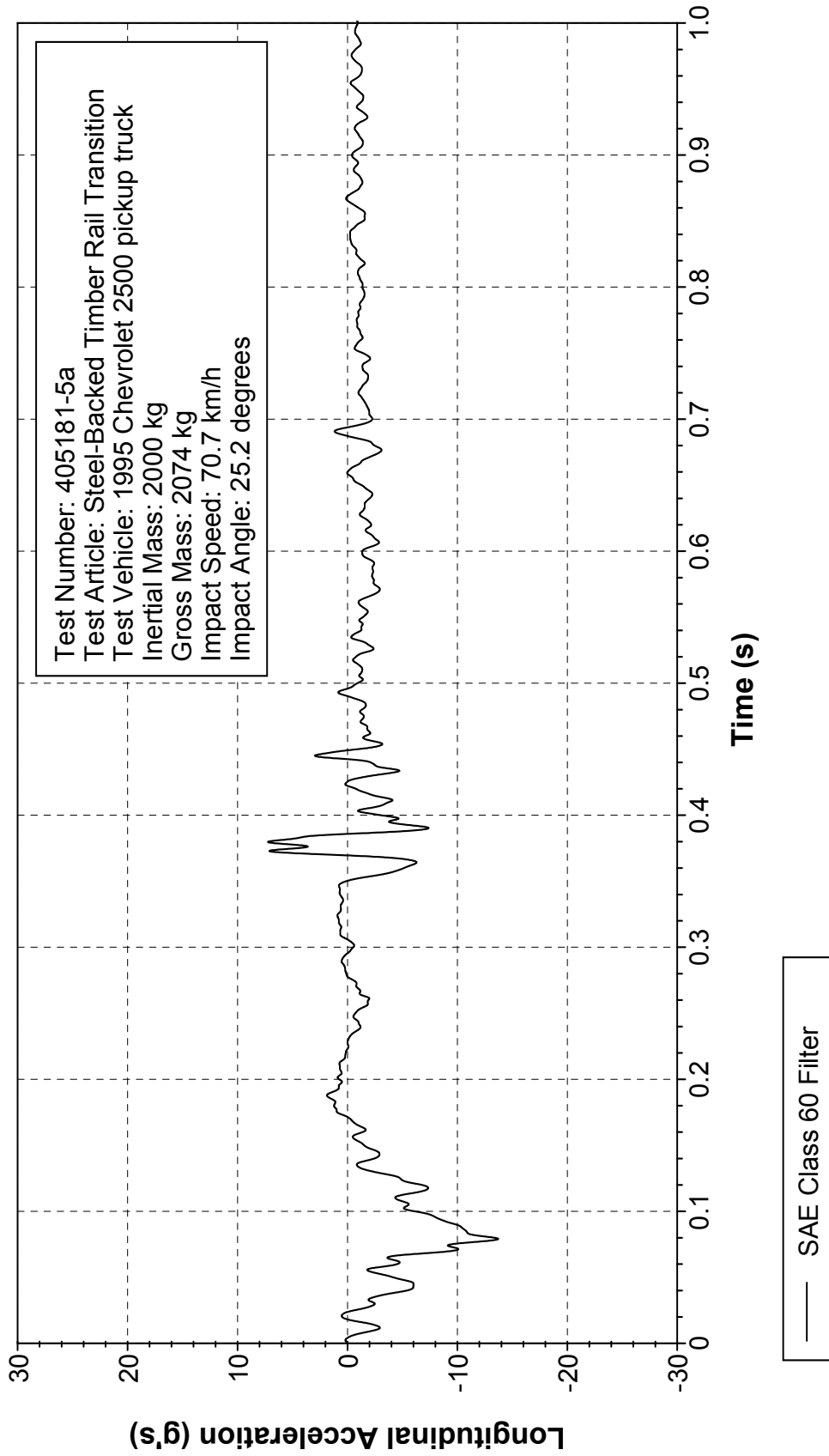

Figure 339. Vehicle longitudinal accelerometer trace for test 405181-5a  
(accelerometer located over rear axle).

# Y Acceleration over Rear Axle

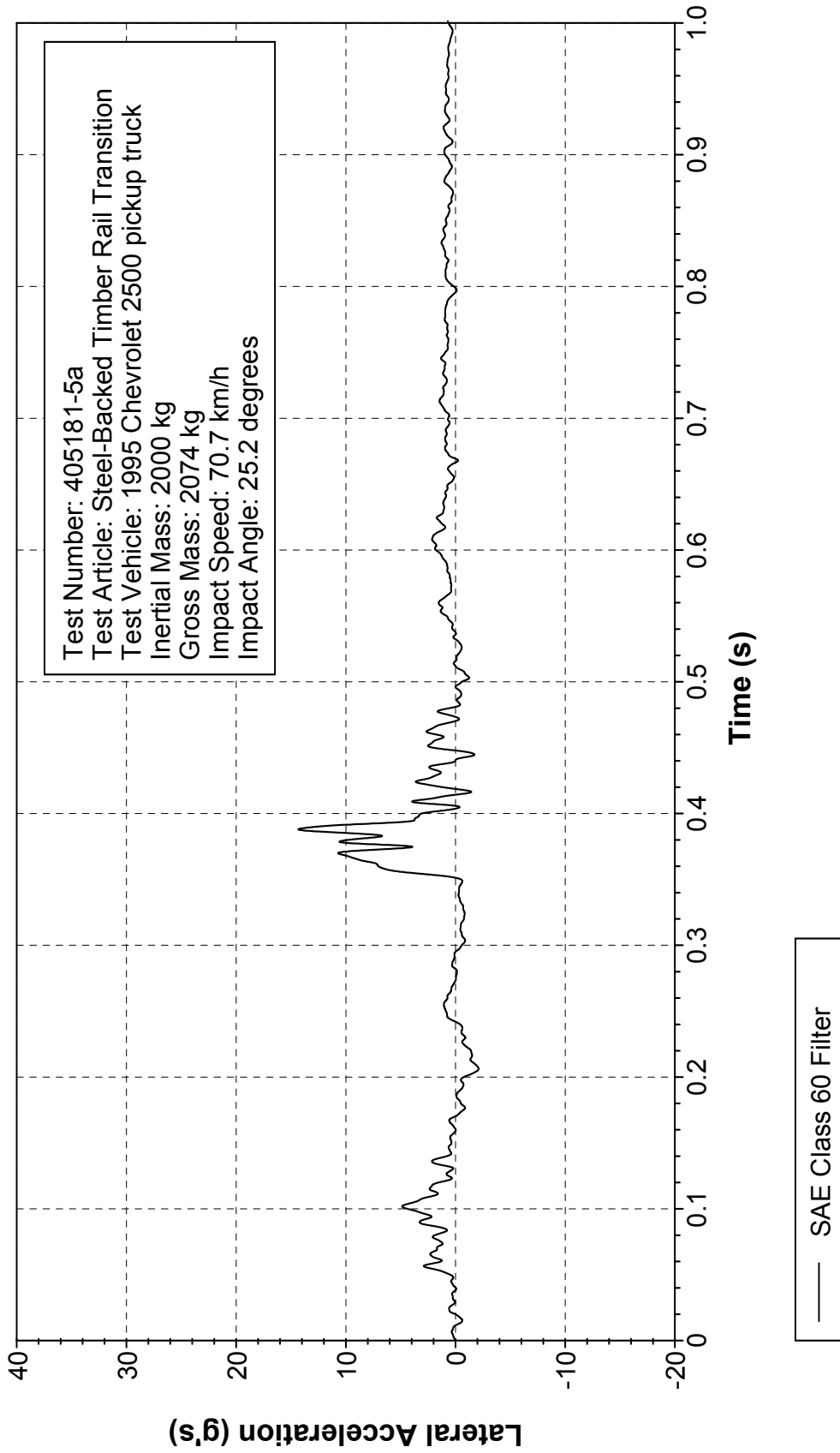

Figure 340. Vehicle lateral accelerometer trace for test 405181-5a (accelerometer located over rear axle).

# Z Acceleration over Rear Axle

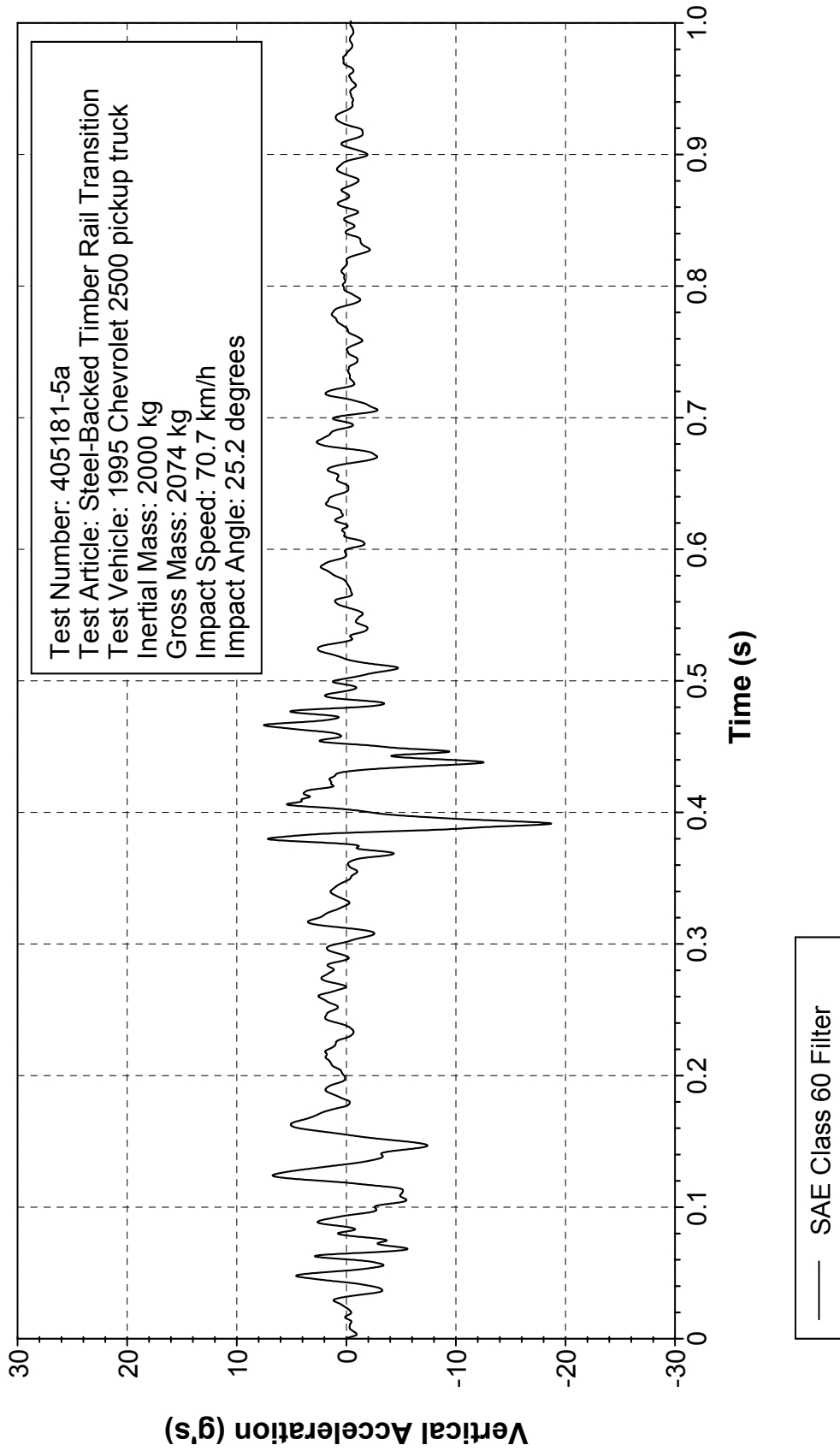

Figure 341. Vehicle vertical accelerometer trace for test 405181-5a (accelerometer located over rear axle).

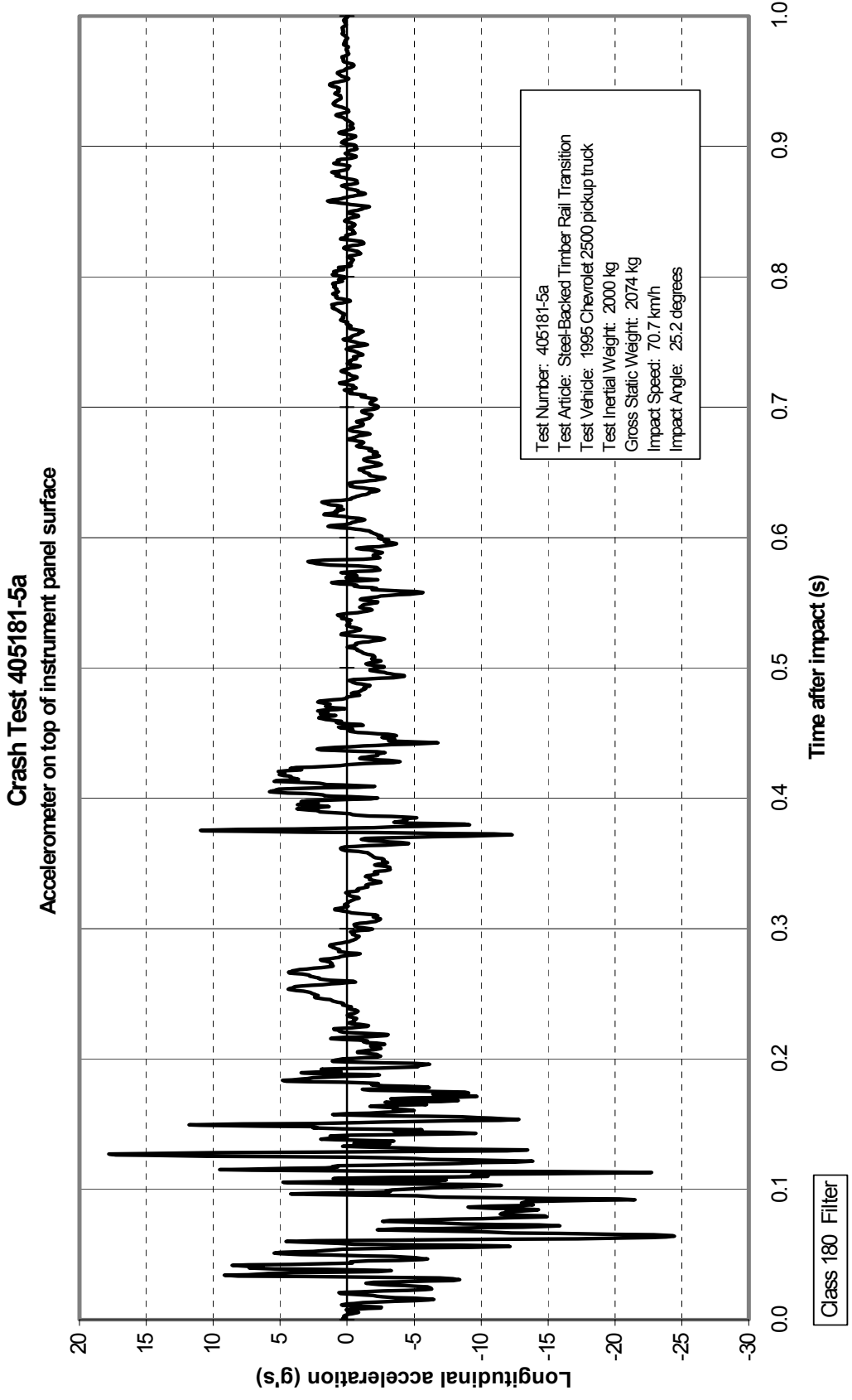

Figure 342. Vehicle longitudinal accelerometer trace for test 405181-5a (accelerometer located on top surface of instrument panel).

**Crash Test 405181-5a**  
Accelerometer on right front brake caliper

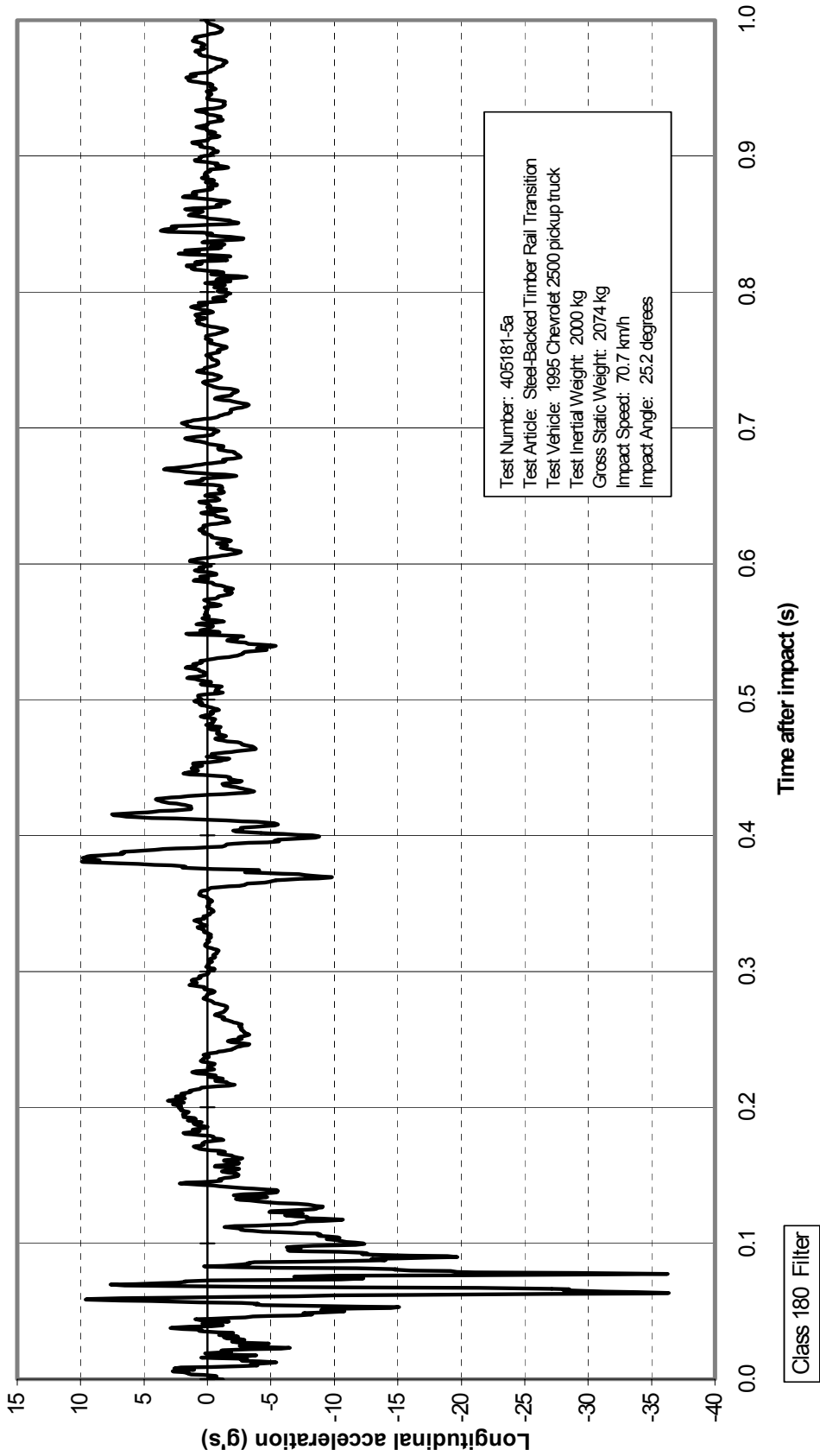

Figure 343. Vehicle longitudinal accelerometer trace for test 405181-5a (accelerometer located on right front brake caliper).

**Crash Test 405181-5a**  
Accelerometer on left front brake caliper

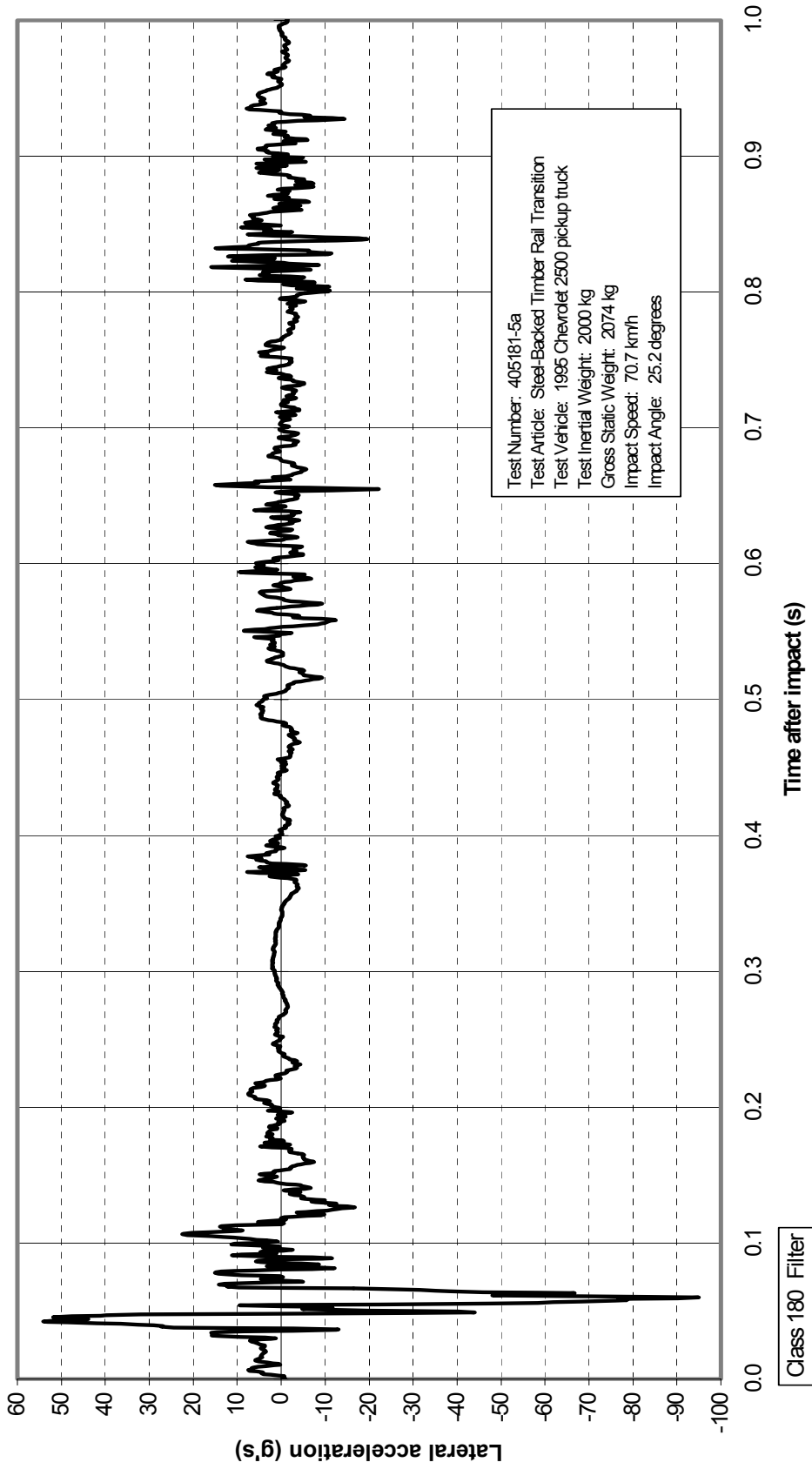

Figure 344. Vehicle longitudinal accelerometer trace for test 405181-5a (accelerometer located on left front brake caliper).

**Crash Test 405181-5a**  
Accelerometer on top of engine block

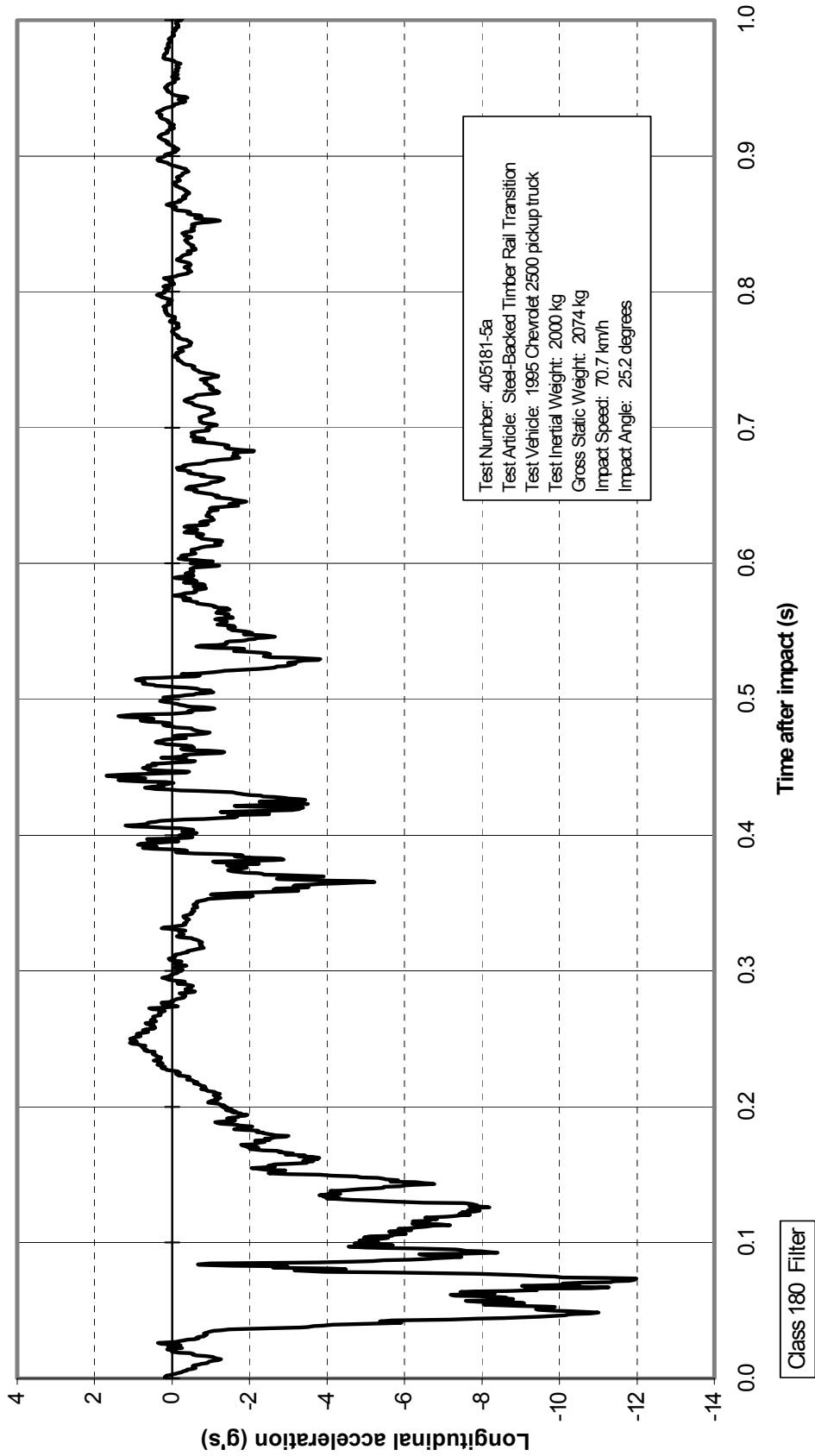

Figure 345. Vehicle longitudinal accelerometer trace for test 405181-5a (accelerometer located on top of engine block).



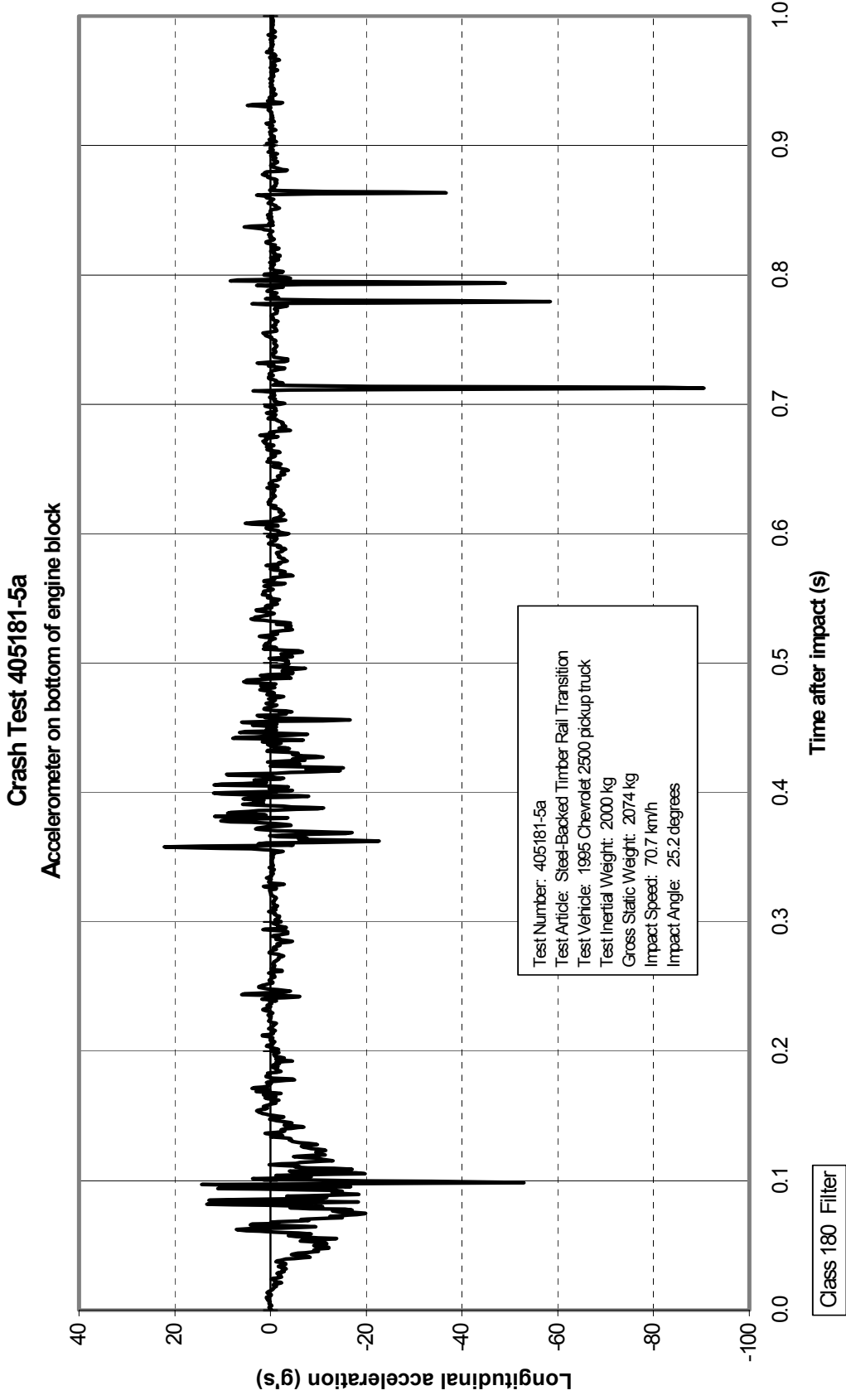

Figure 346. Vehicle longitudinal accelerometer trace for test 405181-5a (accelerometer located on bottom of engine block).

# Roll, Pitch, and Yaw Angles

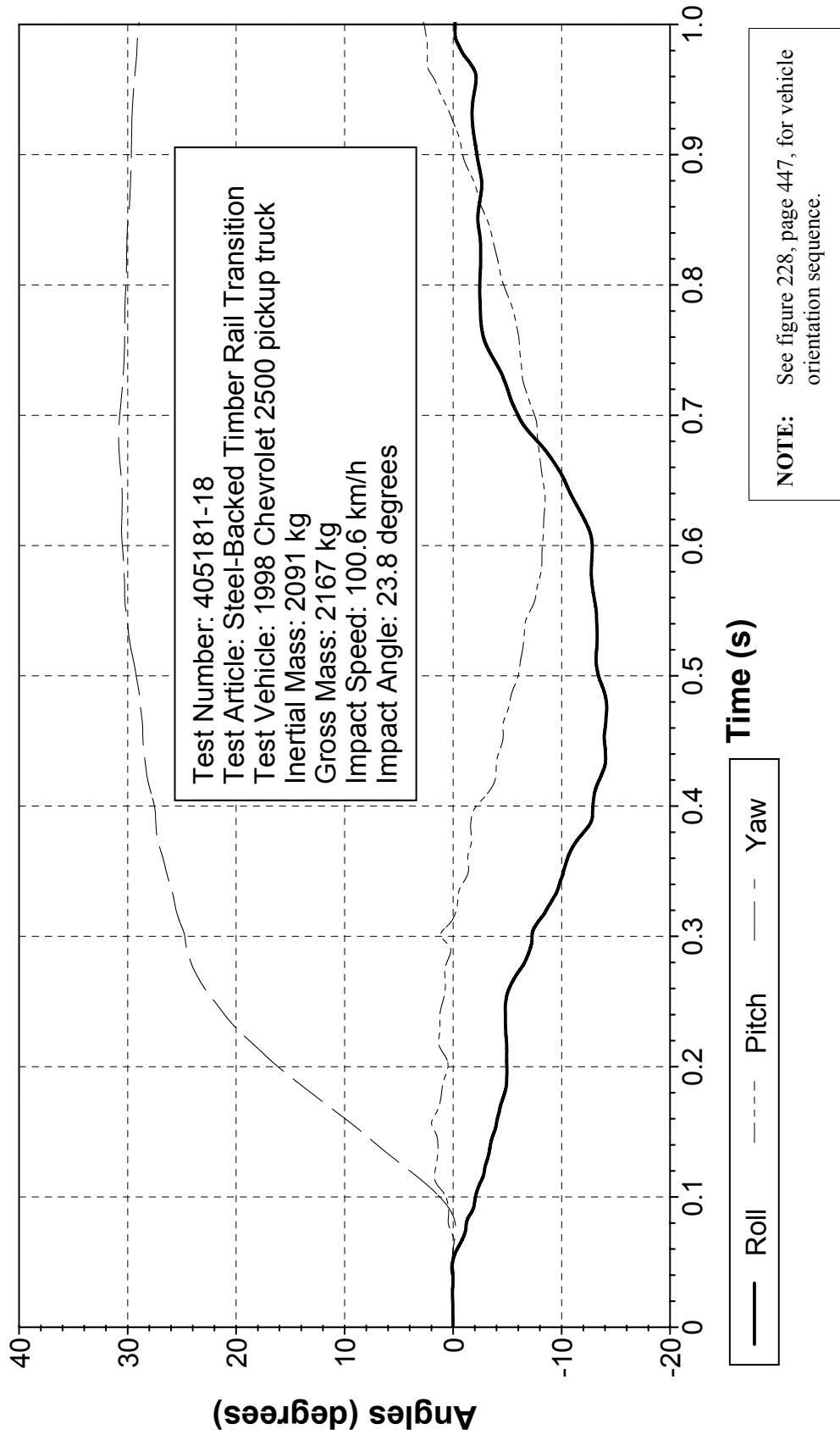

Figure 347. Vehicle angular displacements for test 405181-18.

# X Acceleration at C.G.

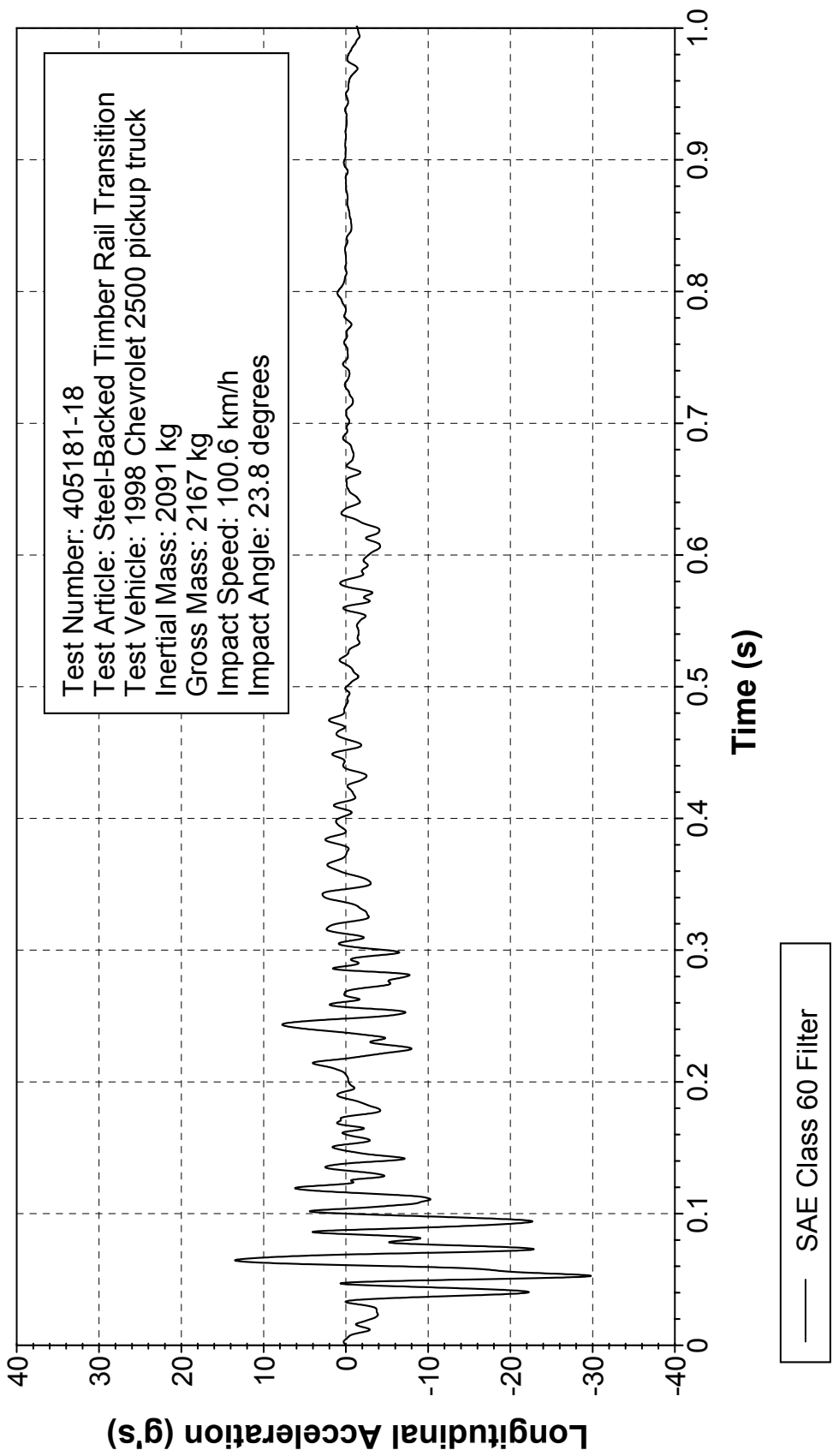

Figure 348. Vehicle longitudinal accelerometer trace for test 405181-18 (accelerometer located at center of gravity).

# Y Acceleration at C.G.

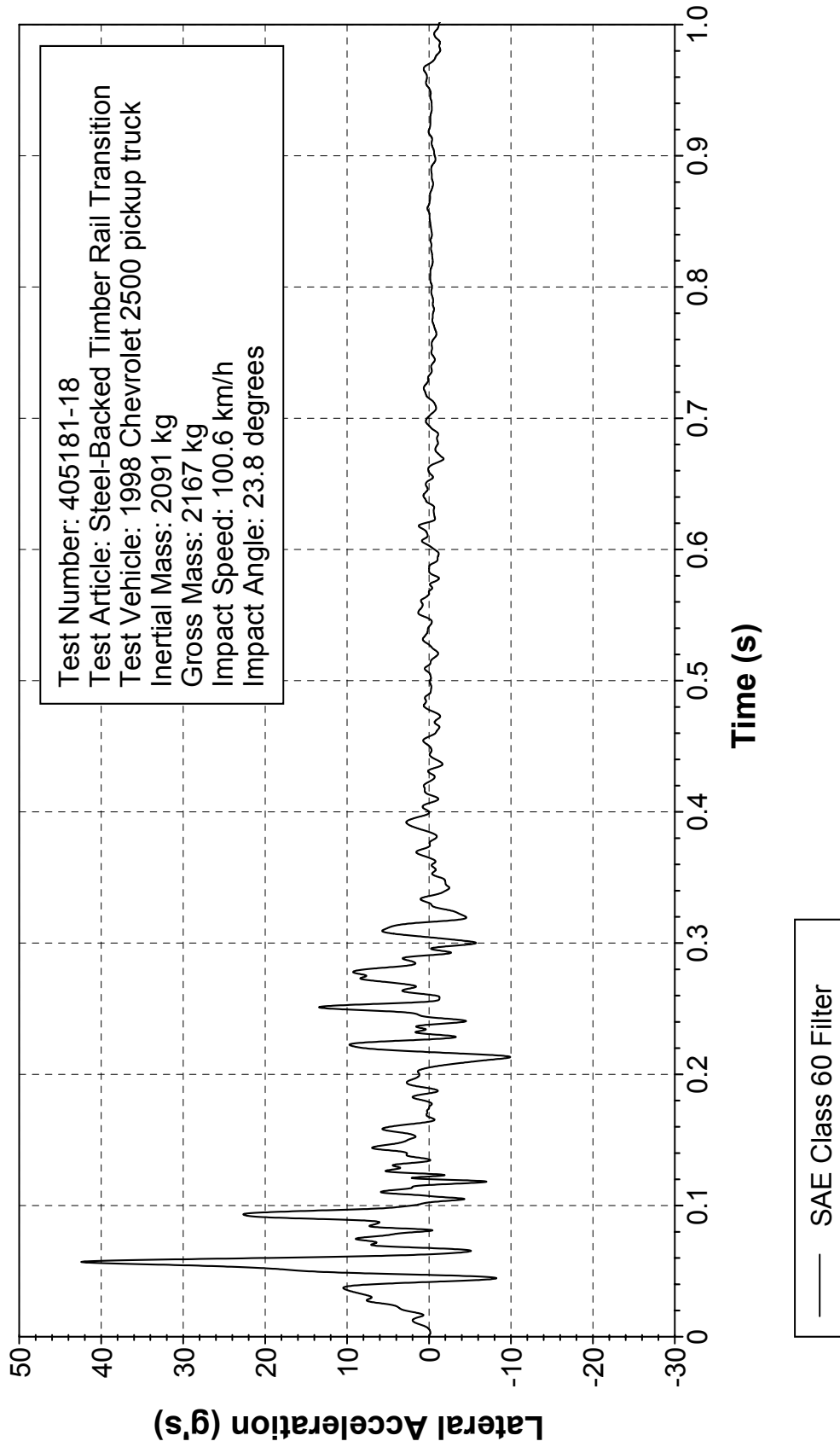

Figure 349. Vehicle lateral accelerometer trace for test 405181-18 (accelerometer located at center of gravity).

# Z Acceleration at C.G.

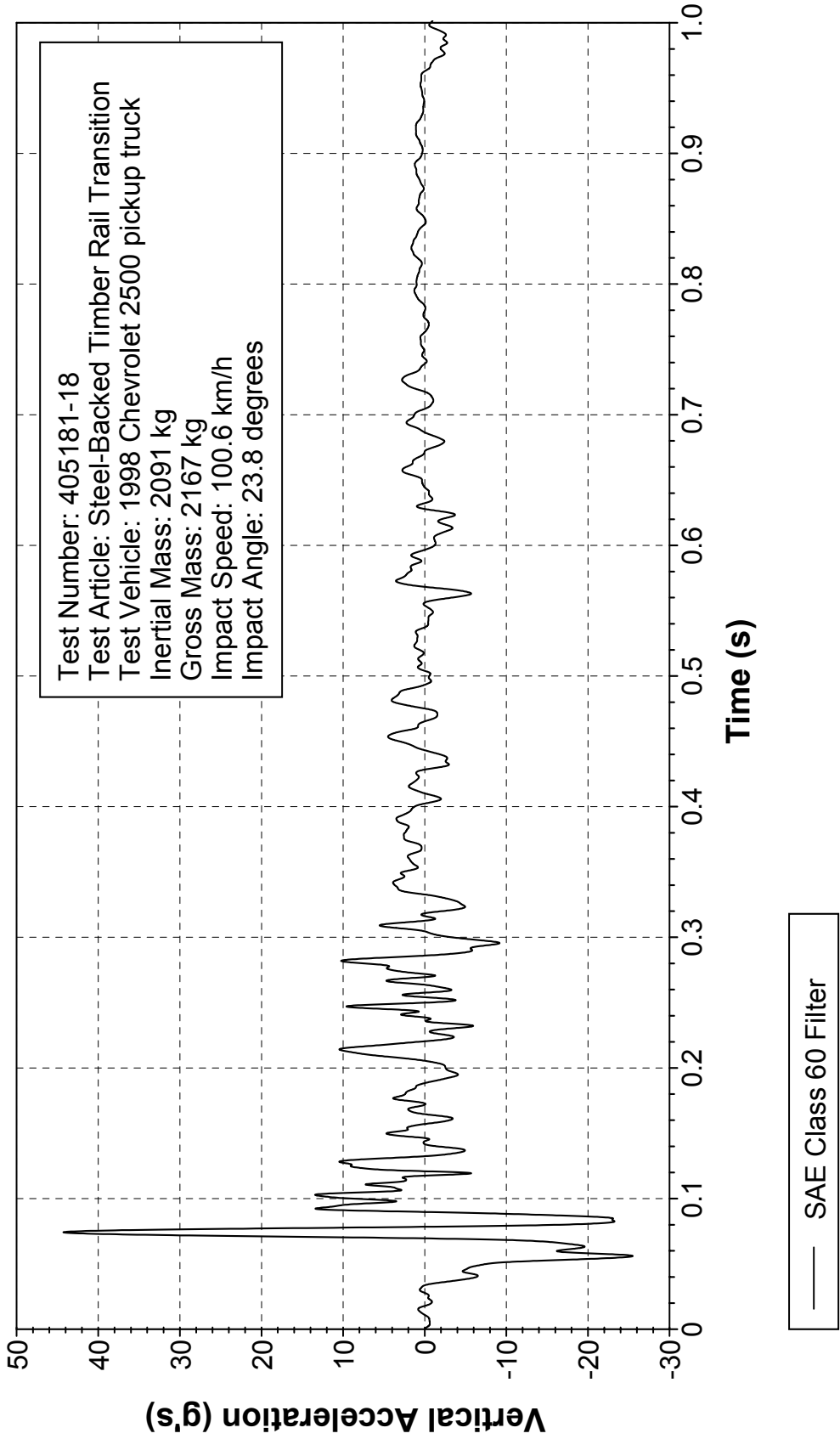

Figure 350. Vehicle vertical accelerometer trace for test 405181-18 (accelerometer located at center of gravity).

# X Acceleration over Rear Axle

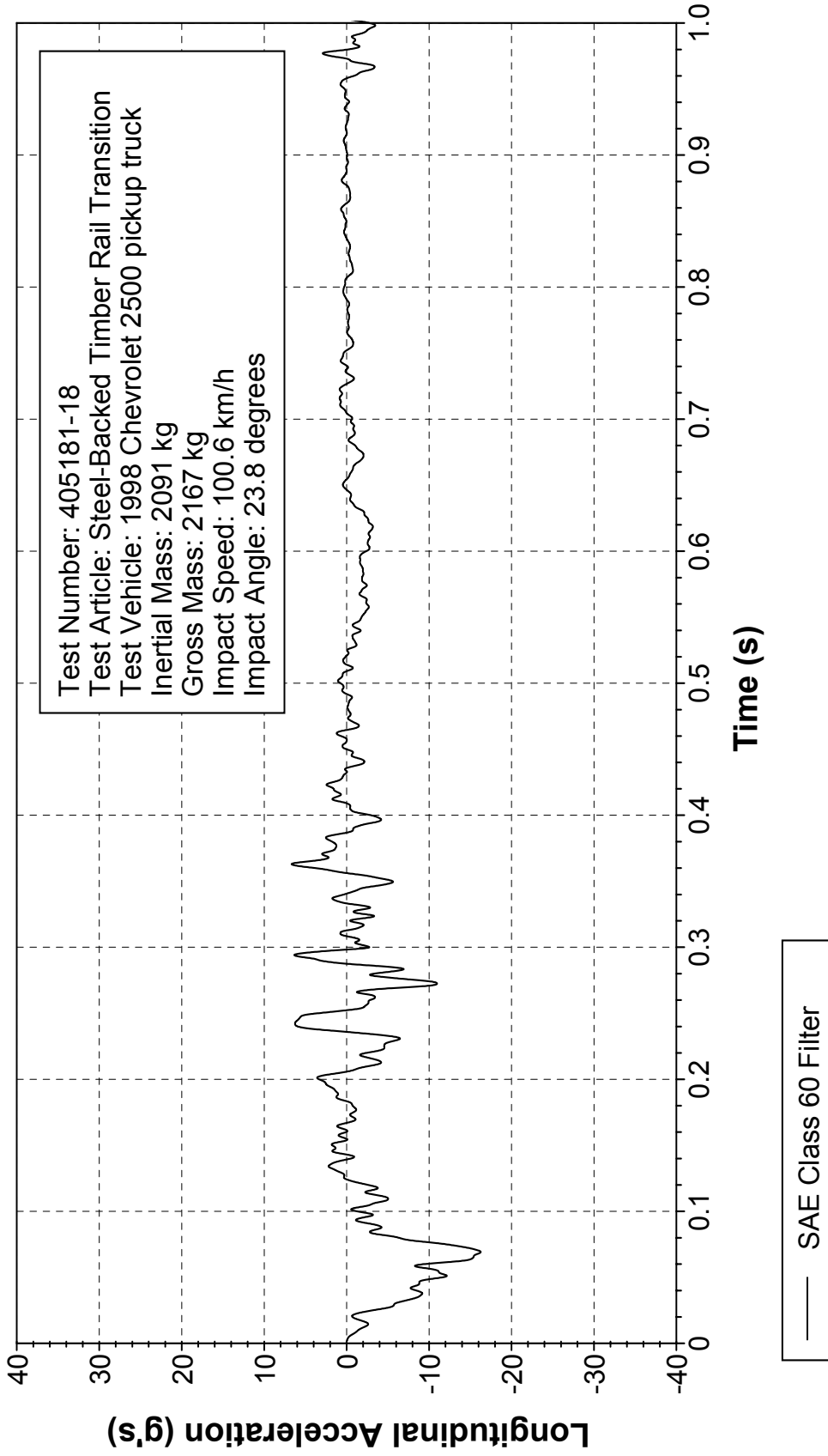

Figure 351. Vehicle longitudinal accelerometer trace for test 405181-18 (accelerometer located over rear axle).

# Y Acceleration over Rear Axle

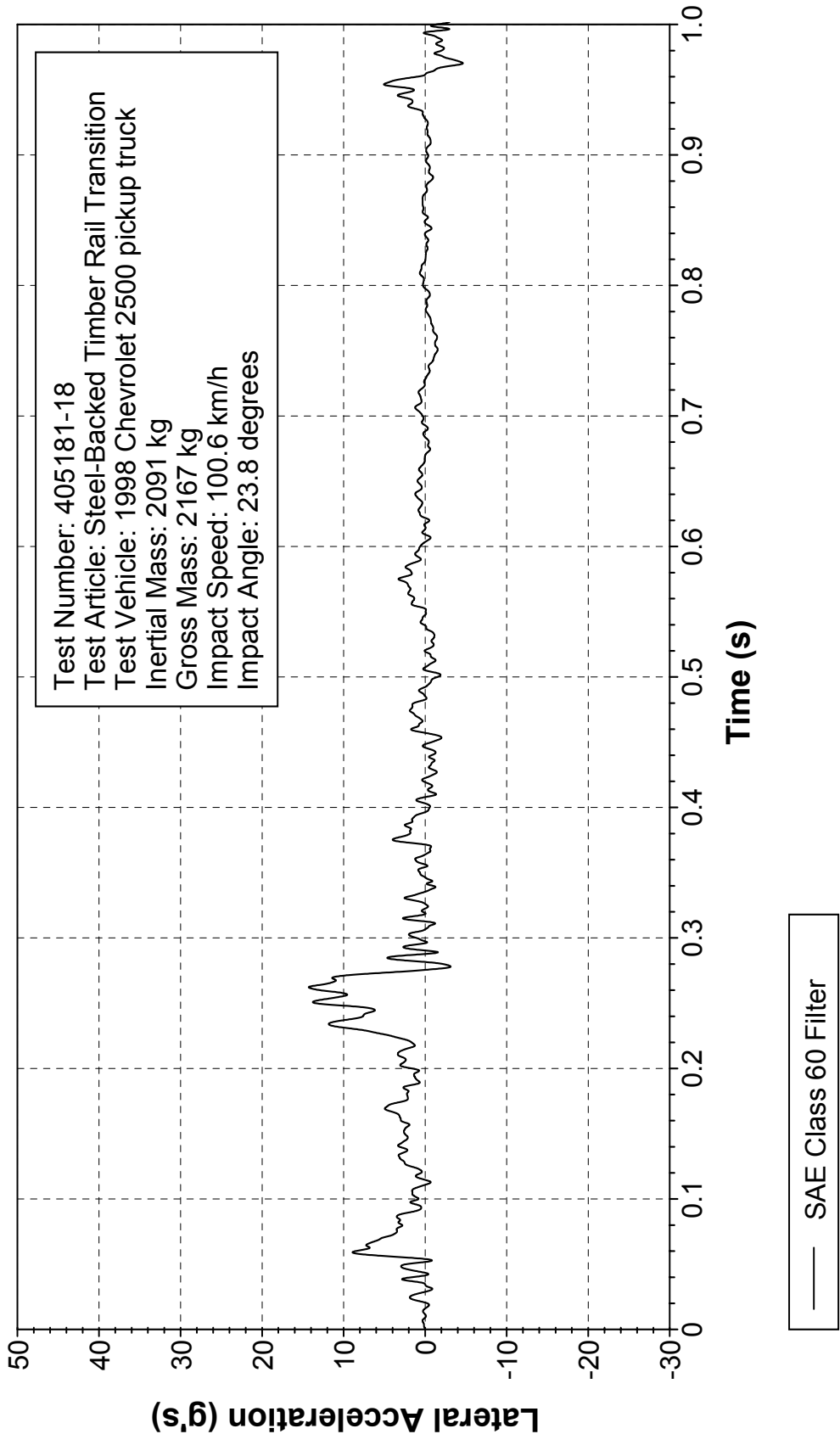

Figure 352. Vehicle lateral accelerometer trace for test 405181-18 (accelerometer located over rear axle).

# Z Acceleration over Rear Axle

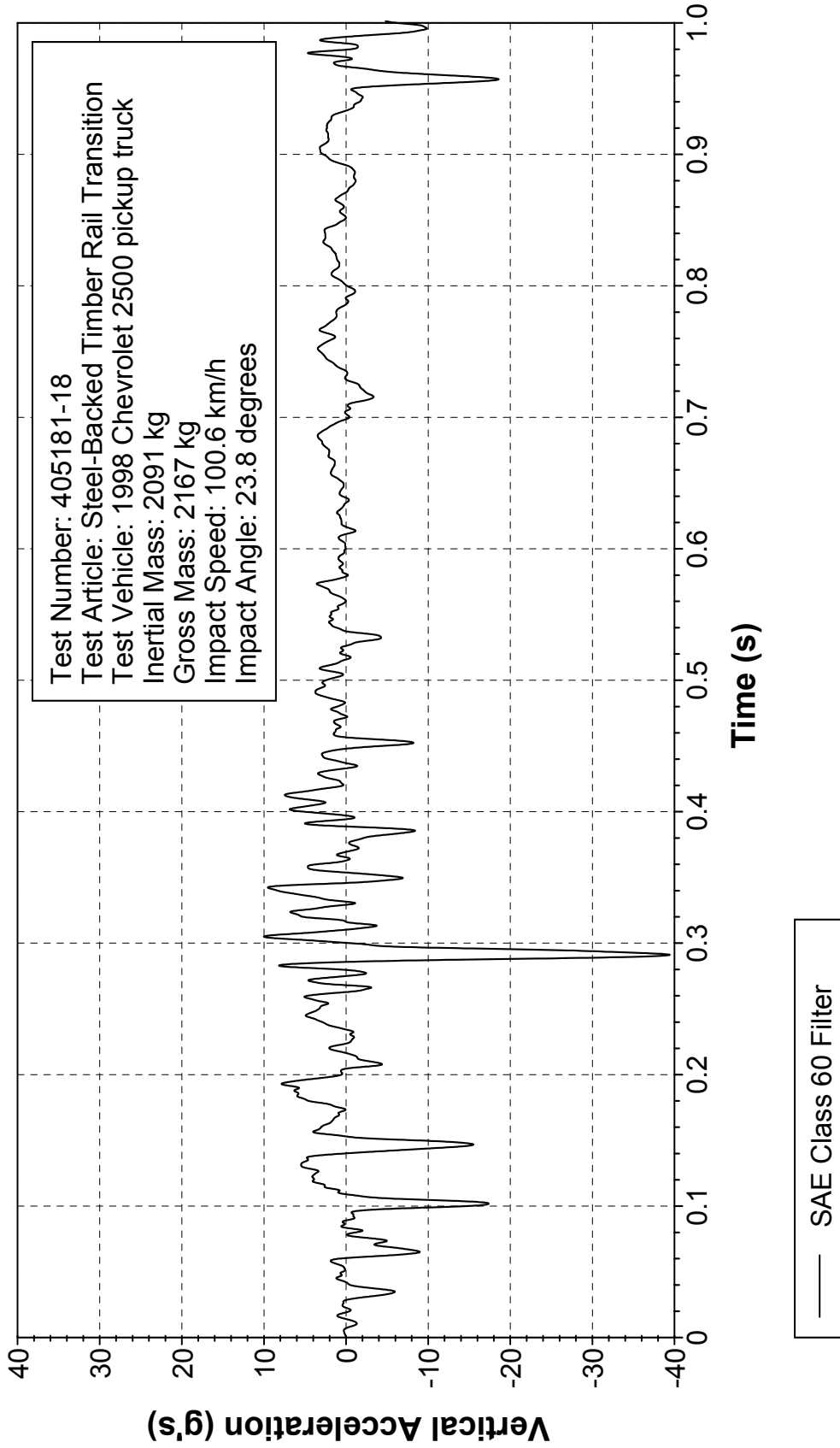

Figure 353. Vehicle vertical accelerometer trace for test 405181-18 (accelerometer located over rear axle).



# Roll, Pitch, and Yaw Angles

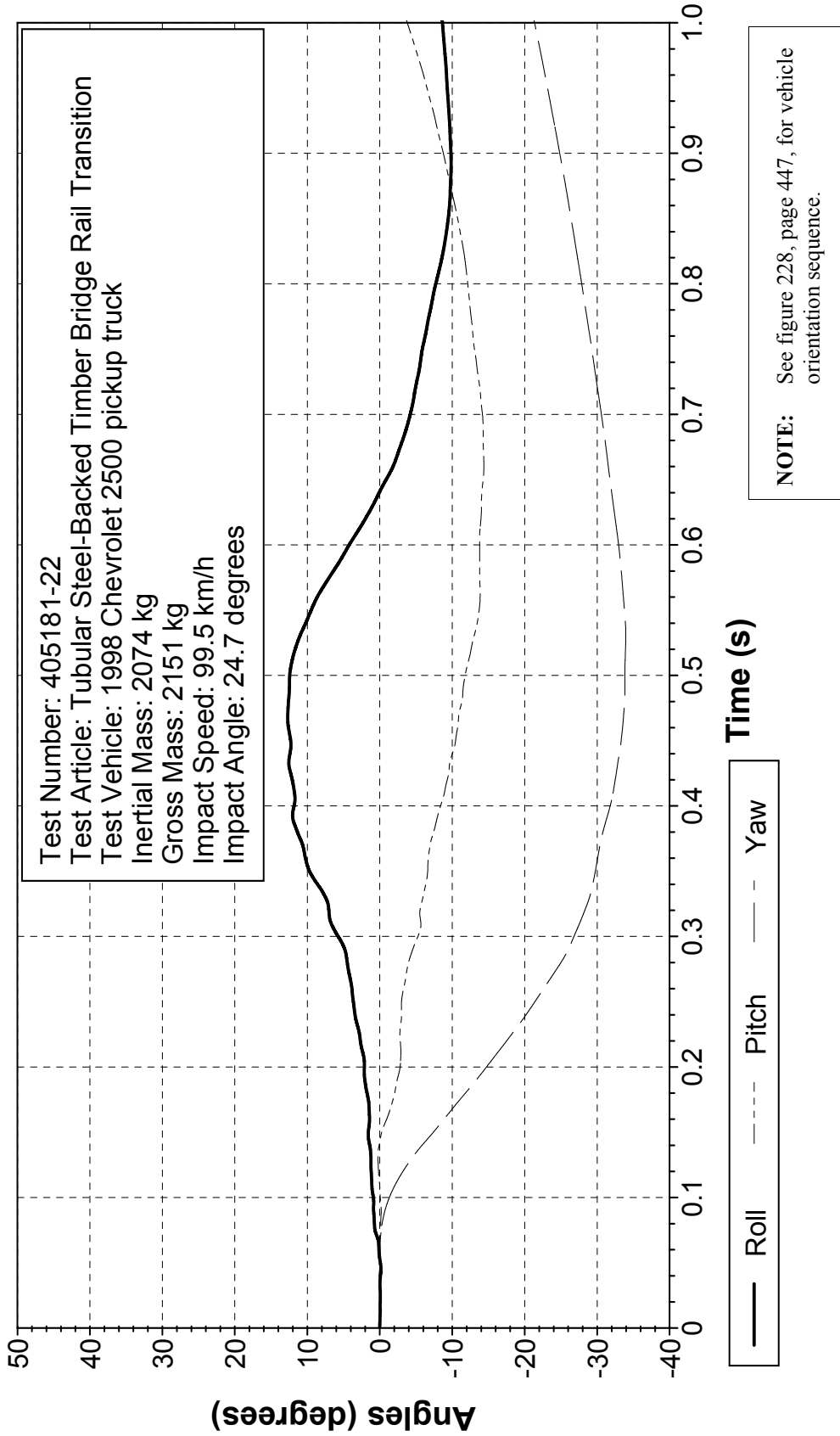

Figure 354. Vehicle angular displacements for test 405181-22.

# X Acceleration at C.G.

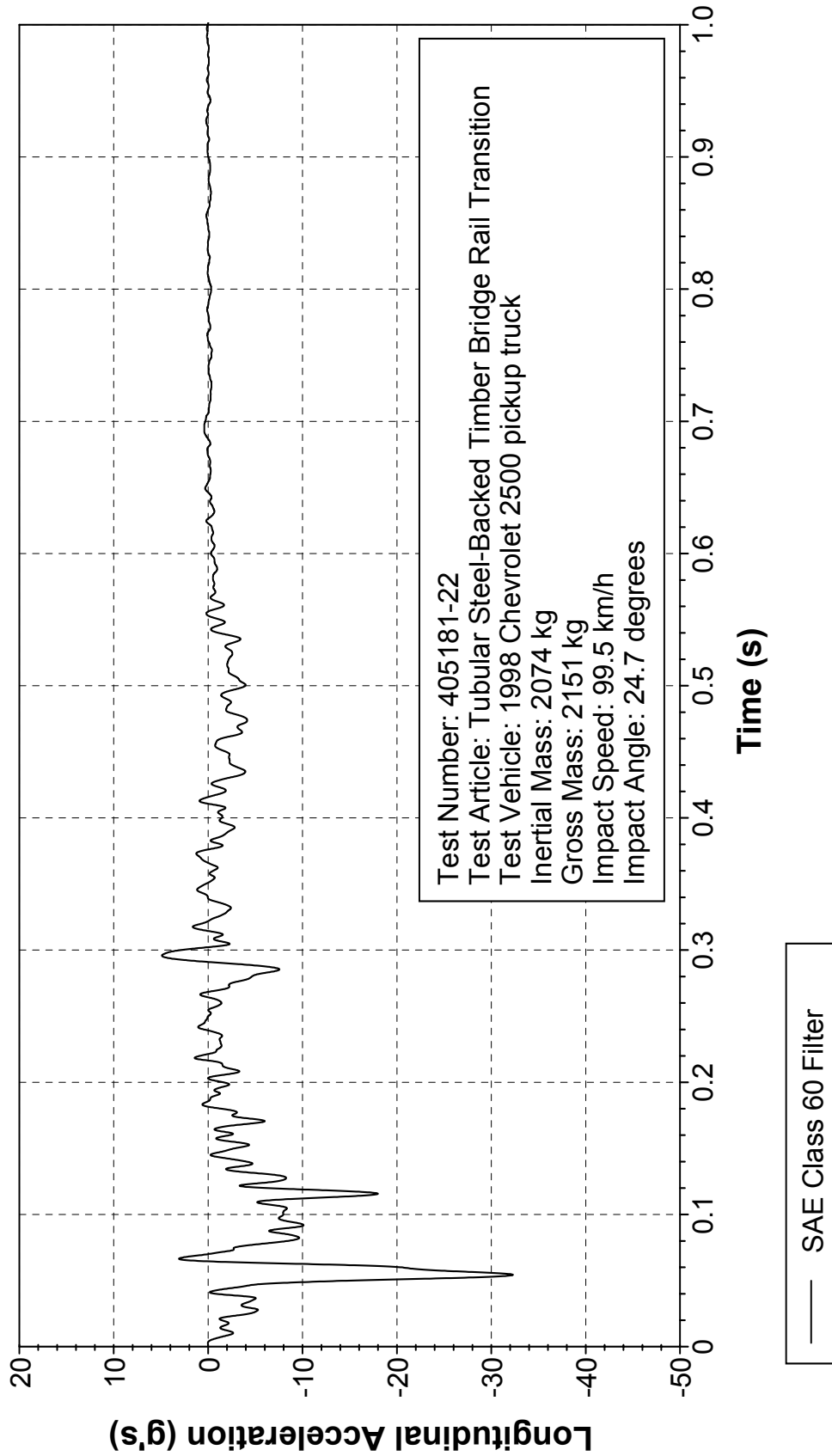

Figure 355. Vehicle longitudinal accelerometer trace for test 405181-22 (accelerometer located at center of gravity).

# Y Acceleration at C.G.

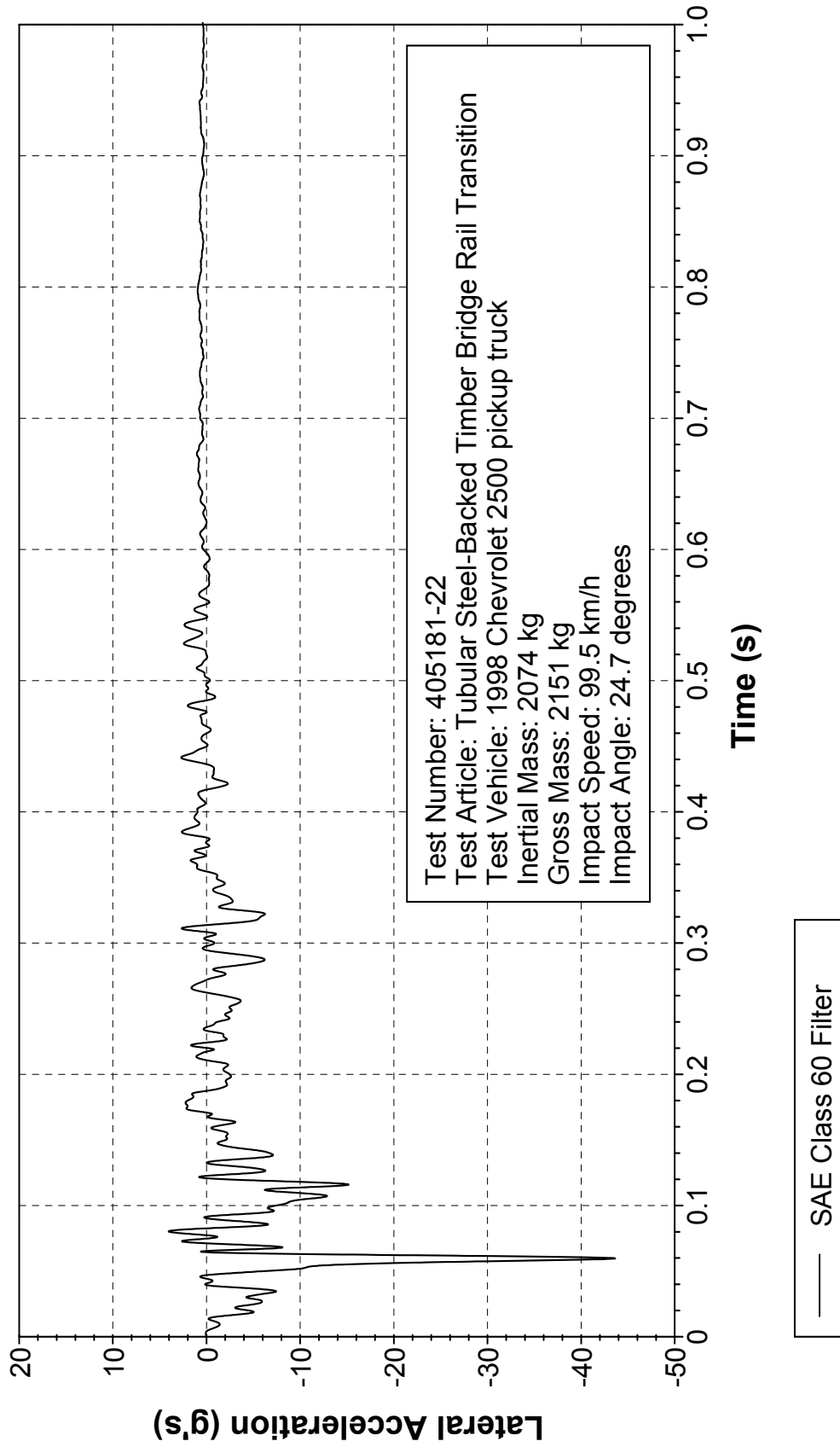

Figure 356. Vehicle lateral accelerometer trace for test 405181-22 (accelerometer located at center of gravity).

# Z Acceleration at C.G.

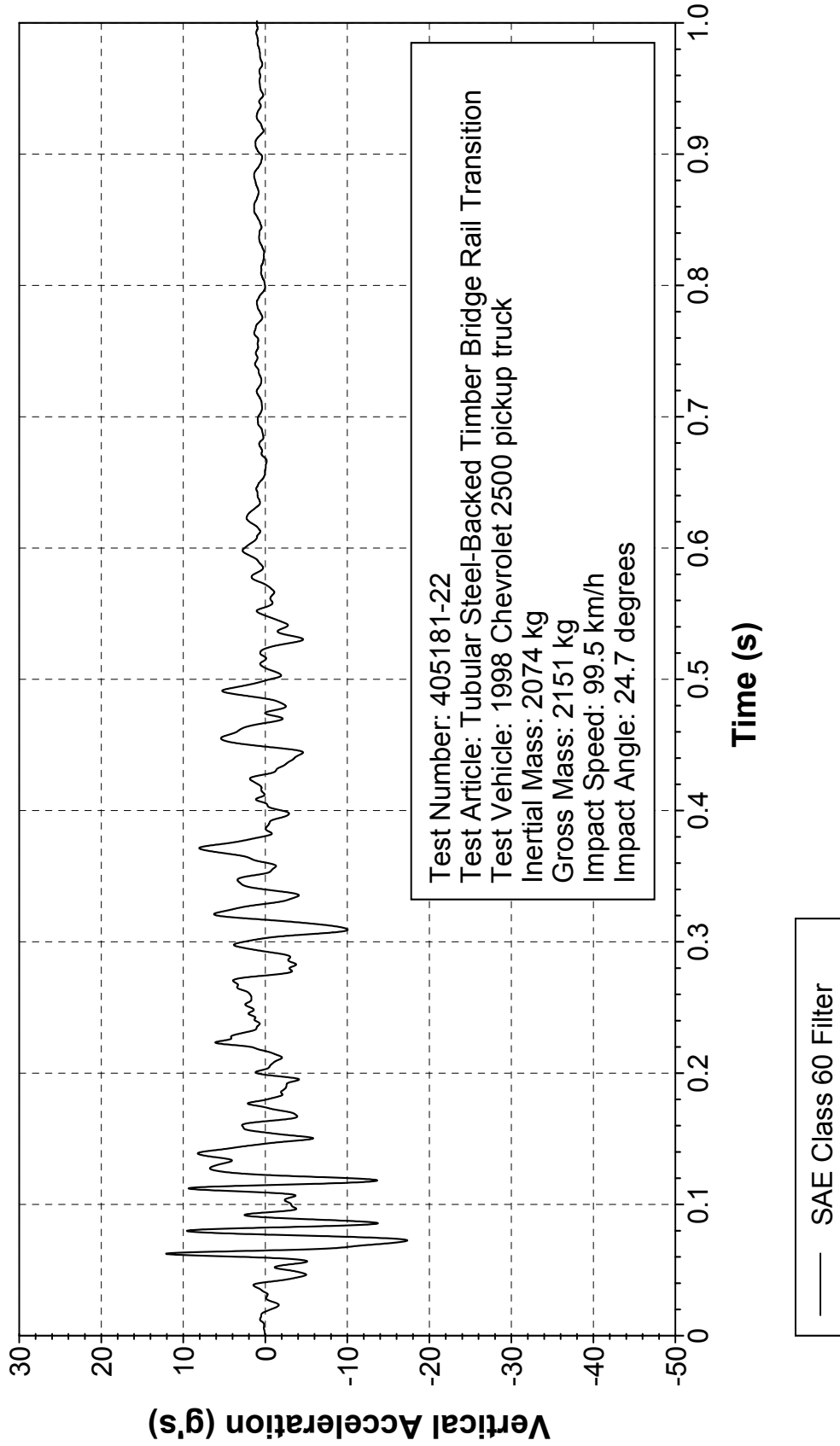

Figure 357. Vehicle vertical accelerometer trace for test 405181-22 (accelerometer located at center of gravity).

# X Acceleration over Rear Axle

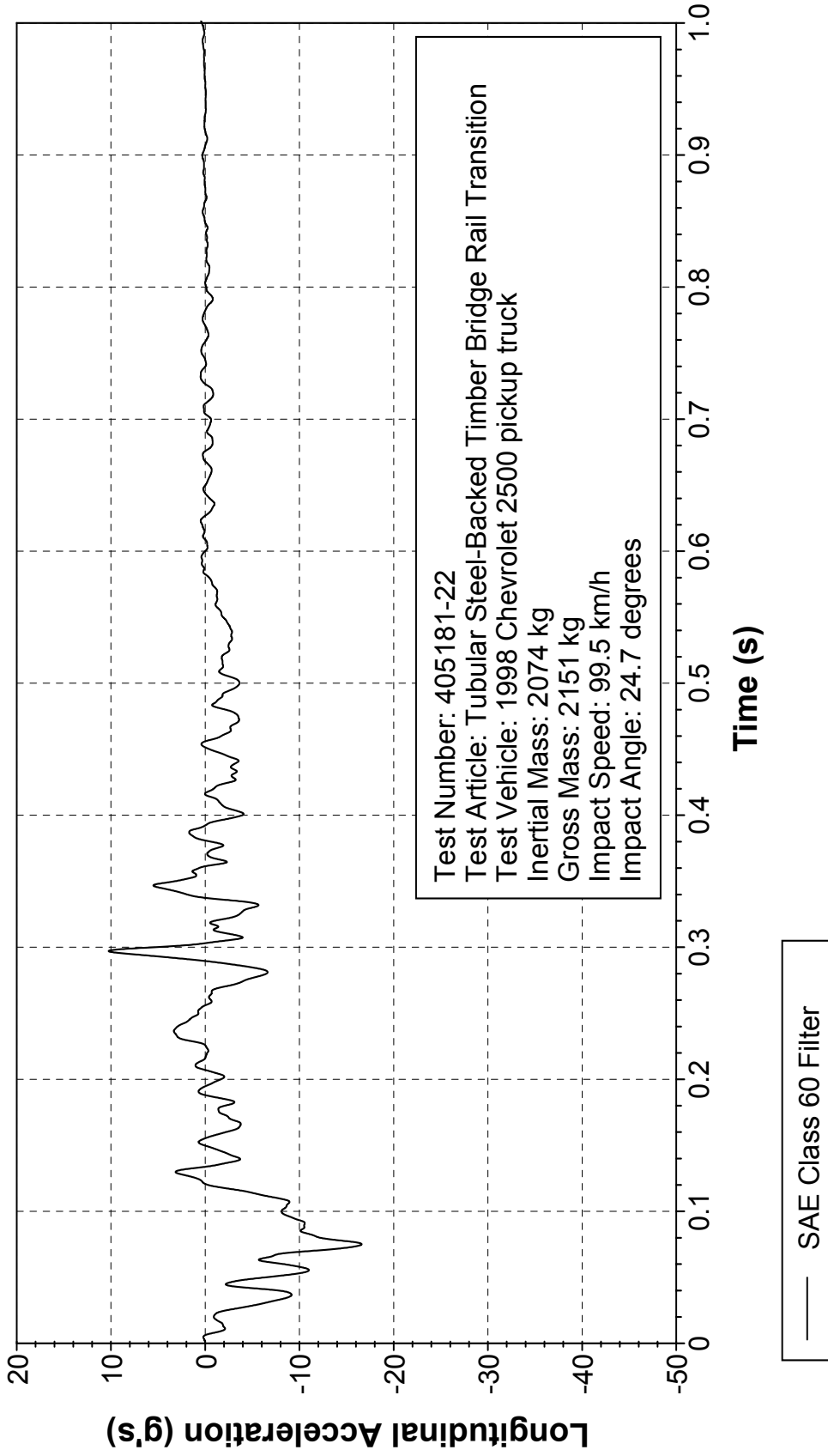

Figure 358. Vehicle longitudinal accelerometer trace for test 405181-22 (accelerometer located over rear axle).

# Y Acceleration over Rear Axle

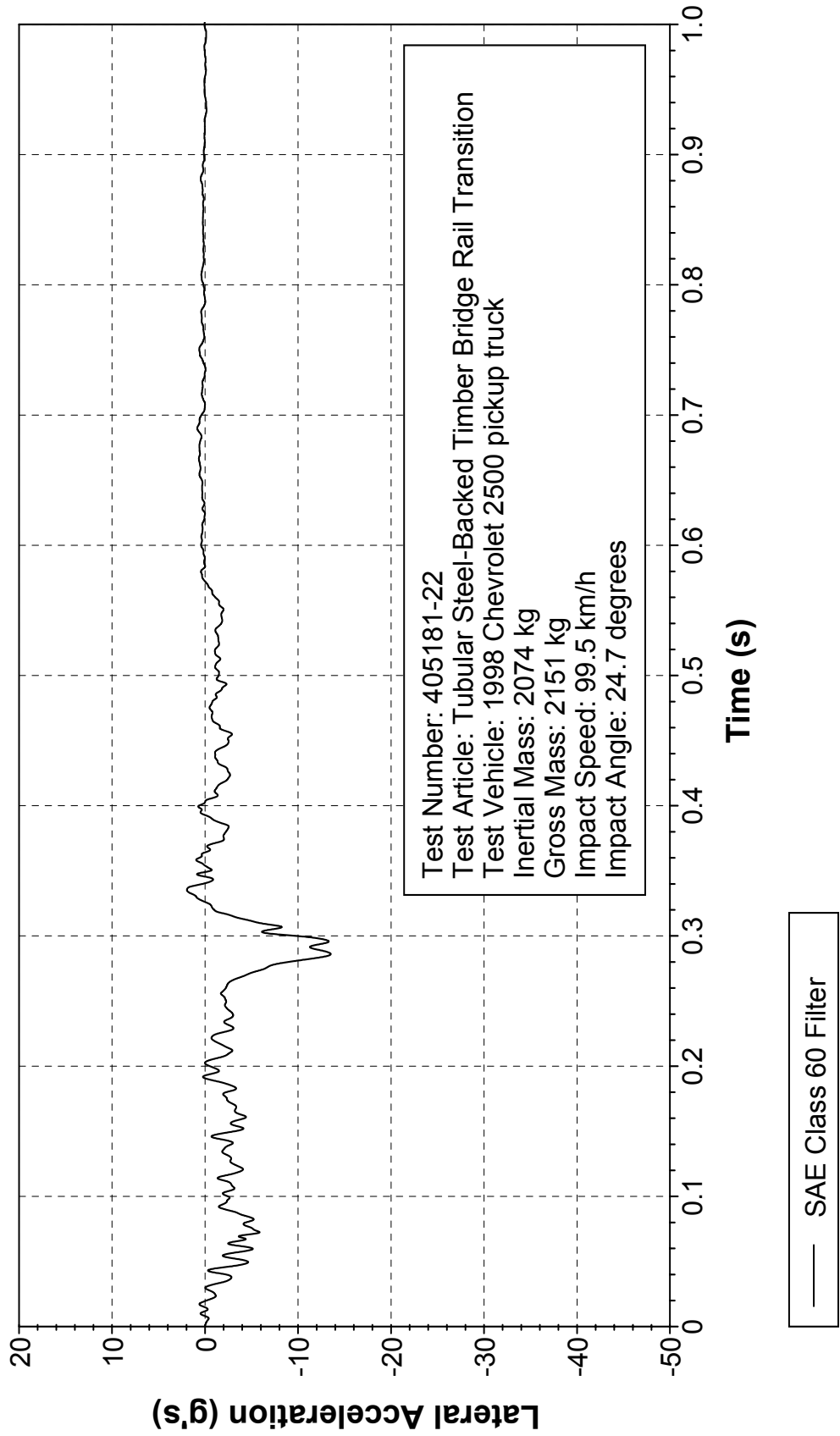

Figure 359. Vehicle lateral accelerometer trace for test 405181-22 (accelerometer located over rear axle).

# Z Acceleration over Rear Axle

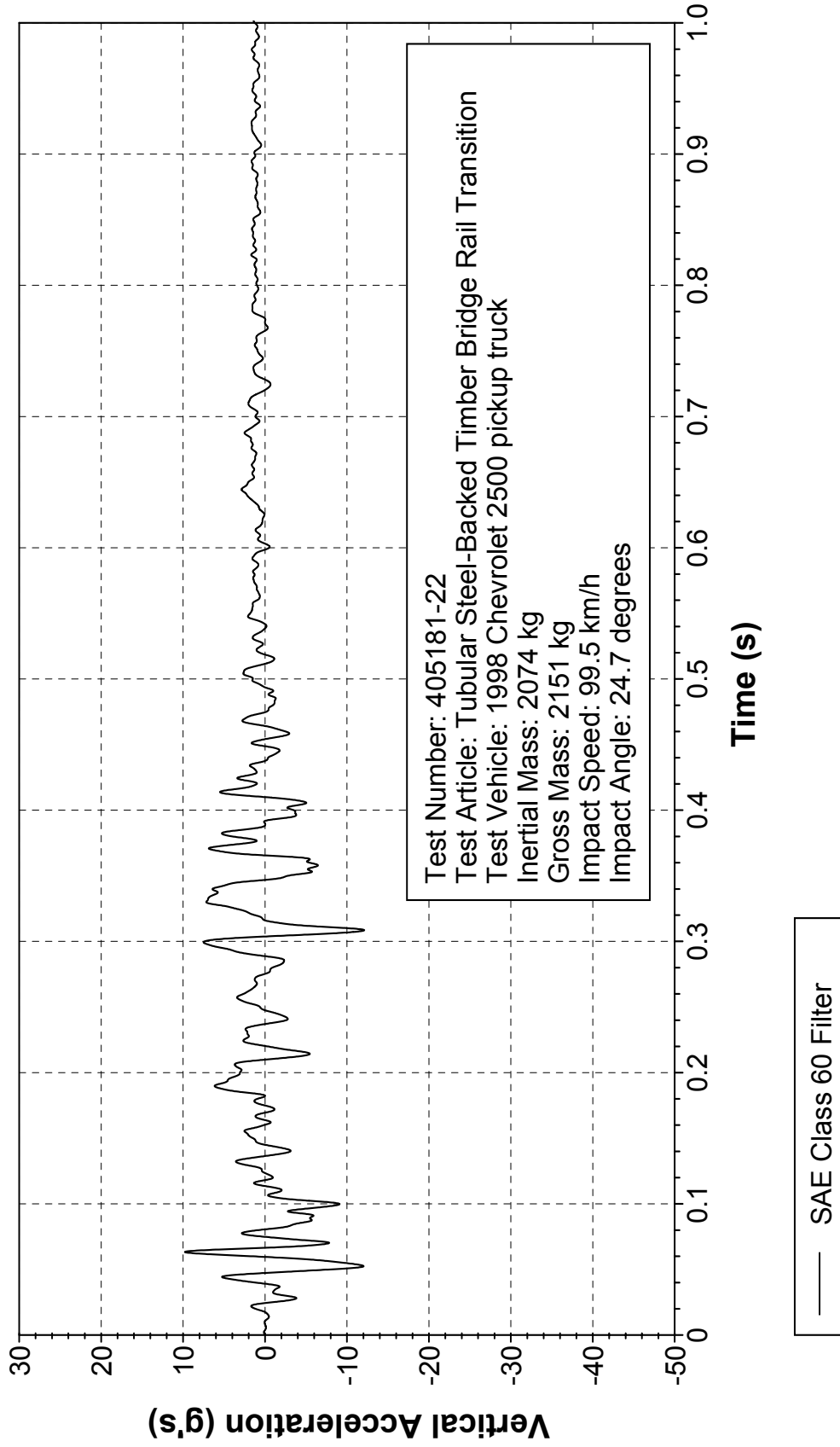

Figure 360. Vehicle vertical accelerometer trace for test 405181-22 (accelerometer located over rear axle).





## APPENDIX E. RAIL INSTRUMENTATION TRACES

Six strain gages and one accelerometer were installed on the steel-backed timber guardrail (crash test 405181-5a) to measure longitudinal strains in the steel rail and post acceleration during the crash test. Graphs of data from the strain gauges installed on the railing are provided in this appendix. These data were collected to provide information for use in computer simulation. The data serve no purpose in determining acceptability of performance of the transition.

Strain gage bridges were located as follows: 1) 5570 mm from the end of the parapet on the field side of the plate at 555 mm from ground level; 2) 2000 mm from the end of the parapet on the field side of the plate at 530 mm from ground level; 3) 1300 mm from the end of the parapet on the field side of the plate at 540 mm from ground level; 4) 960 mm from the end of the parapet on the field side of the plate at 540 mm from ground level; 5) 960 mm from the end of the parapet on the traffic side at 540 mm from ground level; 6) 70 mm from the end of the parapet on the field side of the plate at 550 mm from ground level. At these locations, the steel rail was prepared by first grinding away the mill scale to produce a clean and smooth surface in a 60 mm x 30 mm area where the gages were spot-welded to bond them to the steel.

# X Axis Post 19 Acceleration

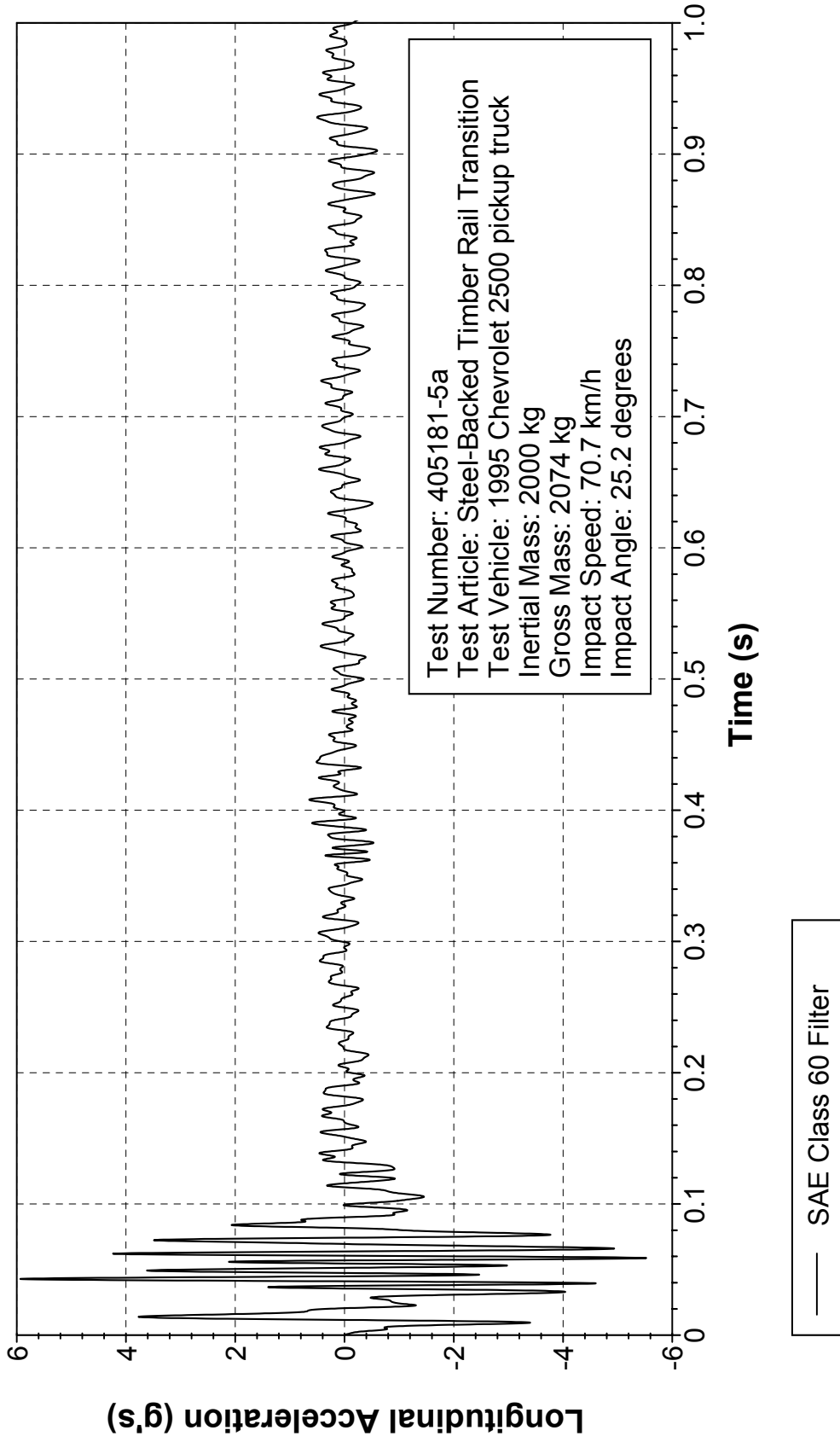

Figure 361. Longitudinal accelerometer trace for test 405181-5a (accelerometer located at center of post 19).

# Gage Location 1

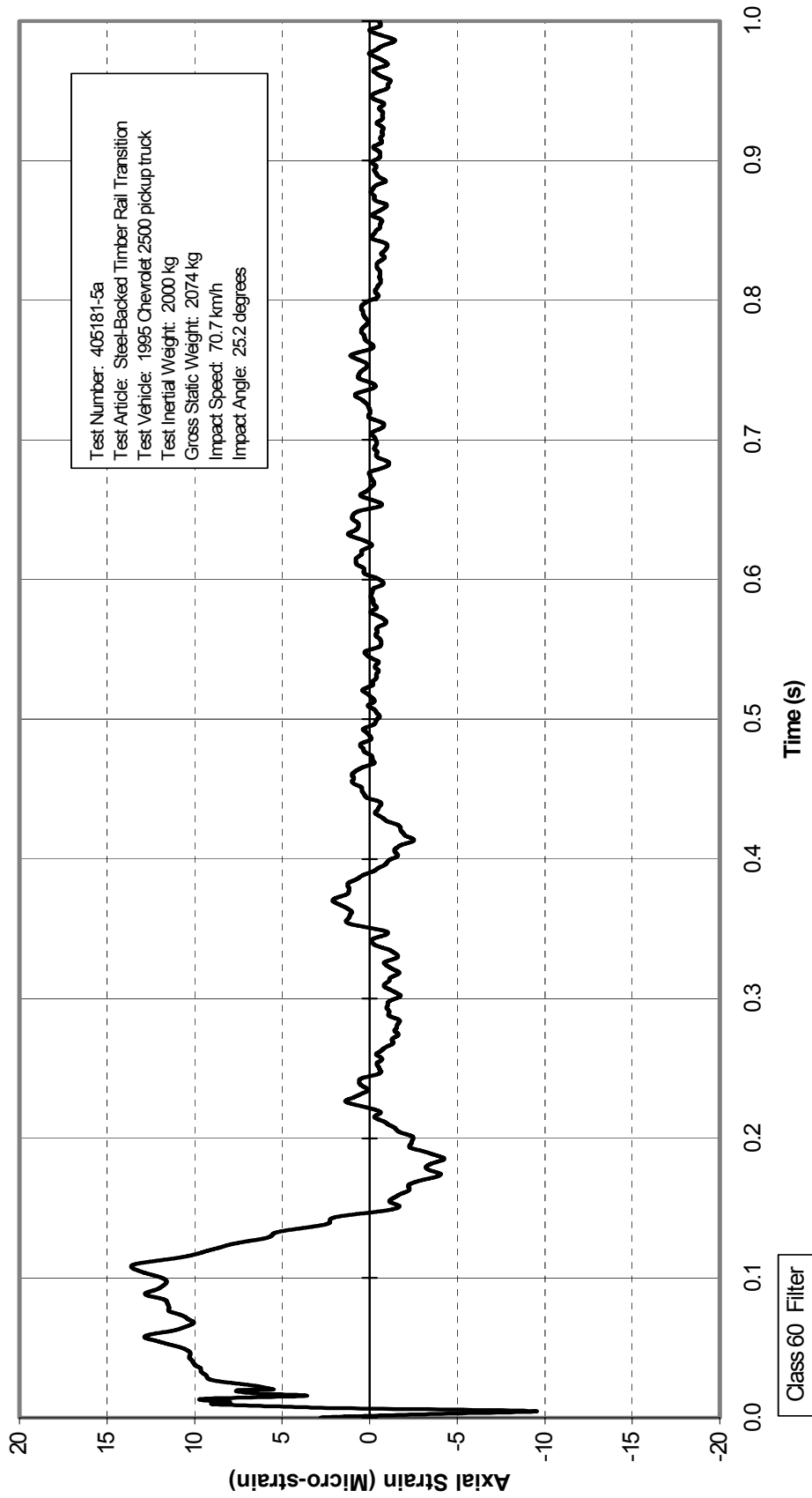

Figure 362. Axial strain, location 1, field side for test 405181-5a.

## Gage Location 2

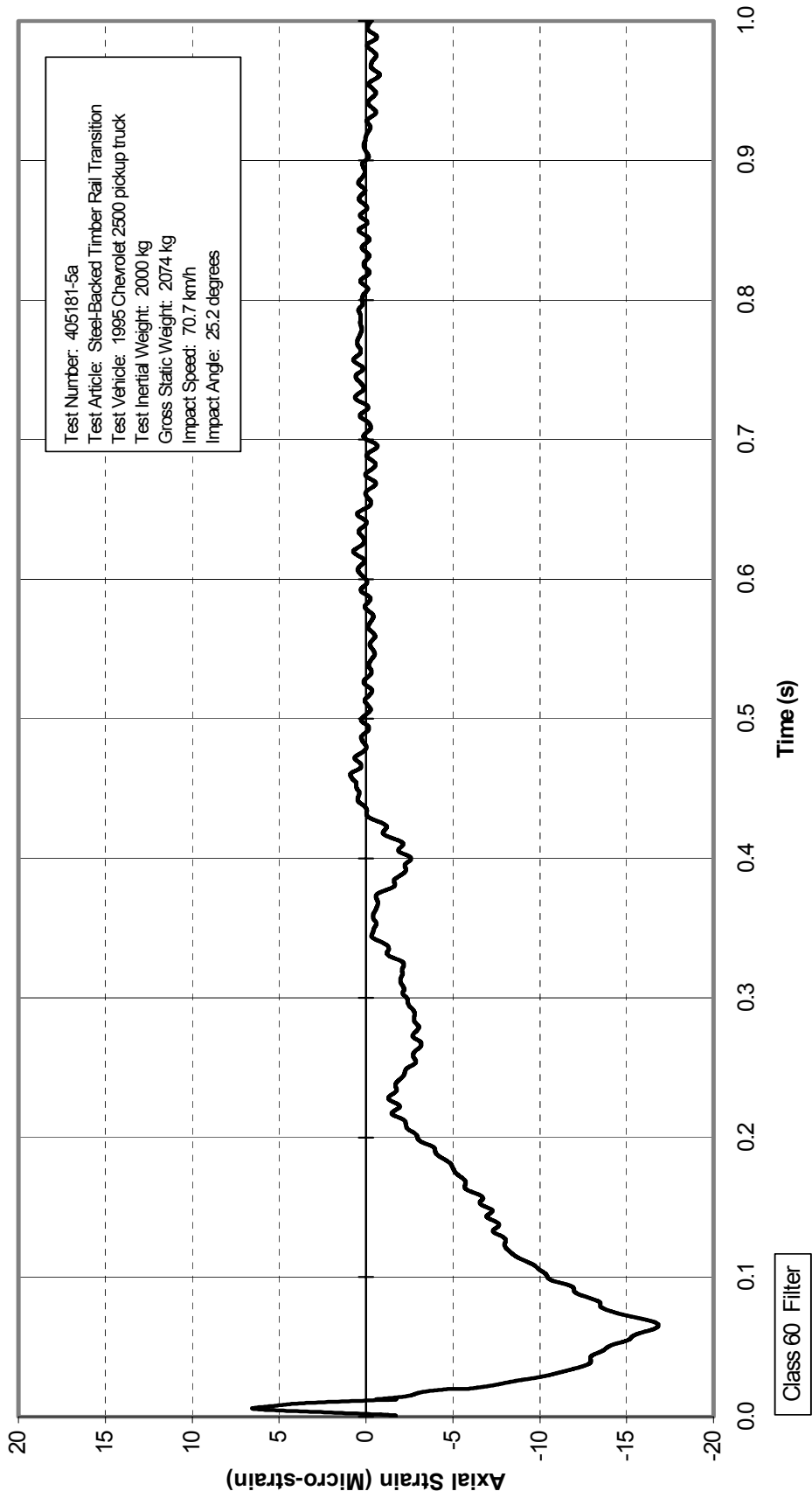

Figure 363. Axial strain, location 2, field side for test 405181-5a.

# Gage Location 3

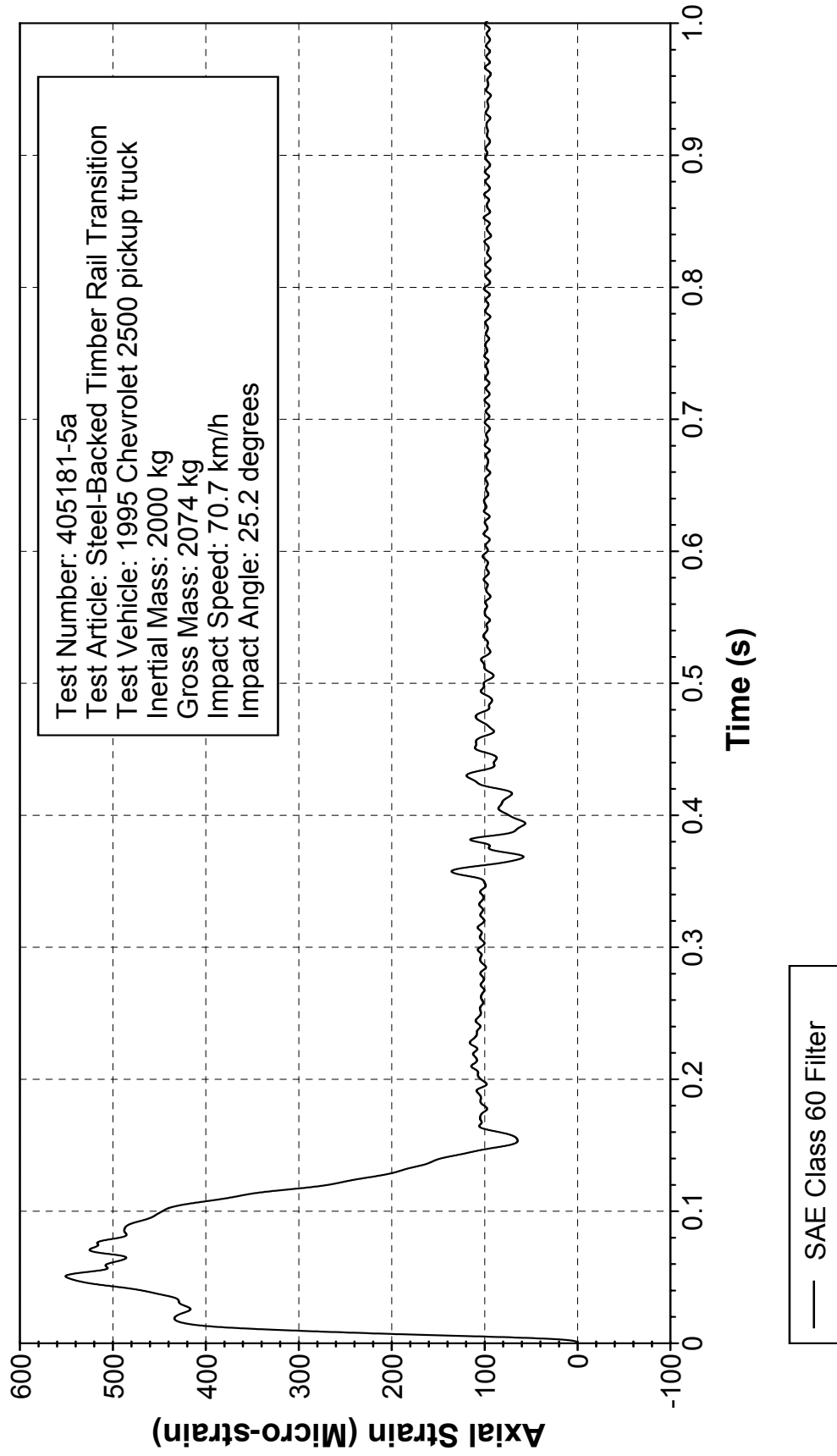

Figure 364. Axial strain, location 3, field side for test 405181-5a.

# Gage Location 4

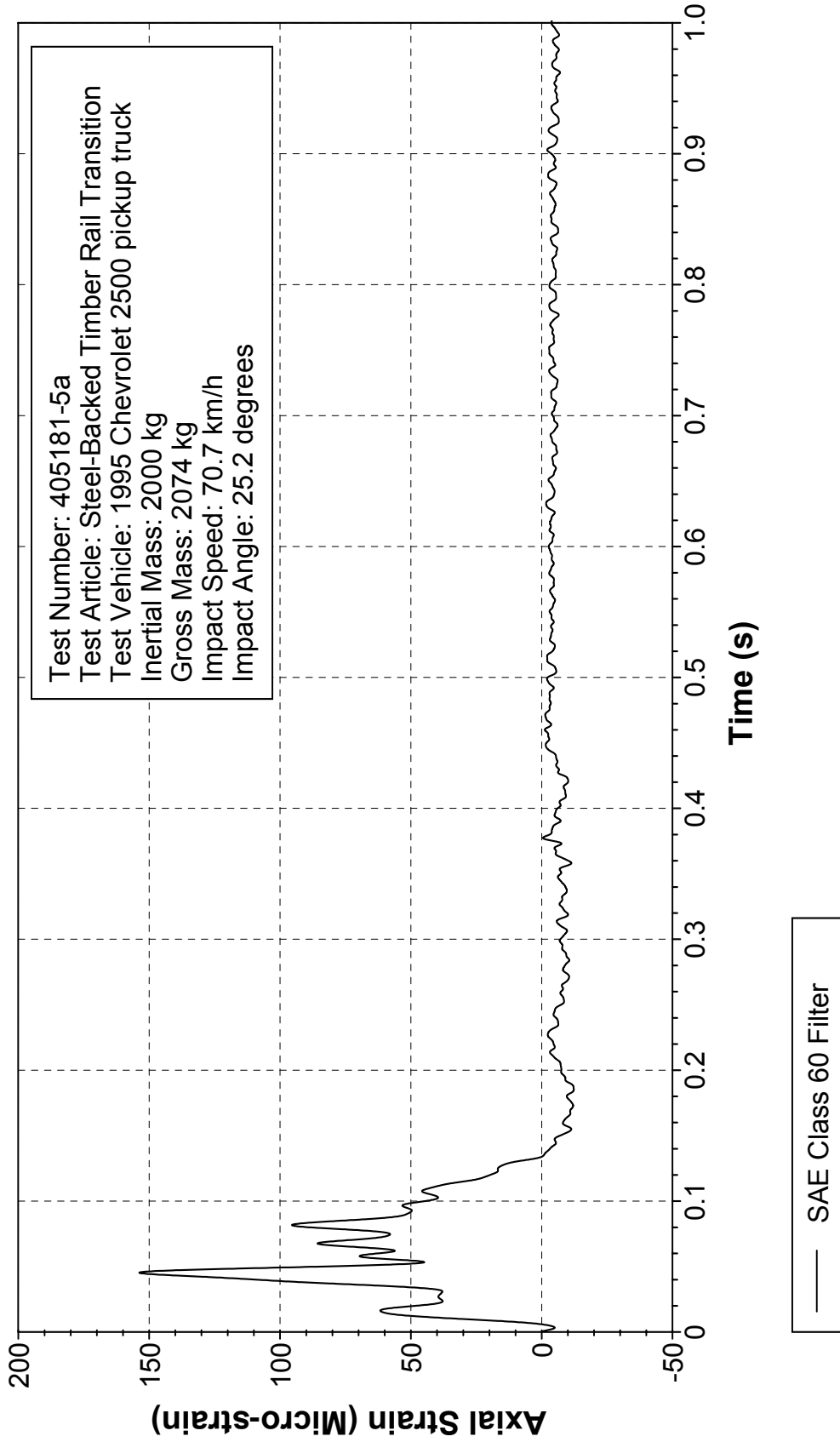

Figure 365. Axial strain, location 4, field side for test 405181-5a.

# Gage Location 5

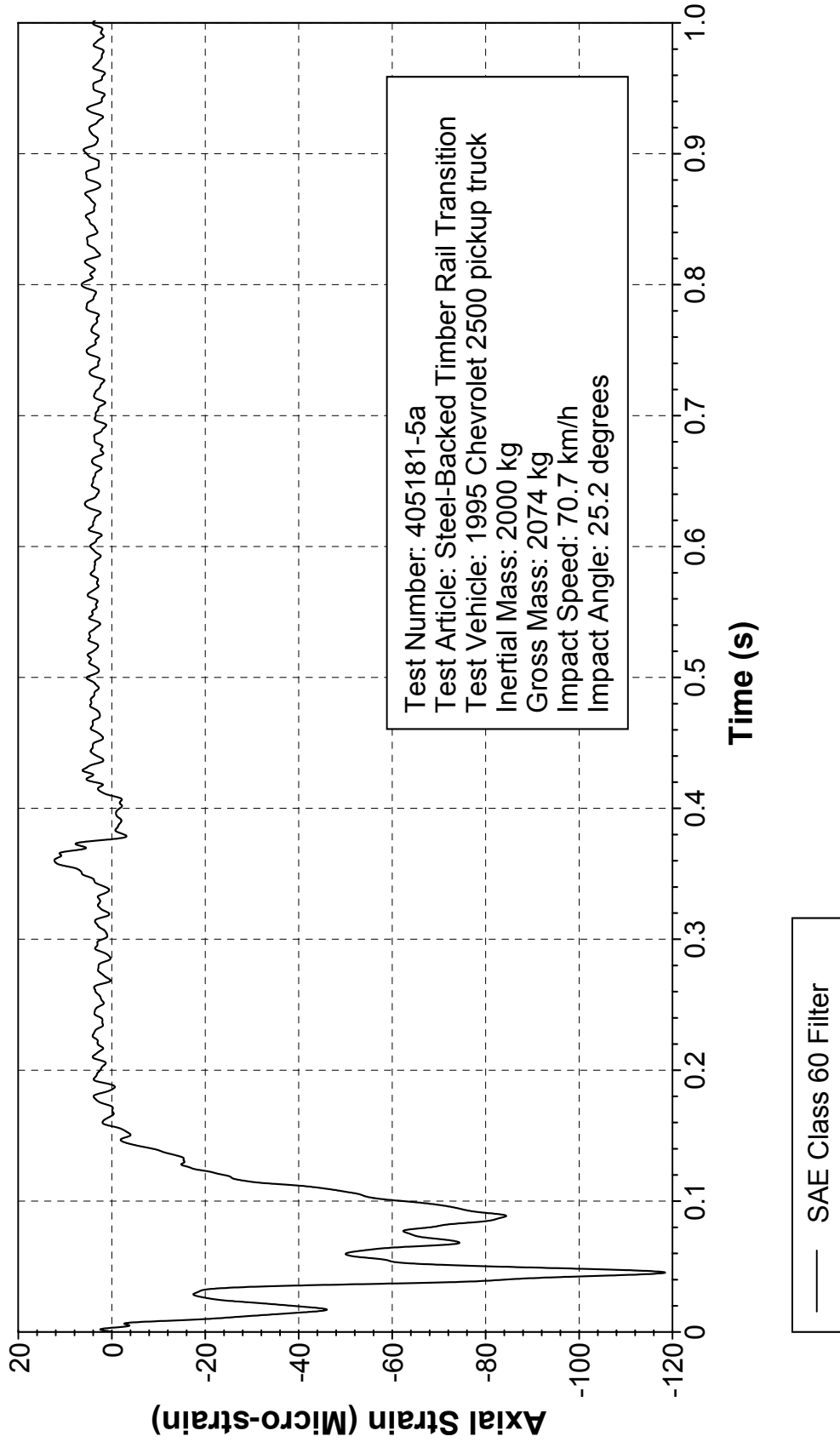

Figure 366. Axial strain, location 5, field side for test 405181-5a.

# Gage Location 6

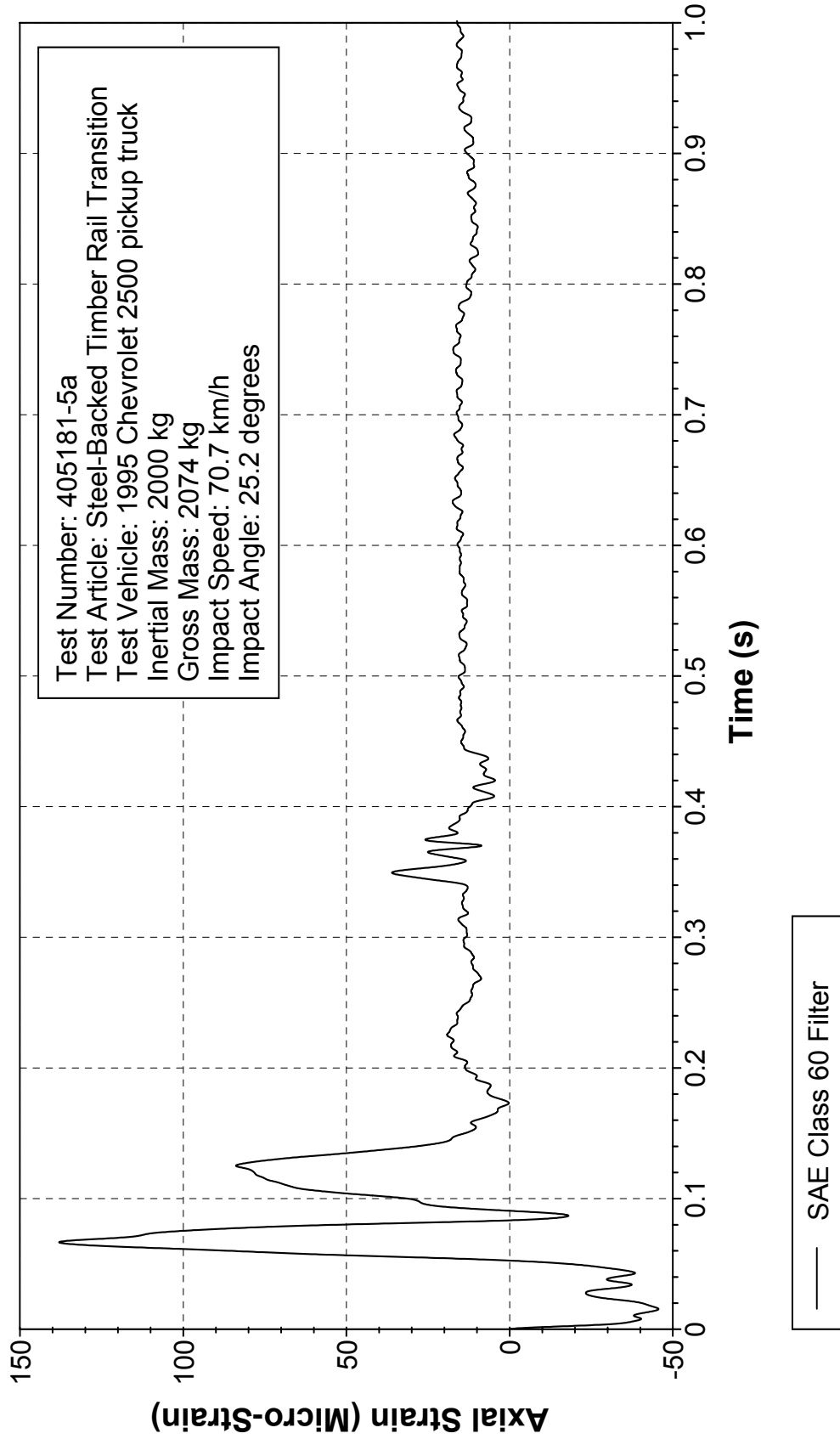

Figure 367. Axial strain, location 6, field side for test 405181-5a.